



Interconnection Facilities Study Final Report

Request # GI-2003-1

**300 MW Wind Farm Located Near Akron, Colorado
Interconnecting at Pawnee Station**

April 2005

Xcel Energy Services, Inc.
Transmission Planning – Denver, CO

I. Executive Summary

This Interconnection Facilities Study Report summarizes the analysis performed by Public Service Company of Colorado (PSCo) to specify and estimate the cost of the equipment, engineering, procurement, and construction needed to interconnect 300 MW of new generation at the Pawnee Station in Morgan County, Colorado. The new wind farm would be located just North of Akron, Colorado and would interconnect at Pawnee station via the Customer's 25 mile 230 kV transmission line. The requested commercial in-service date is October 24, 2005. However, the results of this study indicate that it is not feasible to implement the upgrades required to accommodate the project on a firm basis by the requested date.

The recommended Network Upgrades for Interconnection at Pawnee Station include a 230 kV circuit breaker, associated switches, metering, and transmission line rearrangement. with an estimated cost of \$730,000. The time frame to get the interconnection constructed for the generation addition would be approximately 9 months.

The total estimated cost for the facilities required for interconnection is approximately **\$0.735 million**¹ including:

- \$0.325 million for Customer-funded Interconnection Facilities (Table 1)
- \$0.410 million for PSCo Network Upgrades for Interconnection (Table 2)

The estimated time required to engineer, permit, and construct the facilities described above is at least **9 months**.

The Network Upgrades recommended for full delivery of the generation consist of the following:

- Between Pawnee Station and Smoky Hill Substation, uprate the existing 230 kV line from 500 MVA to 800 MVA by using phase raisers to raise 15 transmission structures.
- From Pawnee Station to Ft. Lupton Station rebuild the existing 64 mile 230 kV 413 MVA rated line to a double circuit 230 kV, 800 MVA per circuit configuration.
- Uprate the existing 230 kV line from Story to Pawnee Station from 576 MVA to 650 MVA by adjusting the rating methodology for that line to allow for a higher conductor temperature.
- Uprate the existing 230 kV line from Ft. Lupton Station to Henry Lake Substation to Riverdale Substation to Cherokee Station from 435 MVA to 475 MVA. This can be accomplished by replacing transmission line and equipment jumpers at Riverdale and Cherokee.
- The 230 kV main buses at Cherokee must also be replaced with 5-inch aluminum bus tube from the existing 1272 kCMIL ACSR.

The System Impact Study Report estimated the cost of these additional upgrades to be **\$45.79 million**² (Table 3). The estimated time required to engineer, permit, and

¹ Appropriation estimate considered to have an accuracy of +/- 20%.

construct the facilities for delivery is a minimum of **36 months** from the date a Transmission Service Agreement is executed. Therefore, it is not feasible to implement the facilities required to accommodate the project on a firm basis by the proposed in-service date.

The total estimated project cost for the PSCo facilities required for interconnection and delivery is approximately **\$46.5 million**.

A proposed Station One-Line diagram for the Pawnee Switchyard is shown in Figure 1. Figure 2 shows the proposed Network Upgrades associated with Delivery for this transmission project.

² Scoping, or planning level estimate considered to have an accuracy of +/- 30%.

Figure 1 Pawnee Switchyard: Proposed Substation One-Line Diagram

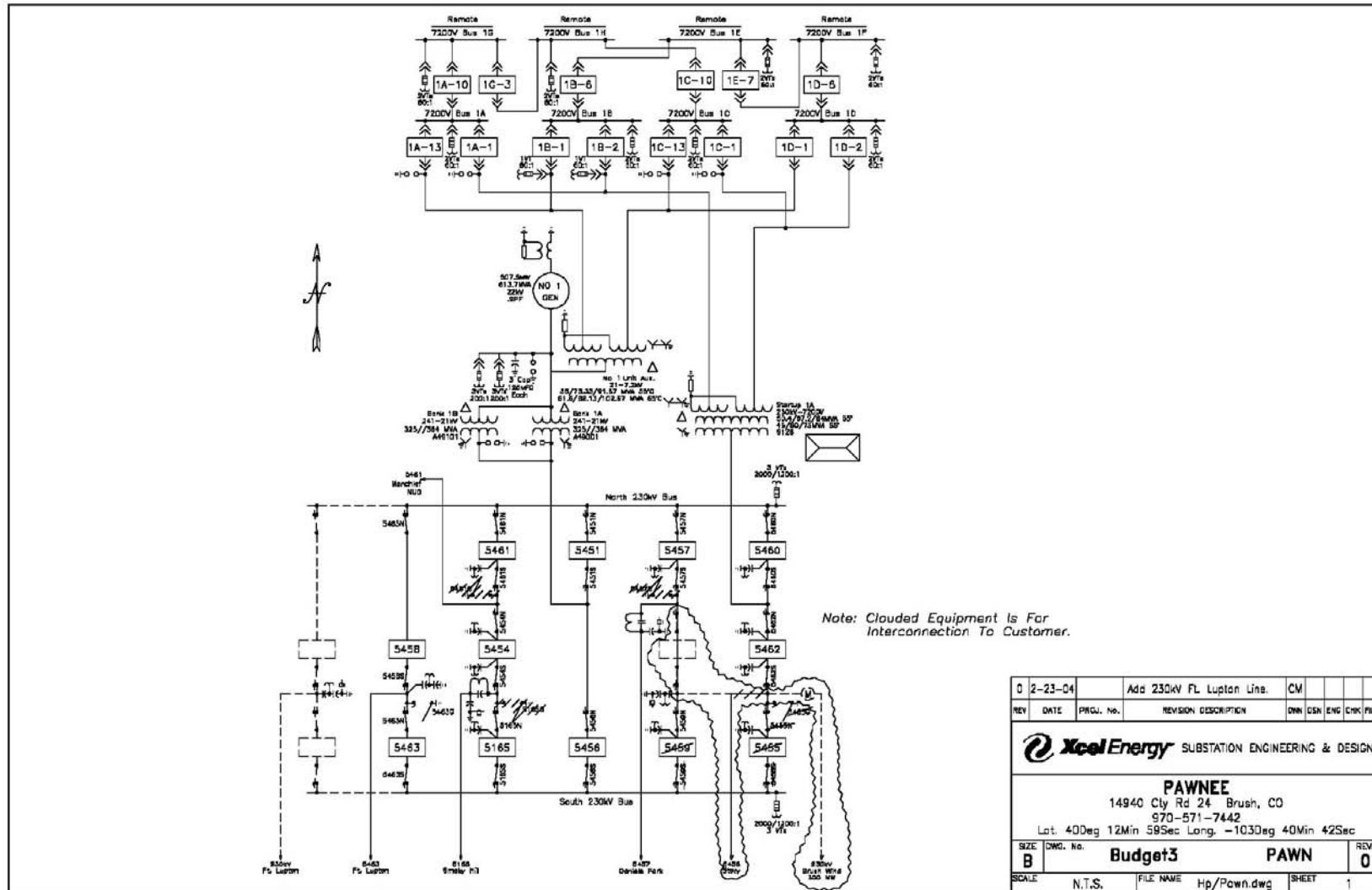

Figure 2

II. Introduction

On October 21, 2003 Xcel Energy Transmission received a request to conduct a feasibility study that would evaluate the integration of a 300 MW wind power generating facility in Morgan County, Colorado. The Feasibility Study report was issued and posted on the Rocky Mountain Area OASIS (RMAO) web site³ in March 2004. An Interconnection System Impact Study (SIS) Agreement was executed with the Customer on or around April 21, 2004, with the SIS Final report posted on RMAO and issued to the Customer on October 3, 2004. An Interconnection Facilities Study Agreement was executed with the Customer on November 18, 2004.

III. General Description (Project Design Guide)

Project Purpose & Scope

The purpose of this project is to interconnect a customer's wind generation of approximately 300 MW into PSCo's existing Pawnee 230 kV Substation. The customer proposes to build a 25 mile 230 kV transmission line from their site to the substation. The customer's proposed site is due east of Pawnee substation. The additional equipment at Pawnee due to the customer's new transmission line will have little effect on the size of the switchyard. The new transmission line to the customer's wind site will terminate into an existing bay that will be vacated by swinging an existing transmission line over one bay to accommodate the new transmission line. See the attached Preliminary 1-line drawing and general arrangement for the substation additions.

Background

Pawnee substation is a 5 bay breaker and half transmission switching station, which sits adjacent to the Pawnee Generating Station. Presently the Pawnee Generating Station injects approximately 500 MW into Pawnee substation. The additional injection of 300 MW into Pawnee from the customer's wind site requires upgrading and/or replacing various facilities throughout Xcel Energy's Denver Metro region.

Other Considerations

The desired back feed date for the customer is October of 2005. However equipment lead times are 6 to 9 months and work for the project cannot begin until an Interconnection Agreement has been executed. Special agreements should be made to meet a fourth quarter 2005 back feed date.

³ www.rmao.com

A. Interconnection & Network Upgrades for Interconnection

Fault Current

Existing 3 phase and SLG fault currents are 19,321A and 22,233A respectively at the Pawnee 230 kV bus.

Physical - Electrical Installations

The installation at Pawnee substation will consist of adding one 230 kV SF6 circuit breaker, two 230 kV gang switches, one line CCVT, three 230 kV combo CT/PT metering units, metering, and various structures will be installed to accommodate the customer's interconnection

The customer shall be required to install a 230 kV circuit breaker on the customer's end of the 25-mile transmission line to meet the PSCo/Xcel Energy interconnection guidelines.

The customer's step-up transformer(s) shall be designed to meet PSCo's interconnection guidelines. The configuration shall be GROUNDED - WYE on the 230 kV side, WYE on the 34.5 kV side, and DELTA on the tertiary. This will ensure that the customer meets PSCo's requirements for an effectively grounded system.

AC & DC Systems

Existing AC and DC panels are adequate for new substation equipment.

Control Building

All new equipment will fit into existing building.

Grounding

All equipment and associated structures will be connected to the ground mat.

Lightning Protection

The static wires on the transmission lines will be connected to the dead-end structures within the substation to provide overhead direct stroke protection.

Grading & Fencing

No grading or fencing is required as all new equipment is going into existing bays.

Foundations & Structural

Circuit Breaker, metering units, and CCVT foundations will be new. Structures for gang switches are existing bus supports and will be reused.

Removals & Relocations

The 230 kV Pawnee to Story transmission line will be relocated one bay west to accommodate the new transmission line from the customer.

Control & Protection - Electrical Installations

A new relay panel will be installed in the control building. Line protection will consist of a primary relay with pilot communication over fiber in a differential scheme with step distance protection elements utilized as a backup feature, a secondary relay also using fiber in a blocking scheme with step distance protection elements used as a backup feature, and a breaker-failure relay. Since this is a radial line owned by the customer, no automatic reclosing will be utilized. Transmission line relay settings and coordination will be performed in conjunction with the customer. Transmission line relay design by the customer shall be subject to review by PSCo.

Additional interconnection requirements will need to be satisfied as stated in PSCo's Interconnection Guidelines For Transmission Interconnected Producer-Owned Generation Greater Than 20.

The existing RTU at Pawnee will handle the additional SCADA information for the new transmission line and generating facility.

Outages

The existing Pawnee to Story 230 kV line will be out of service during the line swing period. This cutover period shall be minimized as much as possible.

Project and Operating Concerns

Work will be performed inside an energized 230 kV substation.

Related Substation & Transmission Projects

See Network Upgrades for Delivery.

Assumptions for Brush Wind

Customer will provide power factor correction equipment to meet voltage tolerances at point of interconnection, if needed.

Customer will engineer, procure, and construct all equipment up to the Pawnee 230 kV dead-end structure. This includes transmission line relay equipment at customer's site.

The customer will need to arrange for station service power through the local utility/service provider, as customer's site may not be in PSCo service territory.

Customer will build transmission line with fiber optic ground wire built into the static wire for relay communication.

PSCo needs approximately 2-4 weeks to test requirements of Interconnection Guidelines For Transmission Interconnected Producer-Owned Generation Greater Than 20 MW. Much of the testing can be performed in parallel with the construction schedule.

Assumptions for Pawnee

PSCo meters will be 4 quadrant, bi-directional meters with recorders. Meters/recorders will be equipped such that they can be accessed remotely through a phone circuit.

PSCo will engineer, procure, construct, own, and maintain all 230 kV facilities associated with the substation expansion.

Equipment lead times will dictate the time needed to build facilities. Current lead times are 6 to 9 months.

B. Network Upgrades for Delivery

In general the network upgrades for delivery shall mean the additions, modifications, and upgrades to the transmission provider's transmission system (PSCo) required at or beyond the point at which the interconnection facilities connect to the transmission provider's transmission system to accommodate the interconnection of the large generating facility (customer) to the transmission provider's transmission system. See FERC 2003-A definitions for further explanation.

The following network upgrades required for delivery are:

- Between Pawnee Station and Smoky Hill Substation, uprate the existing 230 kV line from 500 MVA to 800 MVA by using phase raisers to raise 15 transmission structures.
- From Pawnee Station to Ft. Lupton Station rebuild the existing 64 mile 230 kV 413 MVA rated line to a double circuit 230 kV, 800 MVA per circuit configuration.
- Uprate the existing 230 kV line from Story to Pawnee Station from 576 MVA to 650 MVA by adjusting the rating methodology for that line to allow for a higher conductor temperature.
- Uprate the existing 230 kV line from Ft. Lupton Station to Henry Lake Substation to Riverdale Substation to Cherokee Station from 435 MVA to 475 MVA. This can be

accomplished by replacing transmission line and equipment jumpers at Riverdale and Cherokee.

- The 230 kV main buses at Cherokee must also be replaced with 5-inch aluminum bus tube from the existing 1272 kCMIL ACSR

Assumptions

Contract for interconnection with customer has been executed and project is underway.

Timeframe to complete all of the necessary network upgrades for delivery is **substantially longer** than customer's requested in service date.

The construction of the network upgrades for delivery will have to be carefully planned. Not all of the work can be performed at the same time due to transmission capacity restraints.

Enough space will be available at Ft. Lupton substation to accommodate the substation expansion. If other projects planned for this location are constructed ahead of this project, then this assumption may no longer be valid.

PSCo will engineer, procure, construct, own, and maintain all facilities associated with the network upgrades for delivery.

IV. Costs Estimates and Assumptions:

A. Interconnection

The estimated non-binding good faith total cost for the PSCo Interconnection Facilities and Network Upgrades to provide an Interconnection for the Customer requested generation is:

- **\$ 0.325 million for Customer Interconnection Facilities at Pawnee Station (Customer funded).**
- **\$0. 410 million for PSCo Network Upgrades for Interconnection.**
- **Total Estimated cost of Interconnection = \$0.735 million**

The estimated costs shown above are "appropriation estimates" with an accuracy of \pm 20%. These estimates do not include any costs for any Customer-owned, supplied, and installed equipment and associated design and engineering for the Customer's facilities. Detailed appropriation level estimates were not performed for estimating the Network Upgrades for Delivery; these upgrades are discussed later, with only scoping level estimates repeated here as performed for the earlier System Impact Study.

B. Stand-Alone

"Stand Alone Network Upgrades" are defined by the FERC LGIP as Network Upgrades that the Interconnection Customer may construct without affecting the day-to-day

operations of the Transmission System during their construction. The Transmission Provider and Interconnection Customer must agree as to what constitutes Stand Alone Network Upgrades and identify them in Appendix A to the Standard Large Generator Interconnection Agreement.

For this generation interconnection request, it is assumed that there are not any Stand Alone Network Upgrades.

C. Delivery

The additional costs for PSCo Transmission Network Upgrades for Delivery of the full new generation output to PSCo native loads were estimated during the System Impact Study at:

- **\$ 45.79 million⁴ for additional PSCo Transmission Network Upgrades for Delivery**

Therefore, the total estimated project cost for the PSCo facilities required for interconnection and delivery is approximately **\$46.5 million**.

The Project Design Guide included in Part III of this report describes the assumptions and additional details associated with this project. The cost responsibilities associated with these facilities shall be handled as per current FERC guidelines.

D. Interconnection Facilities Component Costs Estimates and Assumptions:

Table 1 describes the improvements assumed necessary to be performed by PSCo Transmission, as dedicated “sole-use” facilities at PSCo Pawnee Station Substation for the new Customer interconnection. It does not include all of the costs associated with Network Upgrades, required at or beyond the Point of Interconnection (POI) to the PSCo transmission system, and delivery (NR) of the generation. Those costs are identified in Tables 2 and 3. It is assumed that all of the Customer owned, supplied, and operated equipment, both installed at PSCo Pawnee Station Substation, and equipment installed between and at the Customer generation site, will be designed, and installed by the Customer, or its contractors. (Such as the Customer’s 230 kV transmission line from their site to Pawnee and other associated Customer–owned substation / plant equipment). The costs of these Customer owned / operated facilities have not been estimated for by PSCo Transmission. The General Arrangement drawing for the Pawnee switchyard is shown in Figure 5.

Table 1: PSCo Transmission Interconnection Facilities (Customer funded):

Substation	Description	Cost (\$Million)
------------	-------------	------------------

⁴ Scoping, or planning level estimate considered to have an accuracy of +/- 30%.

Substation	Description	Cost (\$Million)
PSCo Pawnee Generation Station	Interconnect Customer’s 230kV line, which will require the relocation of the existing Pawnee to Story 230kV line to one bay west to allow the new Customer owned line to terminate in this position. The new equipment required includes: <ul style="list-style-type: none"> • 230kV bi-directional revenue metering; • supporting cable, foundations and structures; • associated control and relaying changes, additions and testing 	\$.260
Transmission	Construct new tie-line into plant substation	\$.045
Siting and Permitting	Siting and Land Rights activities for required easements, reports, permits and licenses	\$.020
	Total Cost Estimate for Interconnection Facilities	\$.325

Table 2 describes the costs associated with providing an interconnection to PSCo Transmission’s system. It does not include all of the costs required for full delivery of the generation. Those costs are included in Table 3.

Table 2 PSCo Transmission Network Upgrades Required for Interconnection:

Location	Description	Cost (millions)
PSCo Pawnee Generating Station	Upgrade/expand the existing 230KV transmission plant substation to accommodate the relocation of the existing Pawnee to Story 230kV line to one bay west to allow the new Customer owned line to terminate in this position. The new equipment required includes: <ul style="list-style-type: none"> • one 230KV, 3000 amp gas breakers; • two 230KV, 3000 amp gang switches; • one 230KV CCVT transformer; • associated communication upgrades, transmission line and bus relaying and testing; • supporting station wiring, cable, foundations and structures 	\$.410

Location	Description	Cost (millions)
	Total PSCo Network Upgrades Required for Interconnection	\$.410
Time Frame		9 Months (Back-feed)

E. Delivery Component Costs Estimates and Assumptions

Table 3 describes the estimated “scoping level” (+/- 30%) costs of PSCo Network Upgrades for Delivery, those associated with firm delivery of the 300 MW generation to PSCo Transmission native load. These costs were first determined during the System Impact Study, and have not been significantly refined for this Facilities Study. More detailed, and higher accuracy estimates will need to be performed at later stages in this project, due to the high level of uncertainty regarding specific line routes, permitting, and other details typical for transmission line design and construction of this nature. Many of these details will be determined during the Certificate of Public Convenience and Necessity (CPCN) to be filed with the Colorado PUC for this project.

Table 3 PSCo Transmission Network Upgrades Required for Delivery

Location	Description	Cost (millions)
Pawnee Station	New 230KV double circuit line termination and additional bay to Ft. Lupton. The new equipment required includes: <ul style="list-style-type: none"> • two 230KV, 3000 amp gas circuit breakers; • fourteen 230KV, 3000 amp gang switches; • supporting station wiring, cable, foundations and structures; • associated communication upgrades, transmission line and bus relaying and testing 	\$1.290

Location	Description	Cost (millions)
Ft. Lupton Station	<p>New 230KV double circuit line termination and additional bay to Ft. Lupton - which will require rearranging of the existing line terminations for the Henry Lake and Green Valley lines. The new equipment required includes:</p> <ul style="list-style-type: none"> • three 230KV, 3000 amp gas circuit breakers; • ten 230KV, 3000 amp gang switches; • supporting station wiring, cable, foundations and structures; • associated communication upgrades, transmission line and bus relaying and testing 	\$1.280
Smoky Hill Substation	<p>Upgrade existing facilities on the Pawnee 230KV line termination. The new equipment required includes:</p> <ul style="list-style-type: none"> • two 230KV, 3000 amp gas circuit breakers; • four 230KV, 3000 amp gang switches; • supporting bus, insulators, station wiring, cable, foundations and structures • required communication upgrades (2000 amp line trap) 	\$.960
Riverdale	Upgrade conductor on the line side of the line-rupters and gang switches to double 1272 aluminum	\$.055
Quincy Substation	Replace existing 1200 Amp line-rupters with 2000 Amp line-rupters	\$.290
Cherokee	<p>Increase existing line capacity to higher M230KVA rating. The new equipment required includes:</p> <ul style="list-style-type: none"> • one 230KV, 3000 amp gas circuit breakers; • supporting bus, insulators, station 	\$.650

Location	Description	Cost (millions)
	wiring, cable, foundations and structures	
Transmission	Rebuild existing 413 MVA 230kV line from Pawnee to Ft. Lupton with new double circuit 230kV 834 MVA transmission utilizing existing ROW as much as possible	\$40.215
	Uprate the existing Pawnee to Quincy/Smoky Hill 230KV Line to 800 MVA from 500 MVA by installing approximately 15 phase raisers.	\$.220
	Uprate Ft. Lupton to Henry Lake to Riverdale to Cherokee 230kV line from 435 MVA to 475 MVA. Need an aerial survey to determine current ground clearances.	\$.230
	Uprate Story to Pawnee 230kV line from 576 MVA to 650 MVA	\$0
Siting and Permitting	Siting and Land Rights activities for required easements, reports, permits and licenses	\$.600
	Total Cost Estimate for PSCo Network Upgrades Required for Power Delivery	\$45.790
Time Frame		36 Months

Total costs for Network Upgrades for Interconnection and Delivery Costs = **\$46,525,000**

Assumptions:

1. The estimated costs provided for Interconnection costs are “Appropriation Estimates” with an accuracy of $\pm 20\%$. The estimated costs provided for Delivery/Infrastructure upgrade costs are “Scoping Estimates” with an accuracy of $\pm 30\%$.
2. All applicable overheads are included. AFUDC has been removed.
3. Estimates were escalated at 3% per year through 2005.
4. PSCo (or its contractor) crews will perform all construction and wiring associated with PSCo-owned and maintained equipment.
5. A Certificate for Convenience and Public Necessity (CCPN) will be required for the transmission line.
6. Any NEPA requirements imposed on transmission because of the generation addition will most likely have adverse effects on schedule and deliverables.
7. No screening has been estimated at any of the substations. If this is required the cost will be significant at each location.

8. Detailed field investigations (surveys, etc.) have not been conducted and could increase these estimates.
9. Approximately 5 miles of new transmission line ROW acquisition is assumed for Network Delivery related facilities, since existing ROW will be utilized. The Customer Interconnection requires new ROW.
10. These estimates do not include any cost for legal fees.
11. All necessary transmission line outages can be obtained. If not, construction duration times will be longer.
12. All cost estimates have been escalated to reflect the appropriate year of project activity.

The overall timeline to complete all required transmission and substation facilities is expected to require a minimum of 36 months. If there are problems with local and state approvals, this could require an additional year.

V. Engineering, Procurement & Construction Schedule

The following schedule identifies milestones needed to complete the interconnection of the proposed 300 MW wind farm.

Figure 4: Engineering, Procurement & Construction Schedule

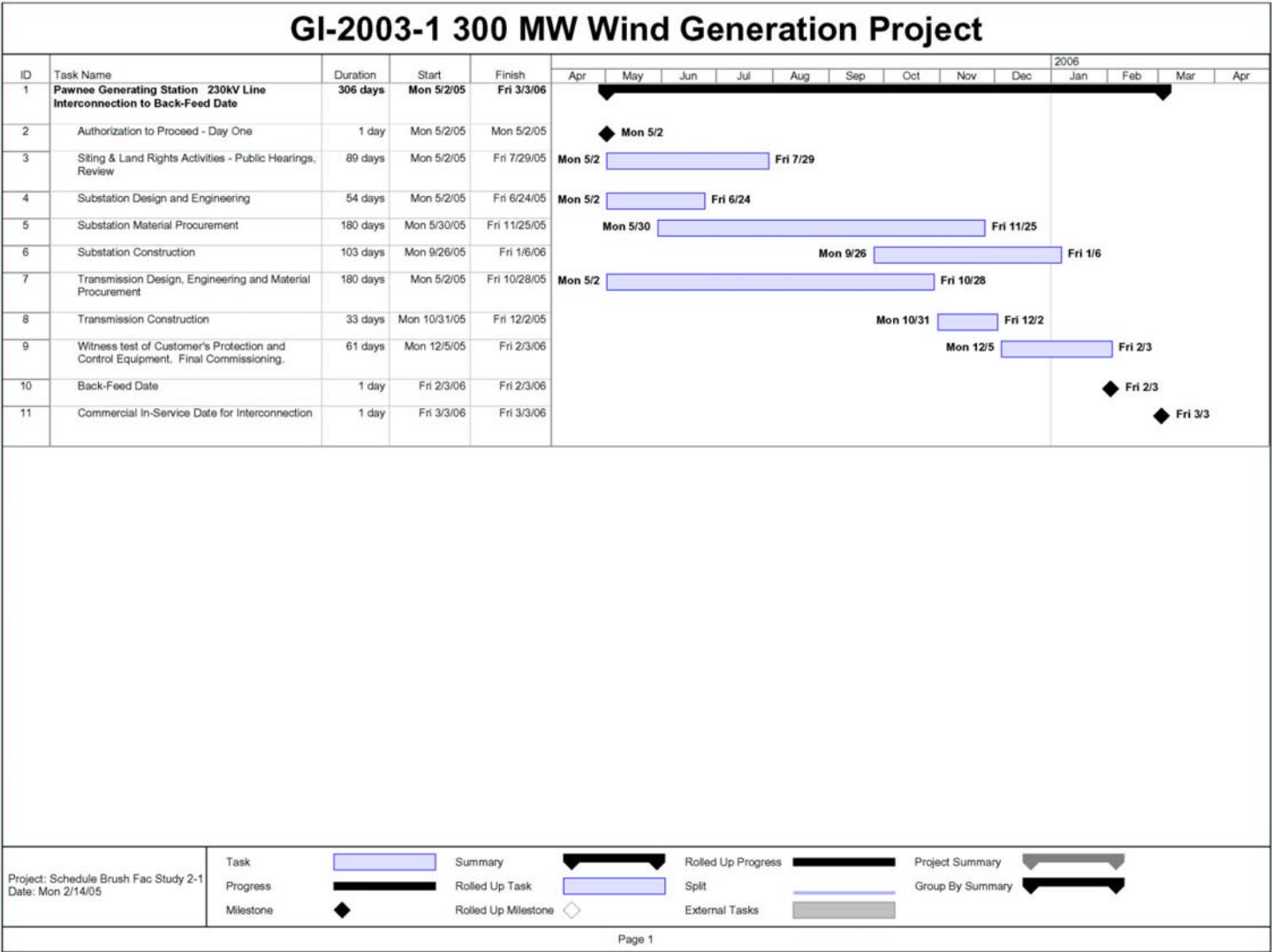

Figure 5: Pawnee Switchyard: Proposed General Arrangement Drawing

