



# **Draft Interconnection Facility Study Report**

## **Request # GI-2003-4**

30 MW Wind Generation Test Facility at Ponnequin

January 2005

Xcel Energy Services, Inc.  
Transmission Planning – Denver, CO

## I. Executive Summary

This Interconnection Facilities Study Report summarizes the analysis performed by Public Service Company of Colorado (PSCo) to specify and estimate the cost of the equipment, engineering, procurement, and construction needed to interconnect a new wind turbine generator test facility. The facility would be sited just north of the Colorado – Wyoming border, and would tie into the PSCo Ponnequin Substation, located just south of this border. The Ponnequin substation connects into the Western Area Power Administration (Western) Cheyenne – Rockport 115kV transmission line. The maximum net output of this new Customer generation facility would be 30 MW. .

The total estimated cost<sup>1</sup> of the facilities required for interconnection is approximately **\$3.3 million**, including:

- \$ 290k for the Customer Interconnection Facilities (Table 1)
- \$ 3.042 million for the PSCo Network Upgrades for Interconnection (Table 2)

Figure 1 depicts the regional transmission system. A proposed Station One-Line diagram for the PSCo Ponnequin Substation is shown in Figure 2. The estimated time frame to implement all facilities for interconnection and Commercial Operation is approximately ten months, corresponding to an estimated in-service date (ISD) of November 1, 2005. The proposed schedule estimates that back-feed power would be available one month prior to the commercial ISD.

---

<sup>1</sup> Appropriation estimate considered having an accuracy of +/- 20%.

**Figure 1: Regional Transmission System One-Line**

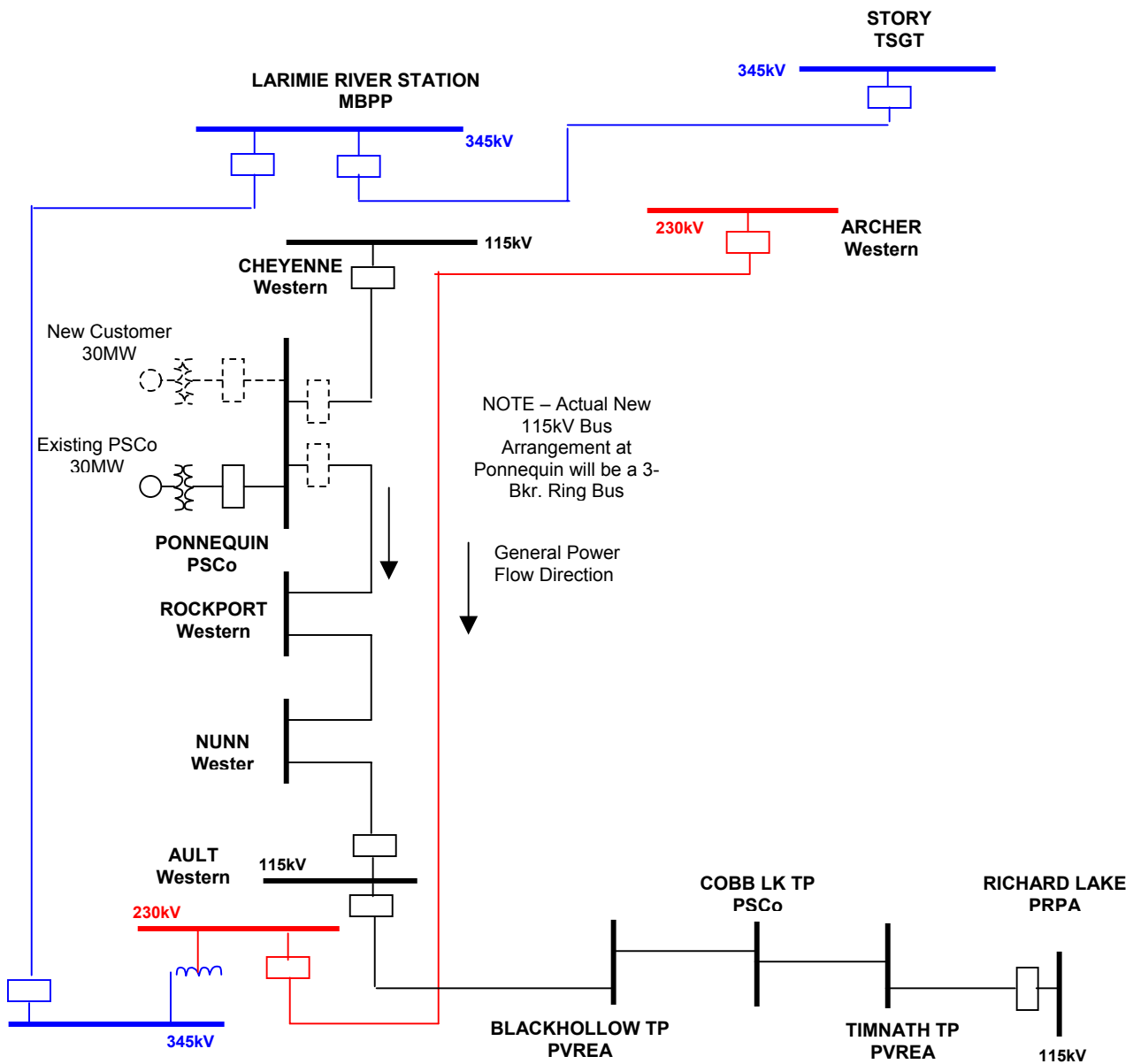

**Figure 2: Ponnequin Substation: Proposed One-Line Diagram**

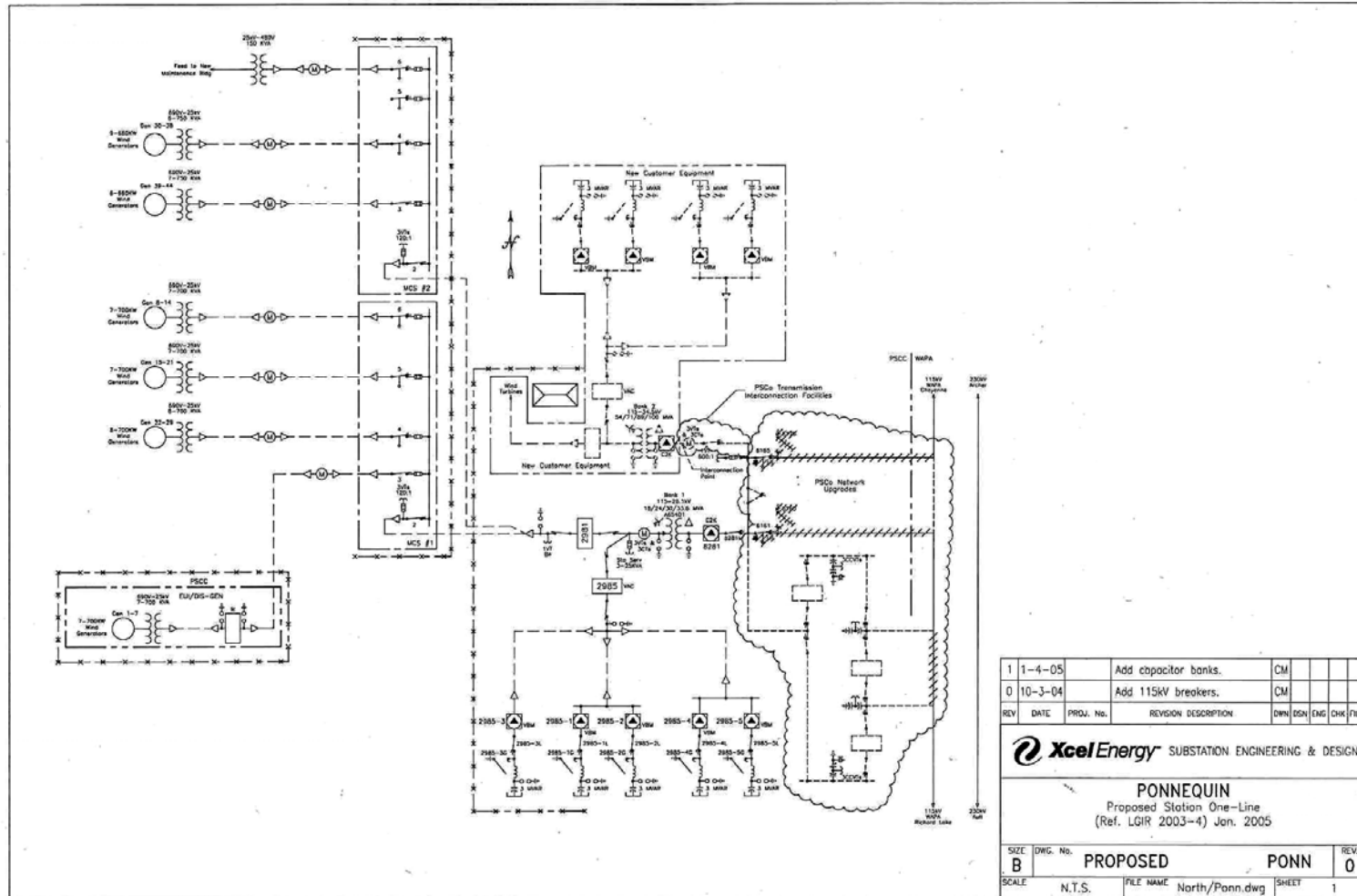

01/05/2005 02:13:17 PM

## II. Introduction

On November 11, 2003 Xcel Energy Transmission Planning received a request to interconnect a wind turbine generation test facility with a total installed net output capacity not to exceed 30 MW. PSCo completed an Interconnection Feasibility Study, and the report was issued and posted on the Rocky Mountain Area OASIS (RMAO) web site<sup>2</sup> in February 2004. An Interconnection System Impact Study (SIS) Agreement was executed with the Customer on or around March 15, 2004, with the SIS Final report posted on to the web site and issued to the Customer on July 30, 2004. An Interconnection Facilities Study Agreement was executed with the Customer on September 10, 2004. As an affected party, Western has participated in these efforts by providing review and comments to the reports, and additional system analyses.

The SIS indicated that the proposed facility could normally generate the full 30 MW into Ponnequin. However, studies performed by Western indicated that the full output of the Customer facility might, under certain conditions, impact the TOT 3 transfer limit. Western has indicated that in order to maintain reliable operation of their system for those particular conditions, an operational scheme may be required to reduce Customer generation at the Ponnequin facility. In addition, PSCo will develop protection schemes to prevent the facility from adversely affecting the regional transmission system.

## III. General Description (Project Design Guide)

### A. General Project Description:

The purpose of this project is to interconnect approximately 30 MW of wind generation to the existing Ponnequin 115kV Substation. Ponnequin Substation taps the existing Western Ault to Cheyenne 115kV transmission line. Interconnecting the new 30 MW facility into Ponnequin requires upgrading the existing facilities. The recommended upgrades include expanding Ponnequin from a tap substation to a breaker station. The design will be for a three-breaker ring-bus that will intersect the Western Ault to Cheyenne 115kV line, and tie in the wind generation transformer and associated Customer equipment.

### B. Background:

The existing Ponnequin site is a one-bank substation that connects 30 MW of PSCo wind generation to Western's Ault to Cheyenne 115kV transmission line. The Customer's new wind facility is going to be a wind generation certification test facility. The type and size of individual wind turbines will vary at any given time. The output of any combination of wind turbines from this test facility will not exceed 30 MW.

---

<sup>2</sup> www.rmao.com

### **C. Other Considerations**

The design of the 115kV three-breaker ring-bus allows for expansion to a breaker and a half configuration with one additional line termination. Western has mentioned the possibility of upgrading the transmission line to 230kV in the future. Therefore, the substation expansion will be designed and built to 230kV design standards. The phase spacing, insulators, and gang switches will be built for 230kV operation. However the breakers and metering units will be 115kV rated equipment. The Customer-supplied design for their facilities (electrical, physical, protection and control) will be reviewed by PSCo and Western to ensure that they meet the generation interconnection guidelines of both parties. Furthermore, the commissioning checkout of the new facilities will be witnessed by PSCo and Western personnel.

### **D. Physical Features (Ponnequin Substation):**

#### **1. Additional Removals & Installations**

The existing 115kV load-break switches will be removed from SCADA control, however they will not be physically removed from the substation.

#### **2. Fault Current**

Existing (2004) maximum symmetrical 3-phase and SLG fault currents are 5,860A and 4,044A respectively at the Ponnequin 115kV bus, assuming insignificant fault current contributions for the Customer's wind turbine generators.

#### **3. Electrical Installations**

The installation will consist of two breaker and a half bays with a total of three 115kV SF6 circuit breakers, eight 230kV gang switches, two sets of bus potentials, two line CCVT's, three dead-ends, bus supports, and various structures. It will operate initially as a three-position ring-bus. In the existing yard a 115kV bus tie switch, 115kV gang switch, 115kV combo CT/VT metering units, dead-end, new control building, and metering will be installed to accommodate the Customer's interconnection. A power quality monitor will be installed by PSCo to monitor the voltage and current associated with the 115kV main bus and Customer tap at Ponnequin.

The Customer's main transformer shall be designed to meet Western's interconnection guidelines. The winding configuration shall be delta on the 115kV side and grounded-WYE on the 34.5kV side to limit fault current contribution to Western's transmission system. The transformer design is subject to review by Western and PSCo. The Customer is also responsible for

the high-side 115kV interrupting device of the transformer (e.g., breaker or Circuit Switcher). This device is also subject to review by Western and PSCo.

4. Control Building

The existing Electrical Equipment Enclosure (EEE, control building) is not large enough to house the additional equipment required for the substation expansion. A new EEE, approximately 15 ft. x 30 ft., will be installed primarily to contain the additional protection, metering, and control devices for PSCo and Western. The EEE will be designed with enough extra space to house the Customer's DC battery system, transformer protection & controls, capacitor bank controls, and any other termination equipment necessary. All of the Customer's proposed equipment for the EEE will be subject to review by Western and PSCo.

5. Lightning Protection

The static wires on the transmission lines will be connected to the dead-end structures within the substation to provide overhead direct stroke protection.

6. AC & DC Systems

Existing station service power will continue to power the existing and new PSCo/Western substation equipment. The only change required will be to upgrade the size of the substation battery and charger to accommodate the increased DC load. The Customer will need to arrange for station service power through the local utility/service provider, as Ponnequin is not in PSCo's service territory.

7. Grounding

All equipment and associated structures will be connected to the ground mat.

**E. Civil Features (Ponnequin Substation):**

1. Grading & Fencing

Moderate grading is required. The complete civil engineering and design details have not been determined at this time.

2. Foundations & Structural

All foundations and structures are new.

3. Removals & Relocations

None required.

**F. Control Features (Ponnequin Substation):**

1. Electrical Installations

New relay panels will be installed in the EEE. Line protection for both lines will consist of a primary relay with pilot communication over microwave in a POTT scheme, a backup relay using step distance protection elements, and a combination breaker-failure/reclosing relay. The reclosing will be initiated by both primary and secondary relays and will be supervised by a sync check. Transmission line relay settings and coordination will be performed in conjunction with Western. Transmission line relay design will be coordinated between Western and PSCo.

Bus protection between the 115kV side of the step-up transformers and 115kV ring bus will be provided through a bus differential relay. The bus relay design is subject to approval by Western.

Transformer protection may consist of a primary current differential relay and an over-current relay for backup. The Customer will provide a detailed protection scheme for their transformer that will be subject to review by Western and PSCo.

Additional interconnection requirements will need to be satisfied as stated in PSCo's Interconnection Guidelines For Transmission Interconnected Producer-Owned Generation Greater Than 20 MW and Western's General Requirements for Interconnection.

The existing RTU at Ponnequin will be expanded to handle all of the additional substation equipment's control, status, analog, and alarm points. The RTU will continue to be dual-port for the Western control and status information. Western will have primary operational control of all 115kV circuit breakers, while PSCo will have only emergency control. PSCo will have primary control of the 's high-side transformer interrupting device. As stated previously the existing 115kV load-break switches will be removed from SCADA control.

## **G. Outages**

The existing Cheyenne – Ponnequin – Rockport sections of the Ault - Cheyenne 115kV line will be out of service during the cut over period. This cutover period shall be minimized as much as possible.

## **H. Project and Operating Concerns**

Work will be performed adjacent to energized 115kV and 230kV lines.

## **I. Related Substation & Transmission Projects**

Western will be modifying their existing 115kV transmission line relaying protection at Western's Cheyenne and Ault transmission substations. This relaying protection will



be modified to coordinate with the new line sectionalizing breakers required by Western at PSCO Ponnequin Substation.

#### **IV. Costs Estimates and Assumptions**

The estimated non-binding good faith total cost for the PSCO Interconnection Facilities and Network Upgrades to provide an Interconnection for the Customer requested generation at the PSCO Ponnequin Substation is:

- **PSCO Interconnection Facilities = \$ 290k**
- **PSCO Network Upgrades for Interconnection = \$ 3.042 million**
- **Total Estimated cost of project: \$ 3.332 million**

The estimated cost shown is an “appropriation” (+/-20%) budgetary cost in 2005 dollars, includes escalation, and is based upon typical construction costs for previously performed similar construction. These estimated costs include all applicable labor and overheads associated with the engineering, design, and construction of these new PSCO facilities. This estimate does not include any costs for any Customer-owned, supplied, and installed equipment and associated design and engineering. This estimate also does not include any costs that may be required for other entities.

The Project Design Guide included previously in this Report as Item III, and Basic Project Schedule included as following Item V, describe the details and assumptions used for estimating the PSCO portion of the Interconnection Facilities and Network Upgrades for Interconnection that would be required for both ER and NR requests. The cost responsibilities associated with these facilities shall be handled as per current FERC guidelines.

##### **A. Interconnection Facilities: Component Costs Estimates**

Table 1 describes the dedicated “sole-use” facilities improvements assumed necessary to be performed by PSCO for the new Customer interconnection. The cost responsibilities are not addressed in this Report, but and will be covered in the Large Generator Interconnection Agreement (LGIA). Table 2 describes the costs associated with Network Upgrades required at or beyond the Point of Interconnection (POI) to the transmission system. It is assumed that all of the Customer-owned, supplied, and operated equipment, both installed at Ponnequin Substation, and equipment installed between and at the Customer Wind TG Test facility site, will be designed, and installed by the Customer, or its contractors (such as the main 115 – 34.5kV transformer, 115kV fault interrupter, 34.5kV capacitor banks, and other associated Customer-owned substation equipment). PSCO has not estimated for the costs of those Customer facilities.

<b>Table 1: Customer Interconnection Facilities</b>		
<b>Location</b>	<b>Description</b>	<b>Cost (millions)</b>
PSCo Ponnequin Substation	Interconnect Customer's main 115-34.5kV transformer to the 115kV substation bus. The new equipment required includes: <ul style="list-style-type: none"> <li>• three 115kV CT/VT combination bi-directional metering units, including meter and recorder;</li> <li>• supporting cable, foundations and structures;</li> <li>• power quality monitor.</li> </ul>	\$ 0.290
<b>Total Cost Estimate for Interconnection Facilities</b>		<b>\$ 0.290</b>

Table 2 lists the costs associated with developing the transmission system in order to deliver the full 30MW of Customer generation into the PSCo and Western transmission systems at Ponnequin.

<b>Table 2: PSCo Network Upgrades Required for Interconnection</b>		
<b>Location</b>	<b>Description</b>	<b>Cost (millions)</b>
PSCo Ponnequin Substation	Upgrade/expand the existing 115kV substation from a tap substation to a breaker station (three breaker ring bus). Design and build to 230kV standards for future upgrades and expansion for a breaker and a half scheme. The new equipment required includes: <ul style="list-style-type: none"> <li>• three 115kV, 2000 amp gas breakers;</li> <li>• eight 230kV, 2000 amp gang switches;</li> <li>• one 115kV, 2000 amp gang switch;</li> <li>• one 115kV, 1200 amp vee switch;</li> <li>• eight 115kV CCVT transformers;</li> <li>• new electric equipment enclosure (EEE, control bldg);</li> <li>• associated communication upgrades, transmission line and bus relaying and testing;</li> <li>• supporting bus, cable, foundations and structures;</li> <li>• miscellaneous building wiring, grounding and materials;</li> <li>• fence, earthwork and yard surfacing.</li> </ul>	\$ 2.601
Western Ault Substation	Transmission line relaying upgrades and testing.	\$ 0.029
Western Cheyenne	Transmission line relaying upgrades and testing.	\$ 0.029

<b>Table 2: PSCo Network Upgrades Required for Interconnection</b>		
<b>Location</b>	<b>Description</b>	<b>Cost (millions)</b>
Substation		
Transmission	Relocate and replace existing 115 kV dead-end transmission line structures located outside the Ponnequin Substation to 2-double circuit 230 kV steel dead-end structures. Designed for 1272 ACSR conductor.	\$ 0.321
Siting and Permitting	Siting and Land Rights for required easements, reports, permits and licenses.	\$ 0.062
	<b>Total cost estimate for PSCo Network Upgrades Required for Interconnection &amp;</b>	\$ 3.042
Time Frame		9 Months (Back-feed)

**B. Interconnection Facilities: Assumptions**

1. The estimated costs provided are “Appropriation Estimates” with an accuracy of  $\pm 20\%$ .
2. All applicable overheads are included. AFUDC has been removed.
3. Estimates were escalated at 3% through Fall 2005.
4. Back-feed 9 months after receiving authorization to proceed, which is anticipated to correspond to back-feed service available for commencing on-line commissioning testing on or about October 1, 2005.
5. Commercial operation (ISD) 1 month after back-feed, which is anticipated to correspond to commercial in-service on or about November 1, 2005.
6. A Certificate of Public Convenience and Necessity (CPCN) will not be required from the Colorado Public Utility Commission (CPUC) for the PSCo Network Upgrades for Interconnection.
7. Assume new land requirements for expansion will be granted at no charge by the Landowner. Any additional equipment provided by the Customer will fit into existing land parcel or will be separate from existing/new yard.
8. Permitting cost estimates include PSCo responsibility to amend the existing Special Review Permit with public hearings anticipated.

10. PSCo (or its Contractor) crews will perform all construction and wiring associated with PSCo-owned and maintained equipment. Western crews will perform all work at their Ault and Cheyenne Substations.
11. PSCo will design, engineer, procure, construct, own and maintain all high side 115 kV facilities associated with the substation expansion at Ponnequin. Substation design is subject to Western review and approval.
12. Western will have primary SCADA and/or local control of all 115 kV breakers. PSCo will only have emergency control of the 115 kV breakers.
13. Customer will design, engineer, procure and construct all Customer's equipment up to the 115 kV CT/VT metering units.
14. PSCo needs a minimum of one month to witness testing of Customer's protection and control equipment associated with interconnection. This to be done in accordance with PSCo and Western requirements of Interconnection Guidelines for Transmission Interconnected Producer-Owned Generation Greater Than 20 MW. A majority of the testing can be performed in parallel with the 9-month to back-feed schedule.
15. The estimated time for design, procurement and construction for the PSCo network upgrades required for the interconnection is at least nine months after authorization to proceed. This includes time for Western review.
16. All required transmission outages necessary to support construction will be obtained as needed.
17. Customer will provide power factor correction equipment to meet voltage tolerances at point of interconnection. The power factor correction equipment will be installed inside existing substation land parcel.
18. PSCo meters will be four quadrant, bi-directional meters with recorders. Meters and recorders will be equipped such that they can be accessed remotely through a phone circuit.
19. Additional microwave channels for transmission line primary pilot communications, SCADA and voice phone are readily available for PSCo's and Western's needs.
20. The Interconnection Customer will install its own protection scheme for its main 115-34.5 kV transformer, 34.5 kV switched capacitor banks, 34.5 kV collector, switchgear or breakers and any other equipment connected to the low voltage side of the transformers.

21. Controls and protection scheme details between the PSCo, Western and the Customer will be finalized in the Interconnection Agreement.

22. Transmission service needs to be requested separately from Western prior to energizing the Customer’s new generation facility.

### V. Engineering, Procurement and Construction Schedule

The schedule shown in Figure 3 identifies milestones for the work required to complete the interconnection of the proposed 30 MW Wind Generation Test Facility at Ponnequin Substation. The following is a brief description of the schedule:

Interconnect the Customer’s main 115-34.5 kV transformer to the Ponnequin 115 kV Substation bus. Upgrade and expand the existing Ponnequin 115 kV Substation from a tap substation to a three-breaker ring bus. Design and build to 230 kV standards for future upgrades and expansion for a breaker and a half scheme.

It is anticipated that the work associated with this interconnection can be completed within nine months after authorization to proceed has been obtained, in order to provide electrical back-feed required by the Interconnection Customer to complete its testing and commissioning for the main transformer. PSCo will continue with its

**Figure 3**

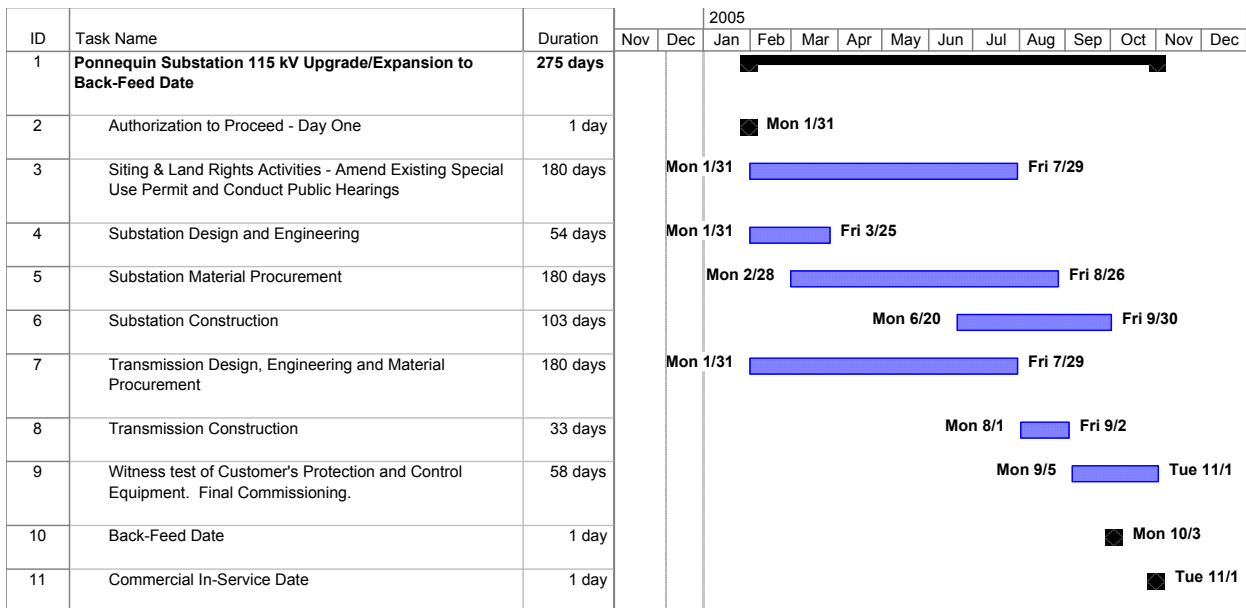

testing and commissioning work to support commercial operation of the main transformer, assumed to be approximately one month after back-feed.

**Figure 4: Ponnequin Substation: Proposed General Arrangement (Physical Layout)**

