



Interconnection Facilities Study Report Request # GI-2007-11

CTG #'s 5 & 6 (269 MW total - summer) Additions at Fort St. Vrain
Generation Plant in Summer 2009

PSCo Transmission Planning

December 11, 2008

I. Executive Summary

This Interconnection Facilities Study Report summarizes the analysis performed by Public Service Company of Colorado (PSCo) to specify and estimate the cost of the siting, engineering, equipment procurement and construction needed to interconnect 269 MW of new generation at the Fort St. Vrain Station in Weld County, Colorado. The new gas fired generation interconnects at the existing Fort St. Vrain Switchyard. The requested commercial in-service date is May 31, 2009.

The total estimated cost for the facilities required for interconnection is estimated at \$3.881 million¹ and includes two (2) 230kV IPO breakers, switches, bus work, metering, communications and transmission line bus tie connection.

- \$1.859 million for Customer-Funded Interconnection Facilities
- \$2.022 million for PSCo Network Upgrades for Interconnection
- The estimated time required to site, engineer, procure and construct the facilities described above is at least 9 months.

The recommended Network Upgrades for Delivery at Fort St. Vrain Switchyard are noted below. Total estimated costs are \$3.999 million. The estimated time frame to site, engineer, procure and construct the Network Upgrades for Delivery is at least 12 months.

Network Upgrades Required for Delivery:

- FSV: replace 15 additional 230kV breakers due to increased short-circuit interrupting duty requirements (completed in 2009 through June 2010, but do not impact 5/31/09 Commercial Operation Date).
- Replace the conductor on a 2.5-mile section of the Fort Lupton – FSV 230kV double circuit line.
- Minor line termination upgrades (conductor jumpers, relay settings changes, etc.) at Cherokee and Hogback Substations.
- Relocate the 50 MVAR Capacitor Banks (O&M expense)
- Expedite from May 2010 to May 2009 the previously approved and budgeted project to install a second 230/115kV, 280 MVA autotransformer at Valmont Substation.

Total Project Cost for Interconnection & Network Upgrades for Delivery: \$7.880 million (plus \$4.760 million separately budgeted, but expedited Valmont 230-115kV, 280 MVA autotransformer installation).

A proposed Station One-Line diagram for the Fort St. Vrain Switchyard is shown in Figure 1.

¹ Engineering estimates considered to have an accuracy of +/- 10%.

Figure 1: Fort St. Vrain Budget One-Line Diagram

(Note – additions for new GTG5 & GTG6 GSU's interconnection equipment shown dashed)

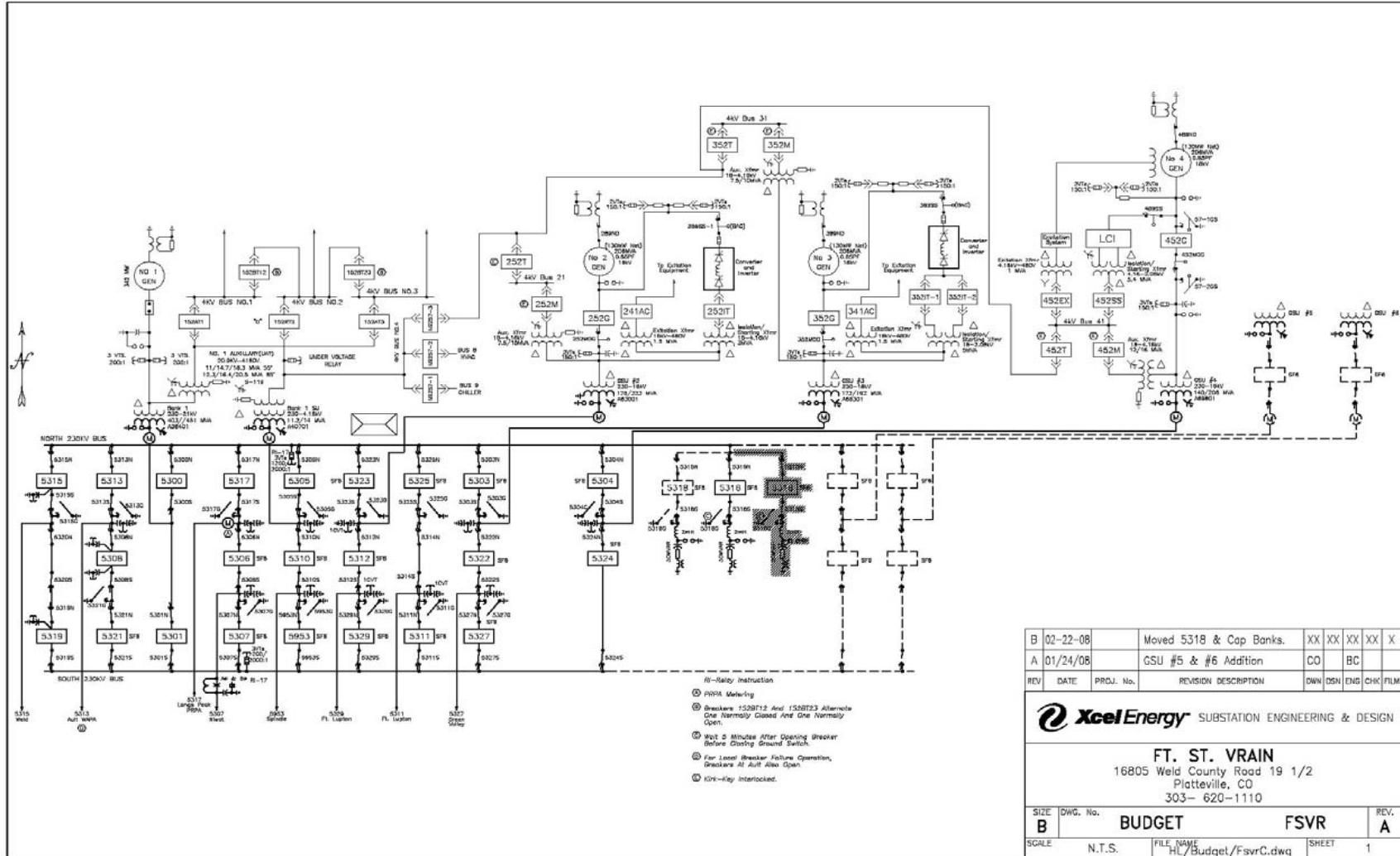



Introduction

On August 31, 2007 PSCo Transmission Planning received a request to conduct a special study that would evaluate the addition of 300 MW of gas fired generating facility in Weld County, Colorado. The results of the Non Queued study (NQ-2007-2) was issued and posted on the RMAO OASIS on October 24, 2007. On October 24, 2007 PSCo Transmission received an interconnection request to perform a System Impact study for the 269 MW of generation at Fort St. Vrain for the winter season and 331 MW of generation for the winter season. The System impact study for the summer season was issued and posted on the RMAO OASIS on March 4, 2008. The System Impact study for the winter case was issued and posted on July 11, 2008.

II. General Description (Project Design Guide – New Generators)

Project Purpose & Scope

Background

Energy Supply has requested two new generators to be installed at Fort St. Vrain. The total net output of the two General Electric CTGs is 269 MW (summer net) / 331 MW (winter net), with a planned back-feed date of January 30, 2009, and a commercial operation in-service date of no later than May 31, 2009. This will result in two new breaker bay and associated relaying and metering in the Fort St. Vrain switchyard.

Future Considerations

The increase in generation will require replacing 17 total 230kV breakers due to increased short-circuit interrupting duty requirements.

FERC and/or NERC Compliance Requirements

Not Applicable

Right of Way

No new right of way needed.

Electrical Features

Transmission Lines: Current Carrying Capacity of Affected/Tapped/New

The new transmission line conductor size will be capable of carrying the newly added generation. These new transmission lines will be terminated into two new bays and will require protective relaying on both ends.

Fault Current

Will replace 15 additional 230kV breakers due to increased short-circuit interrupting duty requirements. Also replace 2 IPO 230 kV breakers at Fort St. Vrain for the capacitor banks.

Electrical Removals & Relocations

There are three static masts that will need to be relocated.

Electrical Installations (Major Equipment)

4 - 230kV Breakers

6 - Metering Units

6 - Surge Arrestors

2 - transmission line relaying packages

Mobile Substation or Transformer

Not needed

AC System

Existing AC panel 3 phase 480/277 volts

DC System

Existing 125VDC has enough spares

Grounding

Will tie into the existing ground grid per Xcel standards.

Lightning Protection

Surge Arrestors will be installed to protect metering units.

Civil Features

Grading & Fencing

Site already graded

Foundations & Structural

New 230kV dead ends, breaker, switches and bus supports will be installed.

Civil Removals & Relocations

None

Control Features

Control Schemes

Transmission Line Protection- Switchyard to CTG5 & CTG6

- Two new transmission lines will require primary and backup protective relays a SEL-311L for the primary and a SEL-321 for the secondary. Both relays will be utilizing fiber for communications.
- PKG-P is a line current differential relay with a backup distance protection.
- PKGS is a Phase and Ground Distance Relay using the following functions in a step distance ground overcurrent and DCB scheme.
 - 1P/Z1G-Z1P will not be set due to the short distance of the line. There will be ground overcurrent protection.
 - Z2-DCB Scheme phase and ground distance set at 120% of the line with a 10 cycle delay.
 - Z3-Phase Distance setting with a 30 Cycle Delay, set to not reach beyond the transformer.
 - Z3-Ground distance setting with a 30 Cycle Delay, set not to reach beyond the transformer.
 - 67GP-DCB Scheme Instantaneous.

Bus Protection

Existing bus differential will be used.

Transformer Protection (230kV high voltage winding)

Energy supply will design the transformer protection.

RTU

The existing RTU has enough points.

Outages

An outage on the north and south bus will be required.

Project and Operating Concerns

There are no concerns at this time.

Related Substation & Transmission Projects

See Network Upgrades for Delivery.

III. General Description (Project Design Guide – Replace Breakers)

Project Purpose & Scope

The purpose of this project is to replace breakers 5315, 5319, 5308, 5300, 5301, 5323, 5312, 5329, 5325, 5311, 5303, 5322, 5327, 5304, 5324, 5316, and 5318 at the Fort St. Vrain substation due to increased fault levels.

FERC and/or NERC Compliance Requirements

Not Applicable

Right of Way

Not Applicable

Electrical Features

Fault Current

New breakers are rated 63 kA.

Electrical Removals & Relocations

Existing oil breakers – 5315, 5319, 5308, 5300, 5301, - will be scrapped.

Existing SF6 breakers - 5323, 5312, 5329, 5325, 5311, 5303, 5322, 5327, 5304, 5324, 5316, and 5318 – are each rated 242 kV, 2000 amps. 40 kA and can be reused where possible.

Electrical Installations (Major Equipment)

New breakers are being installed with 63kA fault current ratings. The replacement breakers for the cap banks will be IPO's.

Control cabinet for the IPO breakers is on the opposite side of the existing breakers. A junction box and additional cable will be required.

New breakers do not have built in potential devices, so CCVT's will be added to provide the synch check function.

AC and DC System, Substation Grounding and Lighting Protection

Breaker replacement has no impact. Existing system should be adequate.

Civil Features

Grading & Fencing

Breaker replacement has no impact. Existing system should be adequate.

Storm Water Permit

Breaker replacement has no impact. Existing system should be adequate.

Foundations & Structural

The existing foundation will work for the new breakers. Provisions will be added to accommodate the additional CCVT's.

Civil Removals & Relocations

None.

Control Features

Control Schemes

RTU will be updated with new breaker alarms related to the SF-6 breakers. RTU capacity is an issue.

Transmission Line Protection

Breaker replacement has no impact. Existing protection will be used with no changes in the protective relays.

Local Annunciation

Existing RTU is near capacity. Annunciators will be installed with new breakers for alarm output to the RTU.

Outages

In most cases the breakers can be isolated for most of the construction, with small outage periods to test and put the breaker in service.

Project and Operating Concerns

None.

Related Projects

11080177 – Generation interconnect

Network Upgrades for Delivery for Project

In general, the network upgrades for delivery shall mean the additions, modifications, and upgrades to the transmission provider's transmission system (PSCo) required at or beyond the point at which the interconnection facilities connect to the transmission provider's transmission system to accommodate the interconnection of the large generating facility (customer) to the transmission provider's transmission system. See FERC 2003-A definitions for further explanation.

IV. Costs Estimates and Assumptions for the Project:

Interconnection

The estimated non-binding good faith total cost for the PSCo Interconnection Facilities and Network Upgrades to provide an Interconnection for the Customer requested generation is:

\$1.859 million for Customer Interconnection Facilities at Fort St. Vrain Station (Customer funded).

\$2.022 million for PSCo Network Upgrades for Interconnection.

Total Estimated cost of Interconnection = \$3.881 million

The estimated costs shown above are “engineering estimates” with an accuracy of $\pm 10\%$. These estimates do not include any costs for any Customer-owned, supplied, and installed equipment and associated design and engineering for the Customer’s facilities.

Delivery

The additional costs for PSCo Transmission Network Upgrades for Delivery of the full new generation output to PSCo native loads were estimated during the System Impact Study at:

\$ 3.999 million² for additional PSCo Transmission Network Upgrades for Delivery

Therefore, the total estimated project cost for the PSCo facilities required for interconnection and delivery is approximately **\$7.880 million**.

The Project Design Guide included in Part III of this report describes the assumptions and additional details associated with this project. The cost responsibilities associated with these facilities shall be handled as per current FERC guidelines.

Cost Summaries and Details

The following is a summary of the interconnection costs and network upgrades required to connect two new simple-cycle gas-fired combustion turbine generators (CTG5 and CTG6, each rated approximately 135MW (summer) / 206 MVA) into the PSCo transmission system at the Fort Saint Vrain 230kV switchyard. The scope of the interconnection facilities and network upgrades were identified in Non-Queued Study Report labeled NQ-2007-2 provided by PSCo Transmission System Planning on October 19, 2007.

² Engineering level estimate considered to have an accuracy of +/- 10%.

Planning – reorganize table?

Facility	Description	Cost
Fort Saint Vrain 230kV Switching Station	Interconnection Facilities funded by TAM: <ul style="list-style-type: none"> • Expand two 230kV buses to the east • Install two 230kV bays in the Breaker & Half, one interconnection point per bay • Four 230kV circuit breakers • Ten 230kV gang switches • Associated foundations, structures, and yard work 	\$2,021,503
Fort Saint Vrain 230kV Switching Station	Network Upgrades funded by TAM: <ul style="list-style-type: none"> • Replace 15 additional 230kV circuit breakers due to insufficient fault duty 	\$3,453,066
Fort Saint Vrain 230kV Switching Station	Operations and Maintenance Costs funded by TAM: <ul style="list-style-type: none"> • Relocate 50MVAR capacitor bank to the west of current position 	\$28,194
Fort Saint Vrain 230kV Switching Station	Interconnection Costs funded by Customer: <ul style="list-style-type: none"> • Metering instrument transformers (set of three per interconnection) • Two dead-end towers • Metering panel equipment • Associated foundations, structures, and bus work 	\$563,550
Fort Saint Vrain 230kV Switching Station	Interconnection Costs funded by Customer: <ul style="list-style-type: none"> • 230kV bus tie connection to generating facilities 	\$1,172,123
Fort Saint Vrain Generating Plant	LF/AGC Costs funded by Customer: <ul style="list-style-type: none"> • Load control RTU • All required cabinets, wiring, and associated controls equipment 	\$123,280
Fort Lupton – Fort St. Vrain 230kV Lines 5311, 5329	Network Upgrade funded by TAM: Reconductor 15 spans (2.5 miles) of existing double-circuit 230kV transmission line <ul style="list-style-type: none"> • 1033.5 Ortolan conductor (540 MVA) 	\$447,011
Cherokee Substation	Network Upgrade funded by TAM: Upgrade line termination jumpers on Cherokee - Lacombe 230kV Ckt #5057	\$23,522

Facility	Description	Cost
Hogback Substation	Network Upgrades funded by TAM: <ul style="list-style-type: none"> Upgrade line termination jumpers on Hogback – Lookout 115kV Ckt #9794 Upgrade line termination jumpers on Hogback – Soda Lakes 115kV Ckt #9794 	\$47,073
	Total Interconnection Costs by TAM	\$2,021,503
	Total Network Upgrades by TAM	\$3,970,642
	Total Operations & Maintenance Costs by TAM	\$28,194
	Total Interconnection Costs funded by Customer	\$1,858,753
Total	1. Total cost of GI-2007-11 (Not including previously funded Valmont Autos)	\$7,879,092
Time Frame	See Schedule – Figure 2	

230kV Bus Fault Current Ratings – Fort Saint Vrain Switching Station

The 230kV bus fault currents at the Fort Saint Vrain switching station, with the addition of the new CTG5 & CTG6 generation, are as follows:

Single-line to Ground Fault: ~40,783A < -85.7 deg
 3-Phase Fault: ~38,949A < -86.1 deg

V. GI-2007-11 Fort St. Vrain Generation Addition Assumptions

- The cost estimates provided are “engineering estimates” with an accuracy of +/- 10%.
- All applicable overheads are included. AFUDC has been excluded.
- There is no contingency added to the estimates.
- All estimates are in 2008 dollars.
- No overtime is included in the labor estimates.
- PSCo (or its contractor) crews will perform all construction and wiring associated with PSCo-owned and maintained equipment.
- No siting or permitting work will be required.
- A Certificate of Public Convenience and Necessity (CPCN) has been granted from the Colorado Public Utility Commission (CPUC) for the PSCo generation addition (GT5 & GT6, NQ-2007-2 / GI-2007-11) project, and has been granted by the CPUC.
- Spare fiber optics between plant and switchyard.
- All required transmission outages necessary to support construction would be obtained as needed.
- Assumes a dedicated construction force to the project (in-house crews).

- Construction of new substation facilities is within existing property boundaries.
- Back-feed date of new generation is 1/30/2009. Interconnection facilities must be complete by this date.
- Commercial date of new generation is 5/31/2009. All network upgrades other than the 15 additional breaker replacements must be completed by this date. Additional breaker numbers requiring replacement:
 - 5300, 5301, 5303, 5304, 5308, 5311, 5312, 5315, 5319, 5322, 5323, 5324, 5325, 5327, 5329.
- Breaker replacements are anticipated to be complete by 2nd quarter, 2010.
- PSCo needs approximately 2-4 weeks to test requirements of Interconnection Guidelines For Transmission Interconnected Producer-Owned Generation Greater Than 20 MW. Much of the testing can be performed in parallel with the construction schedule.
- PSCo meters will be 4 quadrant, bi-directional meters with recorders. Meters/recorders will be equipped such that they can be accessed remotely through a phone circuit.
- PSCo will engineer, procure, construct, own, and maintain all 230kV facilities associated with the substation expansion.

VI. Engineering, Procurement & Construction Schedule
Figure 2: Fort St. Vrain Preliminary / Draft Schedule

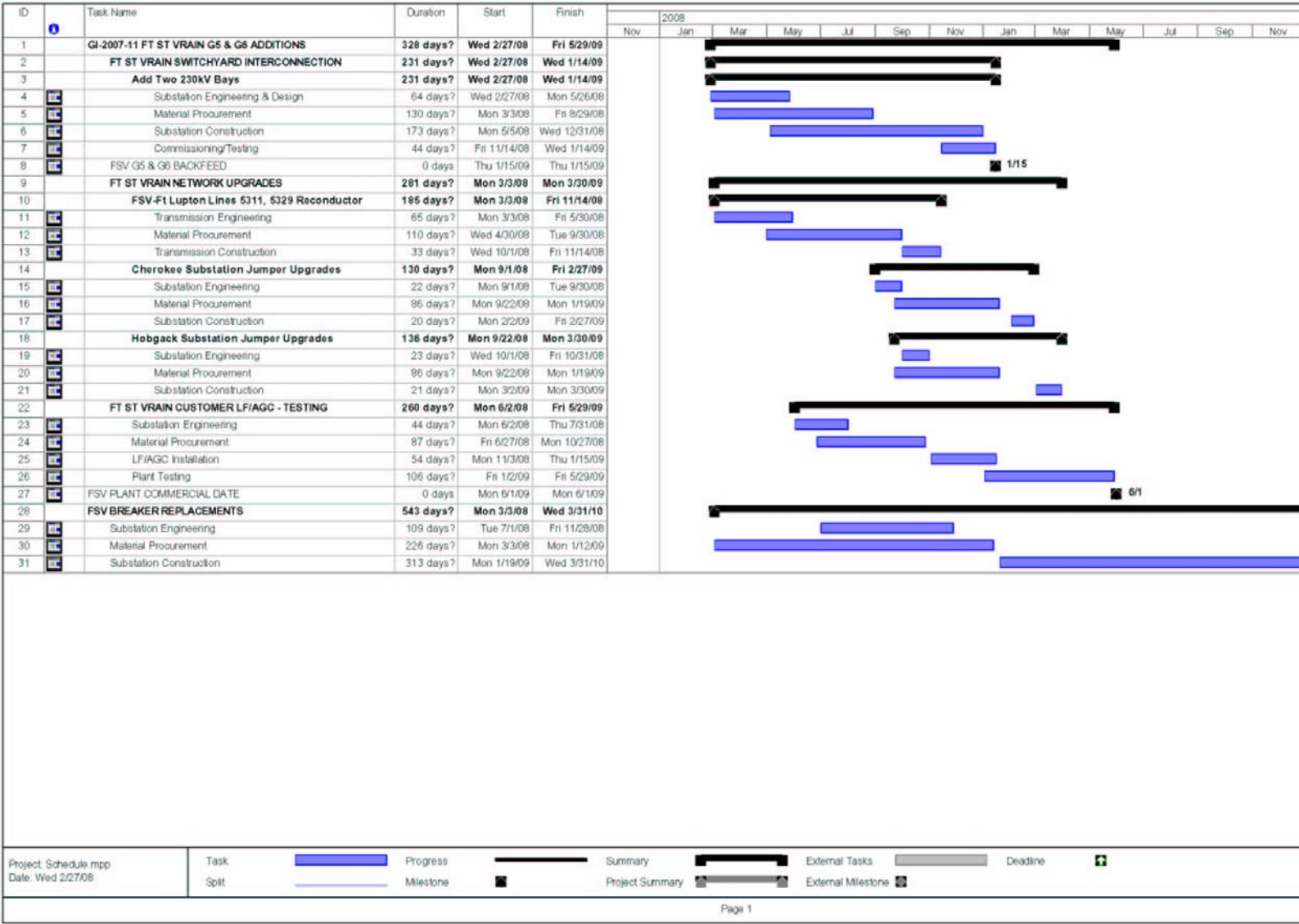

Figure 3: Fort St. Vrain Switchyard: Proposed General Arrangement Drawing as a Stand Alone Project

