

**(DRAFT)**  
**Feasibility Study Report**  
**Request # GI-2007-5**

50 MW Wind Expansion of Cedar Creek, near Grover, Colorado  
in 4<sup>th</sup> Quarter 2008

PSCo Transmission Planning  
October 2, 2007

**Executive Summary**

Public Service Company of Colorado (PSCo) Transmission Planning received on or about March 28, 2007 a generation interconnection request to determine the feasibility of a 50 MW expansion of an existing Customer's Cedar Creek wind turbine generation facility, for injecting additional power into the PSCo transmission system at the Keenesburg 230 kV Switching Station in Weld County, Colorado. The Customer's original Cedar Creek generation interconnection request was for 300 MW wind facility near the town of Grover, Colorado, with transmission feasibility studies completed under the request GI-2006-1 (i). The Customer requested a commercial operation date for the 50 MW expansion of December 31, 2008. This request was studied as both an Energy Resource (ER)<sup>1</sup> and a Network Resource (NR)<sup>2</sup>. Transmission studies show that before the 50 MW Cedar Creek expansion becomes commercial PSCo must complete the Cherokee – Silver Saddle 230 kV transmission line uprate. This project has not been approved in the budget and has an approximate cost of \$990,000 with an estimated completion time of 12 months. Therefore, the requested Customer commercial operation date is not feasible. The request was studied as a stand-alone project only.

This interconnection request was evaluated under four (4) different options and consisted of evaluating delivery of the Customer's generation to different native loads on a firm basis. These delivery options included: Option (A) PSCo, Option (B) Platte River Power Authority (PRPA), Option C: Colorado Springs Utilities (CSU) and Option (D) Tri-State Generation and Transmission (TSGT). The present study considered

---

<sup>1</sup> **Energy Resource Interconnection Service (ER Interconnection Service)** shall mean an Interconnection Service that allows the Interconnection Customer to connect its Generating Facility to the Transmission Provider's Transmission System to be eligible to deliver the Generating Facility's electric output using the existing firm or non-firm capacity of the Transmission Provider's Transmission System on an as available basis. Energy Resource Interconnection Service in and of itself does not convey transmission service.

<sup>2</sup> **Network Resource Interconnection Service** shall mean an Interconnection Service that allows the Interconnection Customer to integrate its Large Generating Facility with the Transmission Provider's Transmission System (1) in a manner comparable to that in which the Transmission Provider integrates its generating facilities to serve native load customers; or (2) in an RTO or ISO with market based congestion management, in the same manner as all other Network Resources. Network Resource Interconnection Service in and of itself does not convey transmission service.

network infrastructure in PSCo transmission system and monitored the other entities' regional transmission system.

Transmission studies show that the original planned 300 MW Cedar Creek Large Generation Facility, in conjunction with the proposed 50 MW Large Generation Facility expansion at Cedar Creek does not supply the reactive power support necessary at the POI at Keenesburg 230 kV bus to operate across the +/- 0.95 range<sup>3</sup>. The additional equipment necessary to meet the requirements has not been modeled in this present study and will be evaluated in detail during the System Impact Study, should the Customer like to proceed with such a request.

Any Interconnection Agreement (IA) requires that certain conditions be met, as follows:

1. The conditions of the Interconnection Guidelines<sup>4</sup> are met.
2. A single point of contact is given to Operations to manage the Transmission System reliably for all wind projects (GI-2006-1 (i) and GI-2007-5).
3. Customer must show the ability to control power factor and provide voltage support as measured at the POI, across the required +/- 0.95 power factor range.
4. PSCo will require testing of the full 350 MW of the facility. These tests will include but not limited to power factor capability and voltage control at the POI for various generation output levels (0 to 350 MW) of the Customer's wind generation facility. Appendix C provides a typical testing plan.

These studies indicated that the current Customer's transmission line design at full wind output (350 MW) does not meet the voltage and power factor requirements, without installing additional static and/or dynamic VAR support equipment at either the Customer's Cedar Creek site or at the POI at Keenesburg 230 kV Sub. A heavy summer power flow model case shows that without this additional VAR support equipment, the Customer's Cedar Creek wind farm is not able to maintain the +/- 0.95 power factor requirement as measured at the POI.

The Customer needs to determine a solution to the generators or transmission line to meet the voltage and power factor guidelines described in the Interconnection guidelines. Additional transmission reinforcements may be required that have not been evaluated in this study, and would be determined in the following System Impact Study.

## **Stand Alone Results**

The stand-alone results assume that the original planned Customer Cedar Creek Large Generation Facility (GI-2006-1 (i)) interconnecting at the Keenesburg 230 kV bus is modeled in the power flow case at full output, or approximately 300 MW, and Rocky Mountain Energy Center (RMEC) is modeled at its full 600 MW output. The results also

---

<sup>3</sup> The System Impact Study will evaluate this power factor / Var voltage support requirement to maintain system reliability and integrity during contingencies and system faults.

<sup>4</sup> Interconnection Guidelines for Transmission Interconnected Producer-Owned Generation Greater than 20 MW, version 3.0 12/31/06.

assume that the Customer complies with FERC Order 661-A guidelines for Low Voltage Ride Through<sup>5</sup>, and that the conditions of PSCo's Interconnection Guidelines<sup>6</sup> are met. Additional studies are presently being conducted with the Customer to ensure these conditions are satisfied<sup>7</sup> for this 300 MW Large Generation Facility, planned for in service in late 2007.

Energy Resource (ER):

The ER portion of this study determined that the Customer could provide 0 MW of the Cedar Creek expansion of firm energy without the construction of network upgrades. This determination is based on the Cherokee – Silver Saddle 230 kV transmission line uprate that must be completed prior the commercial operation of the 50 MW Cedar Creek expansion. Additional details can be found in the results section.

Network Resource (NR):

The Customer can provide the full 50 MW Cedar Creek expansion once the Cherokee – Silver Saddle 230 kV transmission line uprate is completed.

---

<sup>5</sup> LVRT Guidelines are located at [www.ferc.gov](http://www.ferc.gov).

<sup>6</sup> Interconnection Guidelines for Transmission Interconnected Producer-Owned Generation Greater than 20 MW, version 3.0 12/31/06.

<sup>7</sup> The Facility Study for GI-2006-1(i) issued on November 17, 2006 addresses these concerns.

**Figure 1: Existing PSCo Transmission System Network Upgrades for GI-2007-5.**  
 (This is a simplified 230 kV system diagram and does not include all system details)

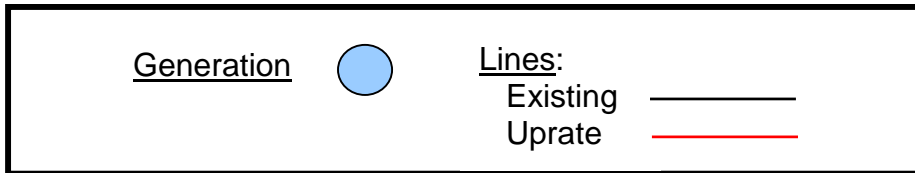
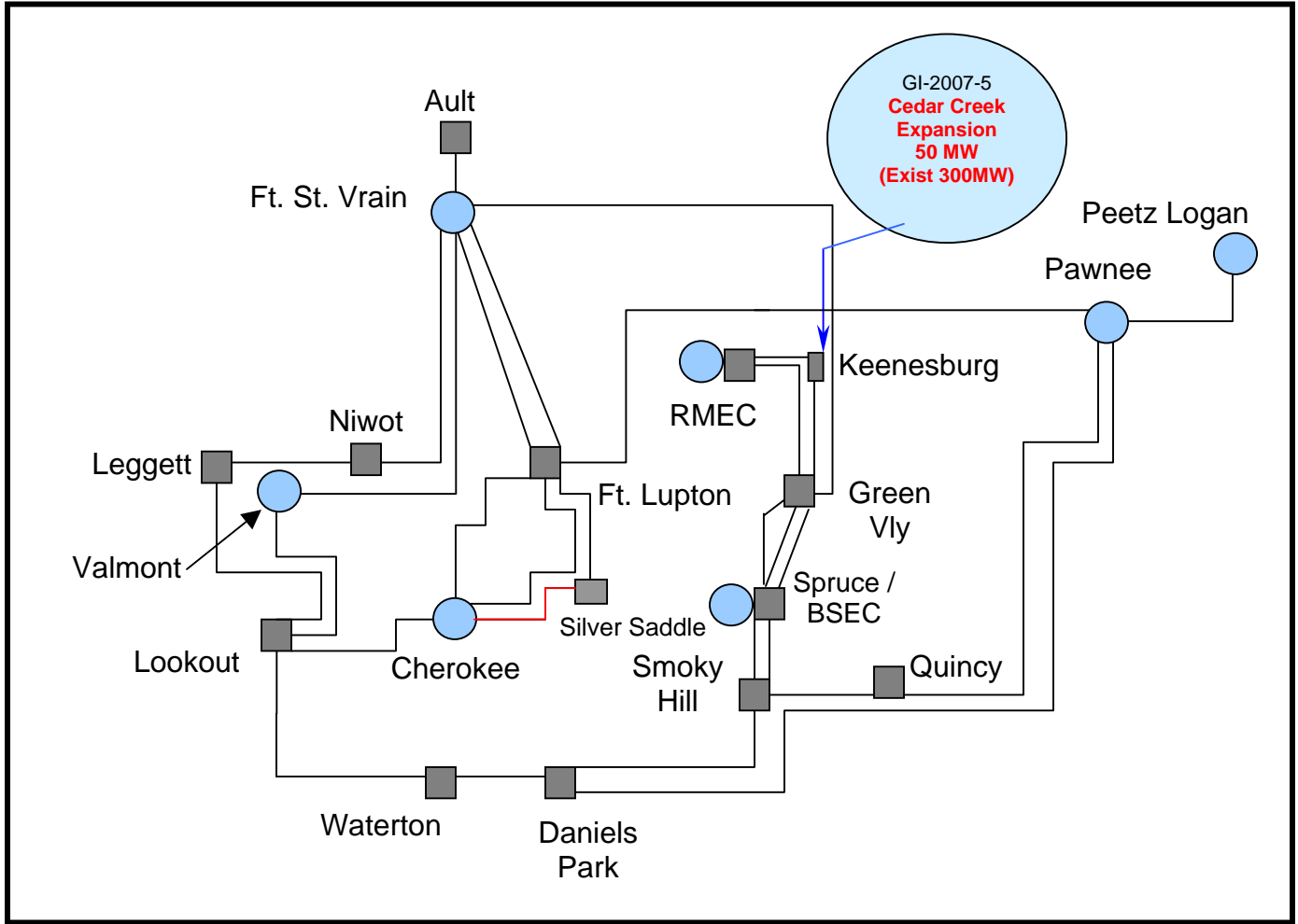

**Figure 2: Simple Diagram of the Keensburg Interconnection**

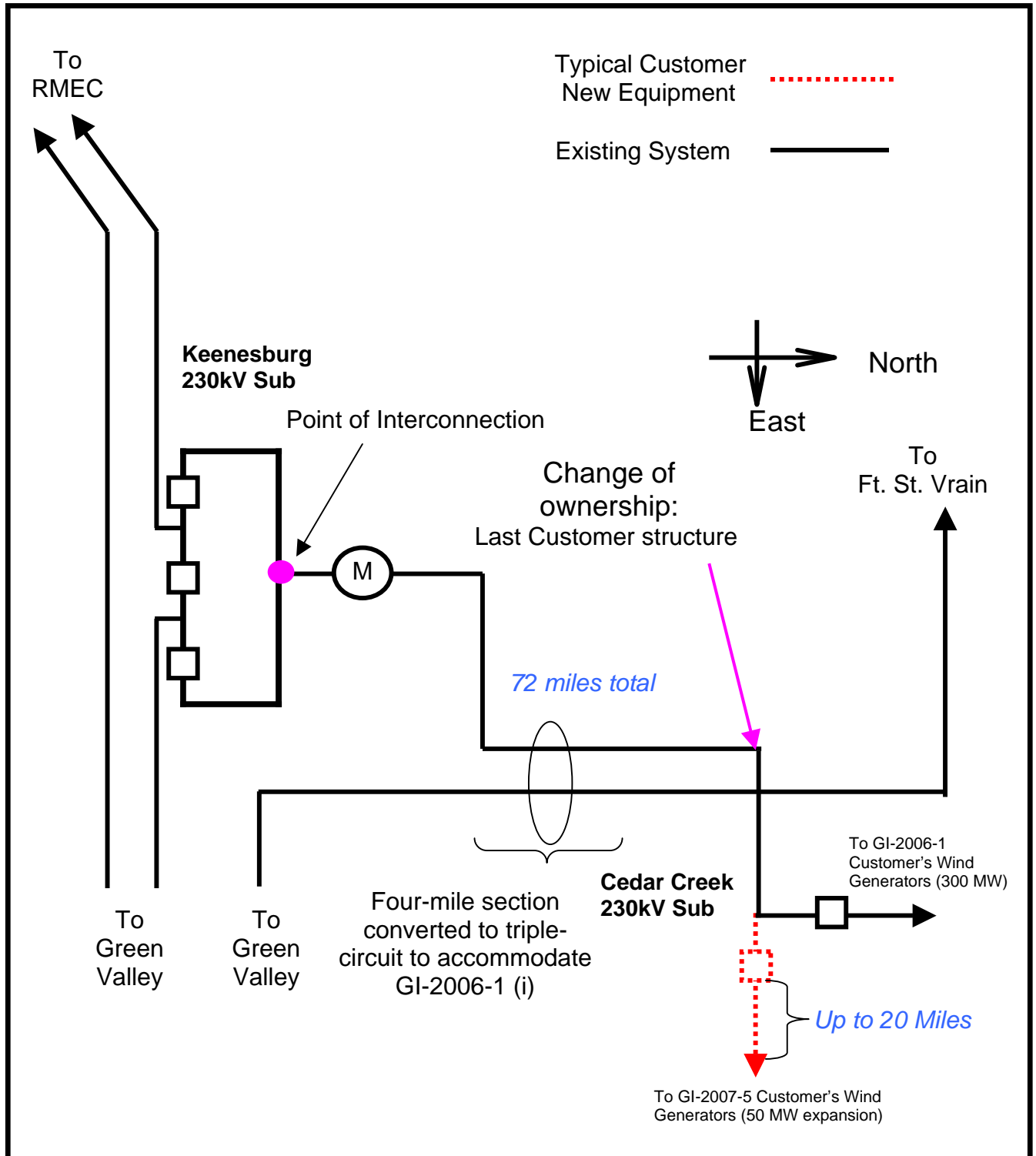

## **Customer's generation delivery to PRPA, CSU and TSGT load**

The 50 MW Cedar Creek expansion project does not have a negative impact on the PSCo's transmission system when the customer's generation is delivered to the native load of PRPA, CSU and TSGT. However, the receiving entities' regional transmission systems (PRPA, CSU and TSGT) were monitored but not evaluated in detail for system reliability and integrity during the power transfers for the Large Generator expansion project to the receiving entities' native load. During these scenarios the receiving entities' generators were re-dispatched (lowered) to accommodate the proposed 50 MW Cedar Creek Large Generation Facility expansion.

Additional details of the studies can be found under the Power Flow Study Results and in the appendix.

## **Introduction**

PSCo Transmission Planning originally received a large generator interconnection request (GI-2007-5) on or about March 28, 2007 to interconnect twenty 2.5 MW, Clipper Wind power wind turbines, for a total of 50 MW wind generation expansion of the existing Customer's 300 MW wind facilities at Cedar Creek planned to be in-service by late 2007 (GI-2006-1 (i)). The Customer requested a commercial operation date for the expansion facilities of December 31, 2008. Transmission studies show that before the 50 MW Cedar Creek expansion becomes commercial PSCo must complete the Cherokee – Silver Saddle 230 kV transmission line uprate. This project has not been approved in the budget and has an approximate cost of \$990,000 with an estimated completion time of 12 months. Therefore, the requested Customer commercial operation date is not feasible. The proposed wind farm (Project) would be located at the Cedar Creek wind facilities, near Grover, Colorado and would interconnect into the PSCo transmission system via the Customer's existing 72-mile radial 230 kV line terminating at the PSCo Keenesburg Substation. This transmission line has been completed and is part of GI-2006-1 (i) interconnection project. The Customer has requested that this Project be evaluated as a Network Resource (NR) and an Energy Resource (ER) with several delivery options. Under the different options, the Customer's generation would be delivered to PSCo, PRPA, CSU and TSGT native loads.

## **Study Scope and Analysis**

The Interconnection Feasibility Study evaluated the transmission requirements associated with the proposed interconnection to the PSCo Transmission System. It consisted of power flow and short circuit analyses. The power flow analysis provided a preliminary identification of any thermal or voltage limit violations resulting for the interconnection, and for a NR request, a preliminary identification of network upgrades required to deliver the proposed generation to PSCo loads. The short circuit analysis identified any circuit breaker short circuit capability limits exceeded as a result of the

Interconnection and for a NR request, the delivery of the proposed generation to PSCo loads.

PSCo adheres to NERC / WECC Reliability Criteria, as well as internal Company criteria for planning studies. During system intact conditions, criteria are to maintain transmission system bus voltages between 0.95 and 1.05 per-unit of system nominal / normal conditions, and steady state power flows within 1.0 per-unit of all elements' thermal (continuous current or MVA) ratings. Operationally, PSCo tries to maintain a transmission system voltage profile ranging from 1.02 per-unit or higher at generation buses, to 1.0 per-unit or higher at transmission load buses. Following a single contingency element outage, transmission system steady state bus voltages must remain within 0.90 per-unit to 1.10 per-unit, and power flows within 1.0 per-unit of the elements continuous thermal ratings.

For this project, affected parties include Western Area Power Administration (WAPA), Tri-State Generation and Transmission (TSGT), Platte River Power Authority (PRPA) and Colorado Springs Utilities (CSU). These parties will receive a copy of this feasibility study report.

### **Power Flow Study Models**

The power flow studies were based on a PSCo developed 2010 heavy summer base case that originated from the Western Electricity Coordinating Council (WECC) 2011 heavy summer base model. Load levels were adjusted to reflect 2010 system conditions. The 50 MW Cedar Creek Large Generation Facility expansion was modeled as one 50 MW conventional generator, with a VAR capability range from 0.95 per unit (p.u.) lagging power factor (overexcited), to 0.95 p.u. leading power factor (under-excited), which the Customer has stated to be the p.f. capability of the Clipper 2.5 MW model Generator. The project generation was scheduled to the southern PSCo system by reducing generation in that area. Other generation was re-scheduled during the evaluation the Customer's request to the other entities' native load.

To evaluate the capabilities and system requirements for firm transfer levels, the powerflow model was modified to simulate TOT 3 path flows at approximately 1,350 MW. Efforts were made to include in the models all budgeted and approved transmission projects expected to be in service for the 2010 heavy summer season. The studies assumed 2010 peak summer demand conditions in the PSCo system and in other utility systems.

The present power flow study for the interconnection request GI-2007-5 did not include any reactive power management system at the customer's 34.5 kV collector system nor at the POI, as it required to meet FERC Order 661-A on Low Voltage Ride Through (LVRT) requirements and stated in the Facility Study for GI-2006-1 (i). Furthermore, the present power flow study did not model any equipment needed to maintain the PSCo's power factor requirements at the POI. These issues are being considered and evaluated in great details on a separate study with the Customer, and the results will be

incorporated during the System Impact Study stage of the present interconnection request (GI-2007-5), should the customer decide to proceed with such a study.

## **Power Flow Study Results and Conclusions**

### **Energy Resource (ER) Study Results**

The ER portion of this study determined that the Customer could provide 0 MW of the Cedar Creek expansion of firm energy without the construction of network upgrades. This determination is based on the Cherokee – Silver Saddle 230 kV transmission line uprate that must be completed prior the commercial operation of the 50 MW Cedar Creek expansion. The Cherokee – Silver Saddle 230 kV transmission line uprate must be implemented before the 50 MW Cedar Creek expansion becomes operational. The limiting factor is the existing Cherokee – Silver Saddle 230 kV transmission line de-rate, which overloads up to 121% with the loss of the Green Valley to Reunion 230 kV transmission line. This project has been identified in the internal PSCo Transmission Planning budget cycle. The pre-50 MW Cedar Creek expansion overload on the Cherokee – Silver Saddle 230 kV transmission line is 118%.

### **Network Resource (NR) Study Results**

The Customer can provide the full 50 MW Cedar Creek expansion once the Cherokee – Silver Saddle 230 kV transmission line uprate is completed.

### **Voltage Control at the Point of Interconnection**

Studies show that the 50 MW expansion project in conjunction with the planned 300 MW facilities, under certain conditions cannot meet the power factor and voltage requirements as mandated by PSCo in their Interconnection Guidelines for Transmission Interconnected Producer-Owned Generation Greater than 20 MW (Guidelines). In addition, studies show that during high levels of wind generation the 230 kV line from the Cedar Creek Wind Farm to the POI at Keenesburg is absorbing excessive reactive power from the existing PSCo transmission system at the Keenesburg 230 kV bus. This is an unacceptable operating condition. The Customer needs to demonstrate that the Guidelines are met. This includes identifying any additional VAR support equipment, such as dynamic and/or switched static capacitors, that would be installed by the Customer at their site, Cedar Creek 34.5 kV collector system, or at the POI, Keenesburg 230 kV bus, in order to meet the power factor and voltage requirements. In addition, PSCo requires that the Customer provide a single point of contact<sup>8</sup> to coordinate compliance with the power factor/voltage regulation at the POI. The Customer will need to control<sup>9</sup> the VAR flow on their line, as measured at the Keenesburg 230 kV POI, in accordance with the Interconnection Guidelines.

---

<sup>8</sup> The POI will provide a point of injection of wind generation from several different entities.

<sup>9</sup> This requirement will be evaluated in the System Impact Study.



### **Short Circuit Study Results**

The short circuit study results show that the fault current levels for all buses studied are within the interrupting ratings of the breakers; therefore, the Project and associated infrastructure will not cause fault current to exceed the circuit breaker ratings.

The total 230 kV bus fault currents for a 2012 case model, for 230 kV bus faults at the Keenesburg 230 kV bus are approximately 16,000 amps for a single-line to ground fault, and 17,000 amps for a three-phase fault. These values assume only a small fault current contribution from the proposed wind facility, or only slightly more than the wind TG's normal full load amp rating. This is typical for this type of generator.

### **Costs Estimates and Assumptions**

The estimated total cost for the required upgrades is **\$38,400**.

The estimated costs shown are (+/-30%) estimates in 2007 dollars and are based upon typical construction costs for previously performed similar construction. These estimated costs include all applicable labor and overheads associated with the engineering, design, and construction of these new PSCo facilities. This estimate did not include the cost for any other Customer owned equipment and associated design and engineering.

The estimated costs and time frame to complete the Cherokee – Silver Saddle 230 kV transmission line uprate are not included in the following section since this project may be evaluated and recommended for the internal PSCo budget cycle. However, it is anticipated that the uprate may cost approximately \$990,000 with a completion time of 12 months.

This estimate does not include transmission reinforcements that may be required to deliver the 50 MW expansion at Cedar Creek to PRPA, CSU and TSGT and maintain the receiving entities' system reliability and integrity. This estimate does not include any network reinforcements that may be required to meet the interconnection guidelines as mandated by PSCo in their Interconnection Guidelines for Transmission Interconnected Producer-Owned Generation Greater than 20 MW (Guidelines).

The following tables list the improvements required to accommodate the interconnection and the delivery of the Project. The cost responsibilities associated with these facilities shall be handled as per current FERC guidelines. System improvements are subject to change upon more detailed analysis.

Since this project intends to use the interconnection from the 300 MW Wind Facilities GI-2006-1(i) at Keenesburg substation, there will be only minimal costs of \$38,400 associated with the interconnection required for this 50 MW expansion project GI-2007-5.

**Table 1: PSCo Transmission Provider’s Interconnection Facilities (Customer funded)**

Element	Description	Cost (\$Million)
<b>Keenesburg Switchyard</b>	Miscellaneous work needed to interconnect the customer’s 50 MW expansion project: <ul style="list-style-type: none"> <li>• Relaying and metering</li> <li>• SCADA upgrades at control center</li> </ul>	<b>\$0.04</b>
<b>Time Frame</b>	<b>Substation &amp; Transmission</b>	<b>6 months</b>
<b>Total</b>	<b>Transmission Provider’s Interconnection Facilities</b>	<b>\$0.04</b>

**Major Assumptions related to Table 1.**

- The estimated costs provided are “Scoping Estimates” with an accuracy of  $\pm 30\%$ .
- All applicable overheads are included. AFUDC has been included with the PSCo Network Upgrades and removed from the Customer Interconnection Facilities.
- There is no contingency added to the estimates.
- Estimates have not been escalated. All estimates are in 2007 dollars.
- PSCo (or its contractor) crews will perform all construction and wiring associated with PSCo-owned and maintained equipment.
- All required transmission outages necessary to support construction are assumed that can be obtained as needed.

# Appendix A

## Power Flow Study Assumptions

## **Assumptions for Cedar Creek Wind Farm Facility Expansion Study**

The following is a list of basic assumptions taken while evaluating the feasibility of the interconnection request GI-2007-5. These assumptions depict the power flow models used and system conditions, as well as the wind generation models including location during the evaluation this feasibility study.

### Assumptions on PSCo system:

- Transmission projects modeled have been approved in the Capital Budget
- Planned original (GI-2006-1) Cedar Creek Wind Facility modeled at full output, or 300 MW, but since this facility is still undergoing design changes, the detailed model was not used because it is not available from the Customer. In this study, the 300 MW facility was modeled as two 150 MW GE SLE Turbines with a +/-0.95 power factor at the generator terminals. However, the actual planned facility will be comprised of 80 MW of GE SLE synchronous type wind turbine generators, and 220 MW of Mitsubishi induction type wind turbine generators.
- Proposed 50 MW Cedar Creek Large Generation Facility expansion modeled as a single 50 MW conventional generator, with a range of Var output capability corresponding to a range of power factor from 0.95 per unit (p.u.) lagging power factor (overexcited), to and a 0.95 p.u. leading power factor (under-excited).
- Proposed 50 MW Cedar Creek Large Generation Facility expansion modeled at the planned Customer's 230 kV Cedar Creek switching station (actual location may be up to 20 miles from the switching station)
- Planned Peetz Logan Wind Facility modeled at 10% capacity output, or 40 MW.
- Power transfers from Wyoming into Colorado (TOT3) level is approximately 1,350 MW. (WECC approved case was approximately 1,150 MW)

### Assumptions on Customer's planned and proposed wind facilities:

- Customer will comply with FERC Order 661-A guidelines for Low Voltage Ride Through.
- Customer will provide both dynamic and static reactive support equipment to meet voltage support and power factor control requirements at the point of interconnection.

- Customer will engineer, procure, and construct all equipment up to the PSCo's Point of Change of Ownership at the Keenesburg 230 kV bus. This includes transmission line relay/communication equipment at Customer's site.

Pertinent modeling adjustments/assumptions:

- o The generation at the original planned Cedar Creek facility was modeled at full output, or approximately 300 MW, as conventional GE doubly-fed induction type wind turbine generators (DFIG, with similar VAr capability / action to synchronous type generators), rather than as the actually planned combination of 80 MW of DFIG plus 220 MW of induction wind turbine generators.
- o The equipment required to comply with FERC Order 661-A guidelines for Low Voltage Ride Through was not modeled in the power flow analysis.
- o Any additional VAr support equipment that may be required to meet the PSCo voltage support requirements and power factor control requirements as measured at the point of interconnection (Keenesburg 230 kV bus) was not modeled in the power flow analysis.
- o The generation at the planned Peetz Logan facility interconnecting at Pawnee 230 kV bus was modeled at 10% capacity, or approximately 40 MW.
- o Study models included a planned upgrade of the existing Smoky Hill to Spruce 230 kV double circuit line to 800 MVA. These upgrades are projected to be completed in early 2008.
- o Study models included a planned upgrade of the existing Smoky Hill to Meadow Hills 230 kV line to 525 MVA. These upgrades are projected to be completed in early 2008.
- o Network upgrades for GI-2006-1 were implemented in the power flow models.

The Point of Interconnection (POI) between the Customer's Cedar Creek site and PSCo's transmission system is assumed to be the point at which the Customer's 72-mile 230 kV transmission line connects to the PSCo Keenesburg 230 kV substation bus. The 72-mile line was modeled per the Customer provided information:

- A single-circuit 72-mile, 230 kV line using a combination conventional 230 kV "H-frame" wood pole and single steel pole construction with a double bundled conductor 954 ACSR per phase, with a 800 MVA rating.
- Four 230-34.5 kV, 100/133/167 MVA Customer main transformers, located at the Customer collector site at Cedar Creek.

# Appendix B

## Contingency Results

**Table 2: Contingency Comparison Table of Most Significant Contingencies**

Overload Branches	Rate (MVA)	Bench Mark		Contingency	
		2010 HS (Load %)	2010 HS + CCWE 300 MW (Load %)		2010 HS + CCWE 350 MW (Load %)
Smoky Hill - Peakview 115 kV	187	115	125	125	Smoky Hill - Murphy 230 kV
Barr Lake - Reunion 230 kV	435		103	109	Ft. Lupton - JL Green 230 kV
Green Valley - RMEC 230 kV	834		103	109	Green Valley - Keenesburg 230 kV
Green Valley - Keenesburg 230 kV	834				Green Valley - RMEC 230 kV
Cherokee - Conoco 115 kV	135	103	106	107	Ckerokee - Mapleton 115 kV
Cherokee - Silver Saddle 230 kV	326		110	113	Ft. Lupton - JL Green 230 kV
Silver Saddle - Reunion 230 kV	326	106	118	121	Ft. Lupton - JL Green 230 kV

# Appendix C

## Typical Commercial Testing Document



**Table 3: Typical Testing Plan**

**Cedar Creek 2 Wind Project, 350 MW**

Test Sheet DRAFT-Based on Power Factor Control as Primary Operating Mode (we may decide on voltage control as primary). We understand that the plant is capable of either.

*NOTE\*\* Performance test period begins upon 1) successful commissioning of all turbines and other major electrical equipment to be connected to the Peetz-Logan Interconnect and 2) SCADA in place, with all points available and active, including Lookout to Wind Plant and Wind Plant to FPL Remote Operations*

Requirement	Specific Req.	Test	Pass	Conditions	
1 Power Factor control at Point of Interconnection (POI)	Maintain unity p.f.	Set to 1.00 p.f.	Variability recorded and noted	0-P(rated): 0--->350-->0 twice, not curtailed to achieve zero.	Demonstrates normal plant operation over full range using normal reactive power control
2	Fully compensated (demonstrate full reactive power compensation for line/collector capacitance)	Set to 1.00 p.f.	Mvar <=0, report reactive shunts in use, or other source(s) of reactive compensation	0 MW output, all turbines off, 2+ hours, not curtailed to achieve zero.	Demonstrates compliance with TICL II.I (ref. LGIG III.F), requiring plant to not have leading power factor at less than 50% load levels. Lead/Lag 0.98 p.f. required at 50+% customer load.
3	Lead/Lag 0.95 limits	Set to 0.950 p.f. Lead	Capability measured and recorded	>92.5% P(rated)=325 MW	Demonstrates plant reactive power capability at high output (ref. NERC Standard TOP-002 R13)
4		Set to 0.950 p.f. Lag	Capability measured and recorded	>92.5% P(rated)=325 MW	
5	Lead/Lag setpoints	Set to 0.990 p.f. Lead	Measured and recorded	>50% P(rated)=175 MW	Demonstrate plant reactive control at lower output levels (ref. NERC Standard TOP-002 R13)
6		Set to 0.970 p.f. Lead	Measured and recorded	>50% P(rated)=175 MW	
7		Set to 0.990 p.f. Lag	Measured and recorded	>50% P(rated)=175 MW	
8		Set to 0.970 p.f. Lag	Measured and recorded	>50% P(rated)=175 MW	
9 Voltage control at POI	Raise/lower setpoint	Series selected at time of test, e.g., "raise 2 kV"	right direction, e.g., raise not lower, as requested, subject to p.f. limits	>50% P(rated)=175 MW	Demonstrate voltage control functionality (ref. NERC Standard TOP-002 R13)
10		Volt raise 2, as above	right direction, e.g., raise not lower, as requested, subject to p.f. limits	>50% P(rated)=175 MW	
11		Volt lower 1, as above	right direction, e.g., raise not lower, as requested, subject to p.f. limits	>50% P(rated)=175 MW	
12		Volt lower 2, as above	right direction, e.g., raise not lower, as requested, subject to p.f. limits	>50% P(rated)=175 MW	
13		Hold voltage setpoint	Setpoint selected at time of test, e.g., 1.01 p.u.	voltage held within +/- 1% as plant is capable, variability recorded and noted	
14 Communication	Responsiveness	Series of reasonable requests, e.g., "switch to voltage control mode", "report # turbines online", "report status of shunt caps & reactors	Professional, prompt (within one minute) response, accurate and complete. 100% compliance for one week.	0-P(rated)=0-350 MW, full range at least once during test period.	Demonstrates responsiveness of operator and ability to view and control plant. (ref. LGIG VI.J)
15	Physical link	documented dedicated circuit, Lookout-wind op center	documentation submitted prior to operational testing.	no operational requirement	NOTE: I think the line has been completed. I do not have the documentation.
16		site visit to observe wind operations center (most likely RTP or Op engineer or manager)	Written summary of how control center works, and first hand validation.	no operational requirement	Demonstrate compliance with operator requirements (ref. LGIG VI.J)