



Interconnection Feasibility Study Report Request # GI-2008-18

300 MW Wind Project
Interconnected at the Comanche 345 kV switchyard

PSCo Transmission Planning
November 11, 2009

A. Executive Summary

The purpose of the Interconnection Feasibility Study is to provide a preliminary evaluation of the system impact and cost of interconnecting the Generating Facility to the Transmission Provider's Transmission System, the scope that is described in the Standard Large Generator Interconnection Procedures.

On August 27, 2008, Public Service Company of Colorado (PSCo) received a generation interconnection request to determine the possible impacts of interconnecting a proposed new 300 MW wind powered generation plant, located in the Walsenburg area in southern Colorado, to the Comanche 345 kV Bus. The Customer's project facility is to consist of 182 Vestas V82-1.65 MW wind turbine generators, with an associated collector system to step up the voltage from 34.5 kV to 345 kV at the Customer wind site.

The Customer requested the primary Point of Interconnection (POI) be the 345 kV bus at the Comanche Substation with the 230 kV bus at the Walsenburg Substation as an assumed secondary POI. The second POI was not studied with this request because Walsenburg is not a PSCO facility.

The study was conducted assuming the wind farm would connect into the PSCo 345 kV transmission system via a Customer-owned and constructed 50-mile, 345 kV transmission line (see Figure 1 and Appendix A). The Commercial Operation Date¹ requested by the Customer is October 31, 2012 and the Back-Feed In-Service Date² is April 30, 2012.

The investigation included steady-state power flow and short circuit studies but did not include transient dynamic stability studies. The request was studied as a stand-alone project only, with no evaluations made of other possible new generation requests that may exist in the LGIP queue

¹ **Commercial Operation Date** of a unit shall mean the date on which the Generating Facility commences Commercial Operation as agreed to by the Parties pursuant to Appendix E to the Standard Large Generator Interconnection Agreement

² **In-Service Date** shall mean the date upon which the Interconnection Customer reasonably expects it will be ready to begin use of the Transmission Provider's Interconnection Facilities to obtain back-feed power.



other than the generation projects that are already approved and planned to be in service by the summer of 2012.

The study cases provide a representation of the transmission system as projected by the utilities in the study area for the year, season, and demand condition selected. The Monument–Palmer Lake 115 kV line was represented as closed in the study case. In addition, PSCo has studied the future replacement of the MidwayPS–Daniels Park 230 kV line with a MidwayPS–Waterton 345 kV line along with the addition of a 560 MVA 345–230 kV transformer at the MidwayPS Substation and the addition of a 560 MVA 345–230 kV transformer at the Waterton Substation. The study included cases with and without the MidwayPS–Waterton 345 kV line and transformers. The Midway - Waterton 345 kV project as of the date of this report has received a CPCN and the project is going forward with an expected in service date of June 2011.

The request was studied as both a Network Resource (NR)³, and as an Energy Resource (ER)⁴. The project costs to install the transmission interconnection facilities (ER & NR) and transmission system infrastructure (NR) upgrades necessary to accommodate the added Customer generation have been evaluated by Engineering with the details of these upgrades identified in Section G.

The engineering evaluation determined that from the time of the Authorization to proceed until the In–Service Date⁵ for back–feed would be approximately 20 months. PSCo Engineering has indicated that replacing the Comanche 230–115 kV transformers (required for network service) should be complete by summer of 2010.

The wind farm site would be located in the San Isabel Electric Association service territory and not in the PSCo retail service territory. San Isabel Electric Association is a rural electric cooperative and a Tri-State G&T member. If the Customer chooses to obtain the house power requirements for the site from San Isabel Electric Association, the Customer will need to coordinate this with San Isabel Electric Association.

The construction work required to interconnect at the Comanche 345 kV yard for back–feed would consist of the following:

- Construct an additional line position in the Comanche 345 kV bus. (PSCo–funded costs)

³ **Network Resource Interconnection Service** shall mean an Interconnection Service that allows the Interconnection Customer to integrate its Large Generating Facility with the Transmission Provider's Transmission System (1) in a manner comparable to that in which the Transmission Provider integrates its generation facilities to serve native load customers; or (2) in an RTO or ISO with market-based congestion management, in the same manner as all other Network Resources. Network Resource Interconnection Service in and of itself does not convey transmission service.

⁴ **Energy Resource Interconnection Service** (ER Interconnection Service) shall mean an Interconnection Service that allows the Interconnection Customer to connect its Generating Facility to the Transmission Provider's Transmission System to be eligible to deliver the Generating Facility's electric output using the existing firm or non-firm capacity of the Transmission Provider's Transmission System on an as-available basis. Energy Resource Interconnection Service in and of itself does not convey transmission service.

⁵ **In-Service Date** shall mean the date upon which the Interconnection Customer reasonably expects it will be ready to begin use of the Transmission Provider's Interconnection Facilities to obtain back-feed power.



- Install revenue-metering equipment including CT/VT metering instrument and line termination equipment at the Comanche transformers, meters, and recorder. (Customer-funded costs)
- Modify the substation associated with the Customer's 345 kV transmission line to Comanche. (Customer-funded costs)

The estimated project cost is: \$5.37 million

The costs for the transmission interconnection required for back-feed are scoping level cost estimates (+/- 30%) in 2009 dollars (no escalation applied) and are based upon typical construction costs for previously performed similar construction.

The network upgrades required for delivery of the 300 MW output of the Wind facility would consist of the following:

- Upgrade the two Comanche 230 – 115 kV transformers to 280 MVA each (PSCo-funded costs).
Project is scheduled to be completed in 2010.
- Upgrade the two Waterton 230 – 115 kV transformers to 280 MVA each (PSCo-funded costs).
Project is scheduled to be completed in 2010.
- Upgrade the terminals at Walsenburg in the Comanche – Walsenburg 230 kV line to 239 MVA
- Upgrade the Prairie – Greenwood 230 kV line (PSCo-funded costs)
- Upgrade the Comanche – Reader 115 kV line (PSCo-funded costs)

The transmission facility enhancements listed above will be completed through the PSCo Capital Budget Construction Process.



B. Stand-Alone Study Results

The stand-alone results are based upon comparative studies with the new Customer wind generation project interconnecting at the Comanche Substation 345 kV bus, with the Customer generation modeled in the power flow case either at a full output of approximately 300 MW or offline at 0 MW output. The remaining PSCo Balancing Authority (Area 70) generation and loads in the power flow model reflect a 2012 heavy summer load with heavy south-to-north stressed flows. For further details, refer to the Power Flow Study Models section below.

The studies identify that the Customer can provide the full 300 MW generation addition once some modifications have been completed to the transmission system infrastructure. The overloaded transmission elements that have been identified by these studies as being influenced by the delivery of the added generation occur on both the PSCo and neighboring utilities (Black Hills Power) 230 kV and 115 kV systems in the immediate region electrically near the Comanche POI. Therefore, as it pertains to this feasibility study, the ER and NR capabilities are as follows:

- **Energy Resource (ER) Injection capability: 0 MW**

Energy Resource Interconnection Service is an Interconnection Service that allows the Interconnection Customer to connect its Generating Facility to the Transmission Provider's Transmission System to be eligible to deliver the Generating Facility's electric output using the existing firm or non-firm capacity of the Transmission Provider's Transmission System on an as available basis. Energy Resource Interconnection Service in and of itself does not convey transmission service.

Due to existing overloads and firm transmission commitments, the ER portion of this study determined that the Customer could provide 0 MW of firm injection at the POI without construction of network reinforcements. Non-firm transmission capability may be available depending on marketing activities, dispatch patterns, generation levels, demand levels, import path levels (TOT3, etc.) and the operational status of transmission facilities.

- **Network Resource (NR) injection capability = 300 MW after the network upgrades are completed.**

Network Resource Interconnection Service is an Interconnection Service that allows the Interconnection Customer to integrate its Large Generating Facility with the Transmission Provider's Transmission System in a manner comparable to that in which the Transmission Provider integrates its generating facilities to serve native load customers. A Network Resource is any designated generating resource owned, purchased, or leased by a Network Customer under the Network Integration Transmission Service Tariff. Network Resources do not include any resource, or any portion thereof, that is committed for sale to third parties or otherwise cannot be called upon to meet the Network Customer's Network Load on a non-interruptible basis. Network Resource Interconnection Service in and of itself does not convey transmission service.



The Feasibility Study determined that the NR Injection capability is 300 MW after network upgrades are completed. Network upgrades are additions, modifications, and upgrades to the Transmission Provider's Transmission System required at or beyond the point at which the Interconnection Facilities connect to the Transmission Provider's Transmission System to accommodate the interconnection of the Large Generating Facility to the Transmission Provider's Transmission System.

- **Reactive Power Capability**

The power flow models were also utilized to determine the Customer's reactive power generation capacities that may be necessary to meet the reactive power requirements at the Comanche 345 kV POI. The wind farm was modeled operating at 0.91 lagging (absorbing) power factor with an associated capacitor bank at the end of the 34.5 kV collector system to provide voltage support. The VAR output from the capacitor bank was adjusted to establish a 0.95 lagging, unity, and 0.95 leading power factor at the POI. Surrounding buses and generators were monitored in order to observe the effect of the wind farm's net reactive power output.

With the generation off-line and the transmission line energized, 35 MVAR is introduced into the bulk transmission system and the POI. To operate at ± 0.98 power factor while off-line, a reactor must be installed to reduce the reactive power at the POI.

This model did not include any of the Customer's wind farm 34.5 kV collector feeders and cables, so the capacitive contribution of this 34.5 kV network has not been determined in this study. A more detailed investigation will be conducted in the System Impact Study. It is the responsibility of the Customer to determine what type of equipment is required (CVAR, switched capacitors, SVC, reactors, etc.), the final ratings (MVAR, voltage), and the location (project substation or Comanche POI) that will be necessary to meet the reactive power controllability requirements.

The Interconnection Customer's Interconnection Facilities costs are to be determined by the Customer. These include all facilities and equipment, as identified in the Standard Large Generator Interconnection Agreement, which are located between the Generating Facility and the Point of Change of Ownership, including any modifications, additions, or upgrades to such facilities and equipment necessary to physically and electrically interconnect the Generating Facility to the Transmission Provider's Transmission System. The Interconnection Customer's Interconnection Facilities are sole use facilities.



The Interconnection Agreement (IA) requires that certain conditions be met, as follows:

1. The conditions of the Large Generator Interconnection Guidelines (LGIG) must be met.
2. PSCo will require testing of the full range of 0 MW to 300 MW operational capability of the facility. These tests will include, but not be limited to, power factor control, and VAR control as measured at the Comanche 345 kV bus POI for various generation output levels (0 to 300 MW) of the Customer's wind generation facility.
3. A single point of contact needs to be provided to PSCo Operations to manage the transmission system reliably for all wind projects on the proposed line.

Figure 1: Transmission System Overview in Project Region

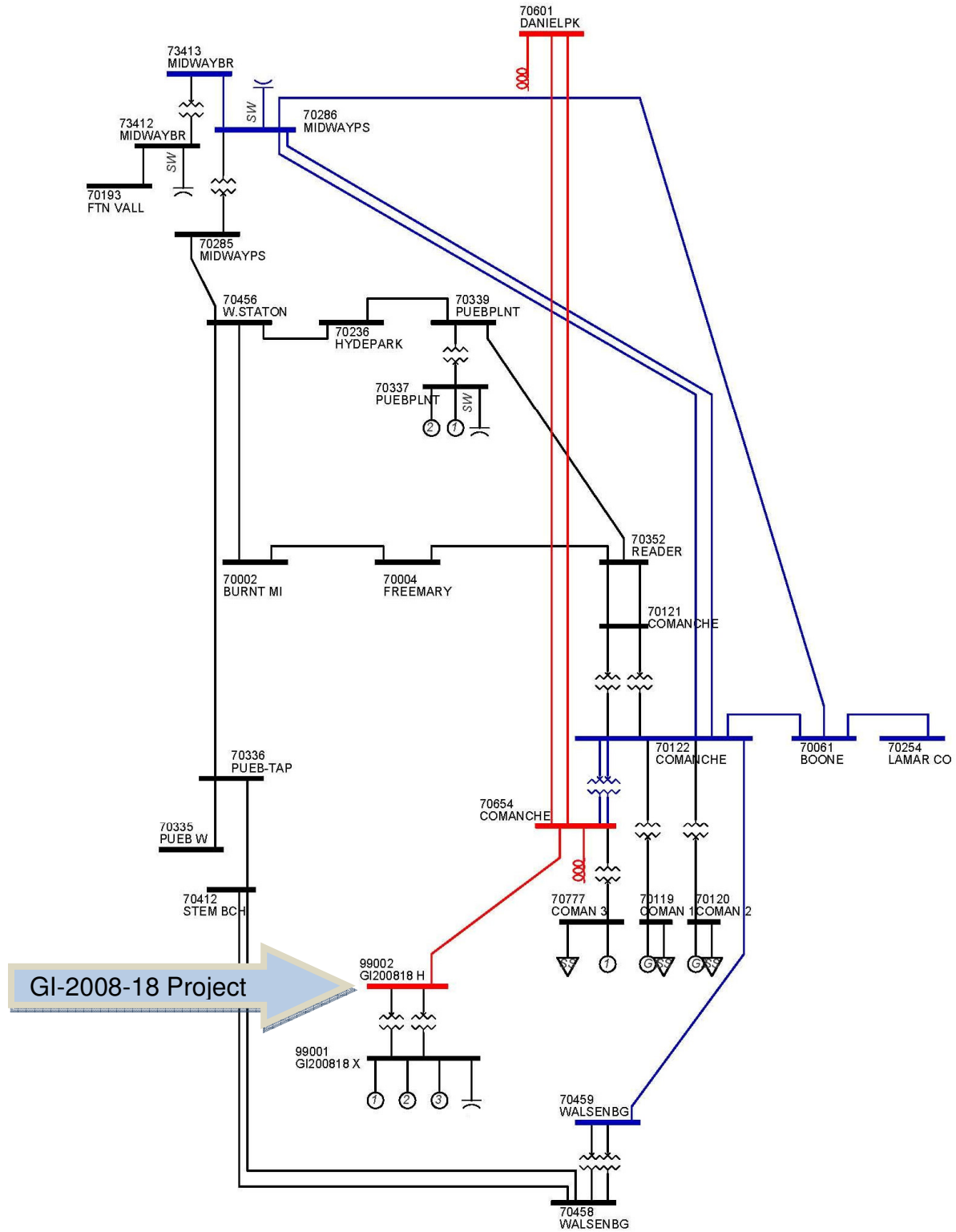



C. Introduction

The Interconnection Feasibility Study evaluated the transmission impacts associated with the proposed interconnection of 300 MW of new Customer generation into the PSCo Transmission System at the Comanche Substation 345 kV bus. The Customer's proposed new 300 MW wind project would be located approximately 15 miles east of Walsenburg, Colorado. The Customer's new interconnecting 345 kV transmission line would be constructed for 50 miles in a typical horizontal configuration on lattice-type structures using Drake (795 kcmil ASCR) conductor per phase. The Comanche 345 kV Point of Interconnection (POI) was the only interconnection point studied.

D. Study Scope and Analysis

This study consisted of steady-state power flow analysis and short circuit analysis. The power flow analysis provided a preliminary identification of any thermal or voltage violations resulting from the interconnection, and for a NR request, a preliminary identification of network upgrades required to deliver the proposed generation to PSCo loads. PSCo adheres to NERC/WECC Reliability Criteria as well as internal Company criteria for planning studies. During system intact conditions, criteria are to maintain transmission system bus voltages between 0.95 and 1.05 per-unit of nominal/normal conditions, and steady state power flows within 1.0 per-unit of all elements' thermal (continuous current or MVA) ratings. Operationally, PSCo maintains a transmission system voltage profile ranging from 1.02 per-unit or higher at generation buses to 1.0 per-unit or higher at transmission load buses. Following a single-contingency element outage, transmission system steady state bus voltages must remain within 0.90 per-unit to 1.10 per-unit and power flows within 1.0 per-unit of the elements' continuous thermal ratings.

Interconnecting to the PSCo bulk transmission system involves the Customer adhering to certain interconnection requirements. These requirements are contained in the Interconnection Guidelines for Transmission Interconnected Producer-Owned Generation Greater than 20 MW (Guidelines). The guidelines refer to interconnection requirements from FERC Order 661A. FERC Order 661A describes the interconnection requirements for wind generation plants. In addition, PSCo System Operations conducts commissioning tests prior to the commercial in-service date for a Customer's facilities. Some of the requirements that the Customer must complete include the following:

1. A wind generating plant shall maintain a power factor within the range of 0.95 leading to 0.95 lagging, measured at the POI, if the Transmission Provider's Study shows that such a requirement is necessary to ensure safety or reliability.
2. The Feasibility Study will investigate pertinent demand, dispatch, and outage scenarios based on the defined study area that includes the proposed POI. The study will conform to the NERC Transmission System Planning Performance Requirements (TPL standards)
3. Reactive Power Control at the POI is the responsibility of the Customer. Additional Customer studies should be conducted by the Customer to ensure that the facilities can meet the power factor control test and the voltage controller test when the facility is undergoing commission testing.



4. PSCo System Operations will require the Customer to perform operational tests prior to commercial operation that would verify that the equipment installed by the Customer meets operational requirements.
5. The Customer is responsible for engineering, permitting, and financing their transmission facilities up to the POI to PSCo.

For this project, possible affected parties include Black Hills Power (service territory formerly the responsibility of Aquila, Inc.), Tri-State G&T, and Colorado Springs Utilities (CSU). These parties will be contacted for involvement in the transmission overloads identified in this study, and possible new projects that may be required as a result of this interconnection.

E. Power Flow Study Models

The power flow studies used PSCo's 2012 Heavy Summer (HS) Budget Case, which is based on the WECC 2012 Heavy Summer approved operating case. The PSCo case was modified to include some corrections and additions that were not already included in the WECC case model. The cases were modeled with and without the Midway – Waterton 345 kV line in service. In addition, CSU loads, switched shunts, and branch impedances were modified to create a more accurate model of the CSU system. The Comanche–Daniels Park 345 kV line was included and has been placed in service in 2009. Two 40 MVAR reactors were also installed at Comanche and Daniels Park. Future projects that were not modeled include the Pawnee–Smoky Hills 345 kV line and the new generation at Lamar (Lamar Energy Center) as well as the associated 500 kV system.

The generation in the PSCo Balancing Authority (Area 70) was dispatched for heavy south–to–north stressing, with the PSCo swing bus moved to Cherokee #3 and generation levels in the south increased to maximum levels. Generation in the north was correspondingly decreased, and Western–RMR Balancing Authority (Area 73) to PSCo interchange was increased by 130 MW. The existing Comanche generators were set to regulate voltage at 1.04 per–unit at the Comanche 230 kV bus in order to stress the amount of reactive power flowing in the Comanche plant.

F. Power Flow Study Process

Two power flow generation dispatch scenarios were evaluated. A reference dispatch model was established without the Customer's 300 MW generation to provide a baseline point of comparison ("Base Case"). A second model included the Customer's 300 MW generation ("Gen Case") and was used to analyze power flow variations within the system because of the added generation. Additional power flow cases were analyzed with and without the Midway–Waterton 345 kV line, which is scheduled to be in service in 2011. A second set of cases for a 2011 light winter were also studied to determine VAR requirements at the POI.



The Customer’s generation was dispatched in the Gen Case by lowering other PSCo generation by 300 MW in the north. Imports from Western–RMR (Area 73) were held constant. Reductions were made at locations that would maintain or maximize the south–to–north stressing in the case. The generation schedules of the Base Case and Gen Case are shown in Table 1.

Table 1: HS Case Generation Schedules

Station / Interface	Base Case (MW)	Gen Case (MW)
Pawnee	505	395
Manchief	65	65
Brush	0	0
Ft. Lupton	265	265
Ft. St. Vrain	450	450
Comanche	1,475	1,475
Ftn. Valley	240	240
Lamar DC (E–W)	210	210
Twin Buttes	9.4	9.4
CO Green	20	20
Peetz–Logan	50	50
Sidney DC (E–W)	120	120
Stegall DC (E–W)	80	80
Laramie River (MBPP)	1,135	1,135
Valmont	200	200
Spruce	240	160
RMEC	240	180
Cherokee	220	170
Rawhide	290	290
WY – CO (TOT3)	1,300	1,309

Per the Customer’s Interconnection Feasibility Study Agreement the wind farm will consist of 182 Vestas V82-1.65 MW wind turbine generators. An associated collector system will bring power back to the project substation where it will be stepped up to 345 kV. The Customer’s facility was modeled as three 100.1 MW lumped–equivalent generators with two 34.5 – 345 kV GSU transformers. The three equivalent generators were each modeled with a maximum capacity of 100.1 MW and a reactive power consumption of 44.9 MVAR based on the reactive power capability of the Vestas V82 generators. The total injected power, at full output, is 329 MVA with a 0.91 leading (absorbing) pf at the Customer’s 34.5 kV bus.

Due to the large amount of reactive power consumed by the wind turbine generators the model assumed the installation of a 140 MVAR capacitor bank on the wind farm’s 34.5 kV collector bus, per the preliminary one-line provided by the Customer. This discretionary assumption minimized the amount of reactive power supplied by PSCo and established VAR neutrality at the 345 kV Comanche POI.



Data provided by the Customer called for two 34.5 – 345 kV, 87/115/145 MVA transformers operating in parallel at the project substation. The impedance of each transformer was specified as 8% with an X/R ratio of 10. The total 290 MVA capability of these transformers is below the maximum wind farm output of 329 MVA. Therefore, the two transformers in the model were scaled up to a 105/140/175 MVA rating each with the voltage and impedance data remaining the same. Under this assumption the two transformers are large enough to carry the full output of the wind farm when both of them are in service. However, if one transformer is out of service the output of the wind farm would need to be reduced, or larger transformers should be selected. It is the Customer's responsibility to decide the actual characteristics of the transformers.

The wind farm was modeled as connecting into the PSCo 345 kV transmission system via a Customer-owned and constructed 50 mile, 345 kV transmission line. Conductor data provided by the Customer specified 795 kcmil ACSR with a line impedance of $0.1288 + j0.7836 \Omega/\text{mi}$. Shunt susceptance was calculated assuming a typical horizontal configuration on lattice-type structures using Drake (795 kcmil ACSR) conductor per phase. It is the Customer's responsibility to select the appropriate 345 kV line parameters to the POI.

G. Power Flow Study Results and Conclusions

Automated contingency power flow studies were completed on both case models using Siemens PTI's PSS/E program, switching out single elements one at a time for all of the elements (lines and transformers) in Area 70 and Area 73. Upon switching each element out, the program resolves with all voltage taps and switched shunt devices locked, and control area interchange adjustments disabled. Automated contingency studies were performed for both the Base Case and the Gen Case models and with the Midway – Waterton 345 kV line in and out of service. The resulting overloaded elements (load flows in excess of their continuous rating) are listed in Table 2 and Table 3 for the Midway – Waterton line in service and out of service, respectively. The tables list overloaded elements that are caused by the addition of the Project, or made worse by more than 5%. The transmission facilities highlighted in Table 2 and Table 3 are on Black Hills Power's system. The percent loading is calculated in terms of the model rating, not the FAC-009⁶ rating.

⁶ "FAC-009" is the Substation/Transmission Facility Equipment Ratings FAC-009 Listing that PSCo maintains for its transmission facilities.



Table 2: Summary of overloaded elements, Midway – Waterton line in service

From	Branch	To	Model Rating (MVA)	FAC-009* Rating (MVA)	Base Case (%)	Gen Case (%)**	Diff. (%)	Contingency
70122	COMANCHE 230	70459 WALSENBG 230 1	159	239	128.5%	134.0%	5.5%	None (N-0)
70004	FREEMARY 115	70352 READER 115 1	100	ukn	96.8%	107.9%	11.1%	Hyde Park 115 kV - Pueblo Plant 115 kV CKT 1
70121	COMANCHE 115	70122 COMANCHE 230 A1	176	176	119.8%	130.9%	11.1%	Comanche 115 kV - Comanche 230 kV CKT A2
70121	COMANCHE 115	70122 COMANCHE 230 A2	184	185	114.9%	125.5%	10.6%	Comanche 115 kV - Comanche 230 kV CKT A1
70121	COMANCHE 115	70352 READER 115 1	239	218	101.2%	111.4%	10.2%	Comanche 115 kV - Reader 115 kV CKT 2
70121	COMANCHE 115	70352 READER 115 2	239	218	101.2%	111.4%	10.2%	Comanche 115 kV - Reader 115 kV CKT 1
70212	GREENWD 230	70323 PRAIRIE2 230 1	275	478	130.9%	158.7%	27.8%	Daniels Park 230kV - Prairie 230 kV CKT 1
70212	GREENWD 230	70331 PRAIRIE 230 1	275	478	93.4%	121.8%	28.4%	Daniels Park 230 kV - Prairie2 230 kV CKT 1
70236	HYDEPARK 115	70339 PUEBPLNT 115 1	105	ukn	141.2%	153.7%	12.5%	Comanche 230 kV - Walsenburg 230 kV CKT 1
70236	HYDEPARK 115	70456 W.STATON 115 1	105	ukn	125.4%	137.9%	12.5%	Comanche 230 kV - Walsenburg 230 kV CKT 1
70330	PORTLAND 115	70456 W.STATON 115 1	80	ukn	95.6%	105.6%	10.0%	MidwayBR 230 kV - West Canon 230 kV CKT 1
70336	PUEB-TAP 115	70412 STEM BCH 115 1	77	ukn	258.4%	264.5%	6.1%	Comanche 230 kV - Walsenburg 230 kV CKT 1
70336	PUEB-TAP 115	70456 W.STATON 115 1	95	ukn	263.5%	268.7%	5.2%	Comanche 230 kV - Walsenburg 230 kV CKT 1
70339	PUEBPLNT 115	70352 READER 115 1	159	ukn	92.8%	101.1%	8.3%	Comanche 230 kV - Walsenburg 230 kV CKT 1
70463	WATERTON 115	70464 WATERTON 230 T1	100	100	119.9%	125.5%	5.6%	Waterton 115 - Waterton 230 kV CKT T2
70463	WATERTON 115	70464 WATERTON 230 T2	100	100	121.0%	126.6%	5.6%	Waterton 115 - Waterton 230 kV CKT T1

*FAC-009 Ratings per the Substation/Transmission Facility Equipment Ratings FAC-009, Revision 8, Dated June 12, 2009

**Generation Case assumes a 130 MVAR capacitor bank on the 34.5 kV collector bus

Items highlighted are on Black Hills Power's system.



Table 3: Summary overloaded elements, Midway – Waterton line out of service

From	Branch	To	Model Rating (MVA)	FAC-009* Rating (MVA)	Base Case (%)	Gen Case (%)**	Diff (%)	Contingency
70122	COMANCHE 230	70459 WALSENBG 230 1	159	239	128.8%	134.4%	5.6%	None (N-0)
70004	FREEMARY 115	70352 READER 115 1	100	ukn	94.1%	104.8%	10.7%	Hyde Park 115 kV - Pueblo Plant 115 kV CKT 1
70121	COMANCHE 115	70122 COMANCHE 230 A1	176	176	116.6%	127.2%	10.6%	Comanche 115 kV - Comanche 230 kV CKT A2
70121	COMANCHE 115	70122 COMANCHE 230 A2	184	185	111.8%	122.0%	10.2%	Comanche 115 kV - Comanche 230 kV CKT A1
70121	COMANCHE 115	70352 READER 115 1	239	218	98.1%	107.8%	9.7%	Comanche 115 kV - Reader 115 kV CKT 2
70121	COMANCHE 115	70352 READER 115 2	239	218	98.1%	107.8%	9.7%	Comanche 115 kV - Reader 115 kV CKT 1
70212	GREENWD 230	70323 PRAIRIE2 230 1	275	478	130.4%	158.4%	28.0%	Daniels Park 230kV - Prairie 230 kV CKT 1
70212	GREENWD 230	70331 PRAIRIE 230 1	275	478	93.6%	122.1%	28.5%	Daniels Park 230 kV - Prairie2 230 kV CKT 1
70236	HYDEPARK 115	70339 PUEBPLNT 115 1	105	ukn	139.1%	151.4%	12.3%	Comanche 230 kV - Walsenburg 230 kV CKT 1
70236	HYDEPARK 115	70456 W.STATON 115 1	105	ukn	123.3%	135.5%	12.2%	Comanche 230 kV - Walsenburg 230 kV CKT 1
70330	PORTLAND 115	70456 W.STATON 115 1	80	ukn	102.0%	113.0%	11.0%	MidwayBR 230 kV - West Canon 230 kV CKT 1
70336	PUEB-TAP 115	70412 STEM BCH 115 1	77	ukn	261.6%	268.3%	6.7%	Comanche 230 kV - Walsenburg 230 kV CKT 1
70336	PUEB-TAP 115	70456 W.STATON 115 1	95	ukn	266.3%	272.0%	5.7%	Comanche 230 kV - Walsenburg 230 kV CKT 1
73409	KELKER W 115	73420 ROCKISLD 115 1	142	ukn	99.4%	102.3%	2.9%	Kelker East 115 kV - Templeton 115 CKT 1

*FAC-009 Ratings per the Substation/Transmission Facility Equipment Ratings FAC-009, Revision 8, Dated June 12, 2009

**Generation Case assumes a 130 MVAR capacitor bank on the 34.5 kV collector bus

Items highlighted are on Black Hills Power's system.



The studies indicated that the additional 300 MW of Customer injection into the Comanche 345 kV bus POI could cause new and/or additional flows in excess of present or planned element ratings. There were four new voltage violations as a result of added generation. The following is a list of overloaded transmission facilities and over-voltage violations on the PSCo system that are due to or made worse by the proposed 300 MW generating facility.

- Comanche 115 – 230 kV Autotransformers: During the loss of one of the two 115 – 230 kV autotransformers at Comanche, the other transformer becomes overloaded. These overloads occur in the Base Case but are worsened between 10 to 11% in the Gen Case with both the Midway–Waterton line in service and out of service. This issue can be resolved by completion of planned upgrades of the autotransformers to units with 280 MVA ratings. The upgrades are planned to be completed by summer 2010.
- Prairie – Greenwood 230 kV: For N-1 conditions, during the loss of one of the two Daniels Park – Prairie lines, the other Prairie – Greenwood 230 kV line overloads. This contingency overload occurs in the Base Case but is worsened by 28 to 29% in the Gen Case with both the Midway – Waterton line in service and out of service. The issue is resolved with the updated FAC-009 ratings of 478 MVA for the line traps at Greenwood.
- Comanche – Walsenburg 230 kV: During system–intact conditions, the Comanche – Walsenburg 230 kV line is overloaded. The Base Case loading is 129% and increases to 134% in the Gen Case with both the Midway – Waterton line in service and out of service. The issue is resolved with the updated FAC-009 ratings of 239 MVA for the metering unit CTs at Comanche. Tri-State G&T owns and operates the Walsenburg Substation which has a 230 kV terminal limit of 159 MVA. Future planned upgrades to the Walsenburg Substation have yet to be determined, but upgrading this limiting element to 239 MVA will be required.
- Comanche – Reader 115 kV: For N-1 conditions, during the loss of one of the two Comanche – Reader 115 kV lines, the other Comanche – Reader line overloads. This contingency overload occurs in the Base Case but is worsened by 10% in the Gen Case with both the Midway – Waterton line in service and out of service. The issue is resolved with upgrading the existing line terminations to 359 MVA in conjunction with the construction of the second Comanche – Reader 115 kV line, which is scheduled to be completed in 2010.
- Waterton 115 – 230 kV Autotransformers: During the loss of one of the two 115 – 230 kV autotransformers at Waterton, the other transformer becomes overloaded. These overloads occur in the Base Case but are worsened by 6% in the Gen Case with the Midway – Waterton line in service. This issue is resolved with the upgrade of the transformers to 280 MVA, which is scheduled to be completed in May 2011.
- 70119 Comanche 24 kV: During system-intact conditions, the Comanche bus increases above the maximum allowable voltage level. The Base Case bus voltage of 1.046 increases to 1.051 in the Gen Case. This over-voltage only occurs if the Midway – Waterton line out of service. This over-voltage is a result of modeling the existing



Comanche generators to regulate the Comanche 230 kV bus at 1.04 per-unit and does not occur under actual operation.

The following lines on the Black Hills Power systems show overloads for N-1 contingency conditions in both the Base Case and the Gen Case with more than 5% additional overload and/or exceeding 100% max rating in the Gen Case:

- Pueblo Tap – Stem Beach 115 kV (6 – 7% additional overload)
- Pueblo Tap – West Station 115 kV (5 – 6% additional overload)
- Hyde Park – Pueblo 115 kV (12 – 13% additional overload)
- Hyde Park – West Station 115 kV (12 – 13% additional overload)
- Freemary – Reader 115 kV (11% additional overload)
- Portland – West Station 115 kV (10 – 11% additional overload)
- Pueblo – Reader 115 kV (From 93% Base Case to 101% Gen Case, Midway – Waterton in service only)

The following buses in the Tri-State system show under-voltages for N-1 contingency conditions that drop below 0.90 per-unit in the Gen Case:

- 70068 Burro Canyon 115 kV: For N-1 conditions during the loss of the Comanche – Walsenburg 230 kV line, the Burro Canyon bus drops below the minimum allowable voltage level. The Base Case bus voltage of 0.901 per-unit drops to 0.892 per-unit in the Gen Case. This under-voltage only occurs if the Midway – Waterton line is in service.
- 70335 Pueblo West 115 kV: For N-1 conditions during the loss of the Pueblo Tap – West Station 115 kV line, the Pueblo West bus drops below the minimum allowable voltage level. The Base Case bus voltage of 0.902 per-unit drops to 0.898 per-unit in the Gen Case when the Midway – Waterton line is in service. The Base Case bus voltage of 0.901 per-unit drops to 0.897 per-unit in the Gen Case when the Midway – Waterton line is out of service.

Future plans on the Black Hills Power, Tri-State G&T, and Colorado Springs Utilities systems are yet to be determined, so it is possible that planned future upgrades will resolve these overloads and under-voltages. It is also possible that additional upgrades will be necessary. These overloads and under-voltages will be addressed in conjunction with Black Hills Power, Tri-State G&T, and CSU in more detail in the System Impact Study.



Energy Resource (ER):

Due to existing overloads and firm transmission commitments, the ER portion of this study determined that the Customer could provide 0 MW of firm injection at the POI without construction of network reinforcements. Non-firm transmission capability may be available depending on marketing activities, dispatch patterns, generation levels, demand levels, import path levels (TOT3, etc.) and the operational status of transmission facilities.

ER Injection capability: 0 MW

Network Resource (NR):

Table 2 and Table 3 list the lines and auto-transformers that either incur new single-contingency (N-1) overloading or that become significantly overloaded as a result of adding 300 MW of generation at the Comanche 345 kV bus POI. These results are for a power flow model for heavy summer 2012 system conditions, with the case re-dispatched for the maximum generation at Comanche and heavy south-to-north flows. Branch ratings that are expected to change as listed in the FAC-9 Facility Equipment Ratings (Rev. 8) are listed in the table.

NR Injection capability: 300 MW

H. Voltage Control at the Point of Interconnection

The power flow models were also utilized to determine the Customer's reactive power (VAR) generation capacities that may be necessary to meet the operational power factor and related VAR requirements at the Comanche 345 kV POI. Note that a simplified model was used for the Customer wind farm and that detailed models of the Customer's 34.5 kV collector and feeder systems and their associated reactive and capacitive characteristics have not been developed at this stage. The Customer will need to provide more detailed data for further/future studies (e.g. dynamic System Impact Study, detailed Facilities Study) in order to ascertain the specific dynamic VAR capacitive and inductive equipment (DVAR, CVAR, SVC, reactors, etc.) that would be required to meet the VAR requirements.

Heavy Summer (HS) VAR Study:

Several generation scenarios were studied to identify the reactive power and voltage regulation capabilities of the Project. The existing Comanche generators were set to regulate voltage at 1.04 per-unit at the Comanche 230 kV bus. The wind farm's voltage supporting capacitor bank was set to provide a unity power factor at the POI. Next, the capacitor bank was adjusted to demonstrate the effects of ± 10 MVAR reactive power at the POI. Reactive power flow and voltage at the POI, Comanche generators, and the regulated bus were recorded. The results of the analysis are presented in Table 4.



Table 4: 2012 HS ±10 MVAR Reactive Power Effects on Comanche Generators

Bus Name	Basecase				-10 MVAR at POI				Unity PF at POI				+10 MVAR at POI			
	P MW	Q MVAR	pf*	V pu	P MW	Q MVAR	pf*	V pu	P MW	Q MVAR	pf*	V pu	P MW	Q MVAR	pf*	V pu
Windfarm Gen 34.5 kV	N/A	N/A	N/A N/A	N/A	300.3	-134.7	0.91 (-)	1.06	300.3	-134.7	0.91 (-)	1.07	300.3	-134.7	0.91 (-)	1.07
Windfarm Gen 345 kV (POI)	N/A	N/A	N/A N/A	1.04	292.9	-10.0	1.00 (-)	1.04	293.0	0.0	1.00 U	1.04	293.0	10.0	1.00 (+)	1.04
Comanche 1 24 kV	360.0	92.0	0.97 (+)	1.03	360.0	103.9	0.96 (+)	1.03	360.0	101.5	0.96 (+)	1.03	360.0	99.1	0.96 (+)	1.03
Comanche 2 24 kV	365.0	92.0	0.97 (+)	1.03	365.0	103.9	0.96 (+)	1.03	365.0	101.5	0.96 (+)	1.03	365.0	99.1	0.97 (+)	1.03
Comanche 3 24 kV	750.0	184.0	0.97 (+)	1.06	750.0	207.8	0.96 (+)	1.07	750.0	203.0	0.97 (+)	1.07	750.0	198.2	0.97 (+)	1.06
Comanche 230 kV (Vreg)	N/A	N/A	N/A	1.04	N/A	N/A	N/A	1.04	N/A	N/A	N/A	1.04	N/A	N/A	N/A	1.04
Total Output Comanche	1,475	368.0	N/A	N/A	1,475	415.6	N/A	N/A	1,475	406.0	N/A	N/A	1,475	396.4	N/A	N/A

* (+) denotes a Leading Power Factor (supplying VARs), (-) denotes a Lagging Power Factor (absorbing VARs)

Midway - Waterton line assumed In-Service

Highlighted regions show the project's reactive power flow at the Comanche POI



Table 4 illustrates how reactive power from the 300 MW wind farm affects the Comanche generators. Under these operating scenarios the wind farm has a minimal impact on the reactive power outputs from all three Comanche generators. The Comanche 3 generator bus voltage is 1.06 per-unit or higher, which is above the limit of 1.05 per-unit for regulating buses, according to the Xcel Energy document titled Rocky Mountain Area Voltage Coordination Guidelines. Actual operation of the Comanche 3 generator is to regulate its own bus instead of the Comanche 230 kV bus. Under this condition the over voltage does not occur.

The impact of the wind generating facility on the reactive power schedules of nearby generating units may need to be mitigated by the Customer if system studies demonstrate that the proposed wind generating facility causes nearby generating units to generate or absorb reactive power for voltage control. Sufficient reactive power reserve must be maintained on generating units to allow them to dynamically regulate voltage for extreme system conditions. PSCo will accommodate up to 10 MVAR of reactive power for a wind generating facility. Any additional VAR requirements are the responsibility of the wind generating facility. These models did not include any of the Customer's wind farm 34.5 kV collector feeders and cables, so the capacitive contribution of this 34.5 kV network has not been determined in this study.

The VAR study also analyzed the model under three additional scenarios. First, the model was run to demonstrate the effects of operating the wind farm without a voltage supporting capacitor bank. The second model demonstrated the minimum VAR support needed to establish a 0.95 lagging power factor at the POI. Lastly, the model was run with the project generation at 0 MW output with the project substation to Comanche 345 kV line energized. This was done to determine the approximate MVAR flow from the project substation to the POI at Comanche due to line capacitance. Analyzing a 0.95 leading power factor was not completed due to the unreasonable size of capacitors needed to supply the necessary VARs. Reactive power flow and voltages at the POI, Comanche generators, and the regulated bus were recorded. The results of the analysis is presented in Table 5.



Table 5: 2012 HS Worst Case Reactive Power Effects on Comanche Generators

Bus Name	Basecase				Capacitor Bank Offline				0.95 Lagging at POI				Windfarm Offline			
	P MW	Q MVAR	pf*	V pu	P MW	Q MVAR	pf*	V pu	P MW	Q MVAR	pf*	V pu	P MW	Q MVAR	pf*	V pu
Windfarm Gen 34.5 kV	N/A	N/A	N/A N/A	N/A	300.3	-134.7	0.91 (-)	0.94	300.3	-134.7	0.91 (-)	1.00	0.0	0.0	N/A N/A	1.05
Windfarm Gen 345 kV (POI)	N/A	N/A	N/A N/A	1.04	289.3	-186.9	0.84 (-)	1.03	291.8	-95.9	0.95 (-)	1.04	0.0	35.0	0.00 (+)	1.04
Comanche 1 24 kV	360.0	92.0	0.97 (+)	1.03	360.0	146.9	0.93 (+)	1.04	360.0	124.6	0.94 (+)	1.04	360.0	81.9	0.98 (+)	1.03
Comanche 2 24 kV	365.0	92.0	0.97 (+)	1.03	365.0	146.9	0.93 (+)	1.05	365.0	124.6	0.95 (+)	1.04	365.0	81.9	0.98 (+)	1.03
Comanche 3 24 kV	750.0	184.0	0.97 (+)	1.06	750.0	293.9	0.93 (+)	1.08	750.0	249.3	0.95 (+)	1.08	750.0	163.8	0.98 (+)	1.06
Comanche 230 kV (Vreg)	N/A	N/A	N/A	1.04	N/A	N/A	N/A	1.04	N/A	N/A	N/A	1.04	N/A	N/A	N/A	1.04
Total Output Comanche	1,475	368.0	N/A	N/A	1,475	587.7	N/A	N/A	1,475	498.5	N/A	N/A	1,475	327.6	N/A	N/A

* (+) denotes a Leading Power Factor (supplying VARs), (-) denotes a Lagging Power Factor (absorbing VARs)

Midway - Waterton line assumed In-Service

Highlighted regions show the project's reactive power flow at the Comanche POI



Under the first scenario with the capacitor bank offline, the 135 MVAR consumed by the wind farm translates to 187 MVAR supplied at the POI. Under the second scenario at a 0.95 lagging power factor the VARS supplied at the POI amount to 96 MVAR. Both of these conditions fall outside the 10 MVAR margin PSCo will accommodate and will require the Customer to further evaluate what type of equipment is needed to operate the wind farm at full generation.

Under the last scenario, with the project generation at 0 MW and the bus voltage near 1.04 per-unit at the Comanche 345 kV bus POI, the reactive flow into the POI is approximately 35 MVAR. If a wind generating facility is interconnected to the bulk transmission system but is operating with its generation off-line and receiving power from the bulk transmission system for its station service requirements that facility is acting as a load. PSCo requires a power factor of 0.98 lagging or leading be maintained at the POI (when the station service load is greater than 85% of maximum) per the Xcel Energy document titled Interconnection Guidelines For Transmission Interconnected Customer Loads. This requirement helps ensure that the PSCo transmission system would not be burdened with absorbing unwanted reactive flows and possible high voltages caused by this reactive power under typically light system loading conditions.

Therefore, it appears likely that shunt reactors will be needed to operate within the ± 0.98 pf range requirement⁷. As previously stated, these models did not include any of the Customer's wind farm 34.5 kV collector feeders and cables, so the possible capacitive contribution of this 34.5 kV network has not been determined in this study. The reactive charging of the actual 345 kV line configuration used should also be taken into account in more detailed future studies.

Light Winter (LW) VAR Study:

A light load case was studied to determine how the wind farm would affect the VAR output of the surrounding Comanche generators. The lines in the WECC 2011 Light Winter (LW) case were modified to more closely match the 2012 Heavy Summer case. These modifications include changes to the CSU system, removal of the Pawnee – Smoky Hills 345 kV line, removal of the Stem Beach 115 – 230 kV transformer, and the removal of the Walsenburg – San Louis Valley 230 kV line. Generation schedules were adjusted to create a heavy south to north flow as outlined in Table 6.

⁷ NOTE – It is the responsibility of the Customer to determine what type of equipment is required (CVAR, added switched capacitors, SVC, reactors, etc.) and what final ratings (MVAR, voltage 34.5 kV, 345 kV) and location (project substation or Comanche POI) will be necessary to meet the reactive power controllability requirements. Furthermore, the actual voltage tap ratios used for the Customer's main 34.5 – 345 kV transformers will directly impact the operating voltages and related reactive capabilities for the project facility. The Customer should review these studies in determining the final design requirements for this equipment (CVAR, transformer voltage tap ratios and MVA, etc.).



Table 6: LW Case Generation Schedules

Station / Interface	Base Case (MW)	Gen Case (MW)
Pawnee	400	250
Manchief	0	0
Brush	50	50
Ft. Lupton	0	0
Ft. St. Vrain	0	0
Comanche	1,475	1,475
Ftn. Valley	0	0
Lamar DC (E-W)	210	210
Twin Buttes	9.4	9.4
CO Green	20	20
Peetz-Logan	250	250
Sidney DC (E-W)	-196	-196
Stegall DC (E-W)	60	60
Laramie River (MBPP)	200	200
Valmont	100	100
Spruce	0	0
RMEC	0	0
Cherokee	220	130
Rawhide	150	90
WY – CO (TOT3)	489	505

As was the case in the Heavy Summer VAR study, the existing Comanche generators were set to regulate voltage at 1.04 per-unit at the Comanche 230 kV bus. The capacitor bank in the wind farm model was adjusted to provide a unity power factor at the POI with and a ± 10 MVAR deviation. The three scenarios of no capacitor bank, 0.95 lagging power factor, and generation offline were also modeled. Reactive power flow and voltages at the POI, Comanche generators, and the regulated bus were recorded. The results of this analysis are presented in Table 7 and Table 8.



Table 7: 2011 LW ±10 MVAR Reactive Power Effects on Comanche Generators

Bus Name	Basecase				-10 MVAR at POI				Unity PF at POI				+10 MVAR at POI			
	P MW	Q MVAR	pf*	V pu	P MW	Q MVAR	pf*	V pu	P MW	Q MVAR	pf*	V pu	P MW	Q MVAR	pf*	V pu
Windfarm Gen 34.5 kV	N/A	N/A	N/A N/A	N/A	300.3	-134.7	0.91 (-)	1.06	300.3	-134.7	0.91 (-)	1.07	300.3	-134.7	0.91 (-)	1.07
Windfarm Gen 345 kV (POI)	N/A	N/A	N/A N/A	1.04	292.9	-10.0	1.00 (-)	1.04	293.0	0.0	1.00 U	1.04	293.0	10.0	1.00 (+)	1.04
Comanche 1 24 kV	360.0	86.9	0.97 (+)	1.03	360.0	99.5	0.96 (+)	1.03	360.0	96.0	0.97 (+)	1.03	360.0	94.8	0.97 (+)	1.03
Comanche 2 24 kV	365.0	86.9	0.97 (+)	1.03	365.0	99.5	0.96 (+)	1.03	365.0	96.0	0.97 (+)	1.03	365.0	94.8	0.97 (+)	1.03
Comanche 3 24 kV	750.0	173.8	0.97 (+)	1.06	750.0	199.1	0.97 (+)	1.06	750.0	192.1	0.97 (+)	1.06	750.0	189.5	0.97 (+)	1.06
Comanche 230 kV (Vreg)	N/A	N/A	N/A	1.04	N/A	N/A	N/A	1.04	N/A	N/A	N/A	1.04	N/A	N/A	N/A	1.04
Total Output Comanche	1,475	347.6	N/A	N/A	1,475	398.1	N/A	N/A	1,475	384.1	N/A	N/A	1,475	379.1	N/A	N/A

* (+) denotes a Leading Power Factor (supplying VARs), (-) denotes a Lagging Power Factor (absorbing VARs)

Midway - Waterton line assumed In-Service

Highlighted regions show the project's reactive power flow at the Comanche POI



Table 8: 2011 LW Worst Case Reactive Power Effects on Comanche Generators

Bus Name	Basecase				Capacitor Bank Offline				0.95 Lagging at POI				Windfarm Offline			
	P MW	Q MVAR	pf*	V pu	P MW	Q MVAR	pf*	V pu	P MW	Q MVAR	pf*	V pu	P MW	Q MVAR	pf*	V pu
Windfarm Gen 34.5 kV	N/A	N/A	N/A N/A	N/A	300.3	-134.7	0.91 (-)	0.94	300.3	-134.7	0.91 (-)	1.00	0.0	0.0	N/A N/A	1.05
Windfarm Gen 345 kV (POI)	N/A	N/A	N/A N/A	1.04	289.3	-187.4	0.84 (-)	1.03	291.8	-95.9	0.95 (-)	1.04	0.0	34.9	0.00 (+)	1.04
Comanche 1 24 kV	360.0	86.9	0.97 (+)	1.03	360.0	141.6	0.93 (+)	1.04	360.0	120.2	0.95 (+)	1.04	360.0	77.0	0.98 (+)	1.03
Comanche 2 24 kV	365.0	86.9	0.97 (+)	1.03	365.0	141.6	0.93 (+)	1.04	365.0	120.2	0.95 (+)	1.04	365.0	77.0	0.98 (+)	1.03
Comanche 3 24 kV	750.0	173.8	0.97 (+)	1.06	750.0	283.1	0.94 (+)	1.08	750.0	240.5	0.95 (+)	1.07	750.0	154.0	0.98 (+)	1.05
Comanche 230 kV (Vreg)	N/A	N/A	N/A	1.04	N/A	N/A	N/A	1.04	N/A	N/A	N/A	1.04	N/A	N/A	N/A	1.04
Total Output Comanche	1,475	347.6	N/A	N/A	1,475	566.3	N/A	N/A	1,475	480.9	N/A	N/A	1,475	308.0	N/A	N/A

* (+) denotes a Leading Power Factor (supplying VARs), (-) denotes a Lagging Power Factor (absorbing VARs)

Midway - Waterton line assumed In-Service

Highlighted regions show the project's reactive power flow at the Comanche POI



Table 7 and Table 8 show the effect of the wind farm on the existing Comanche generators during the light load case. The results for the light load case are very similar to the heavy summer case. The voltages and power factors are very close to the heavy load values and the Comanche generators produce approximately 20 MVAR less than the heavy load case. One issue is that the Comanche 3 bus is operating at 1.06 per-unit or higher, which is above the limit of 1.05 per-unit for regulating buses. Actual operation of the Comanche 3 generator is to regulate its own bus instead of the Comanche 230 kV bus. Under this condition the over voltage does not occur. In this LW scenario with the wind farm offline and the transmission line energized, the reactive power flow into the POI is 35 MVAR. These models did not include any of the Customer's wind farm 34.5 kV collector feeders and cables, so the potential capacitive contribution of this 34.5 kV network has not been determined in this study.



I. Short Circuit Study Results

A short circuit study was conducted to determine the fault currents (single-line-to ground or three-phase) at the Comanche Substation 345 kV bus. The study was conducted without the addition of the proposed 300-MW wind farm, as it is not expected to significantly increase the fault currents at the Comanche Substation. Table 9 summarizes the approximate fault currents at the Comanche 345 kV Bus without the addition of the GI-2008-18 facility.

Table 9: Short-Circuit Study Results Without the Proposed 300 MW Wind Farm

System Condition	Three-phase (amps)	Thevenin System Equivalent Impedance (R,X) in ohms	Single-line-to-ground (amps)	Thevenin System Equivalent Impedance (R,X) in ohms
System Intact	$I_1=15063.2$ $I_2=I_0=0.0$ $I_A=I_B=I_C=15063.2$	$Z_1(\text{pos})=$ 0.65620,13.2071 $Z_2(\text{neg})=$ 0.66313,13.2287 $Z_0(\text{zero})=$ 0.48046,8.25350	$I_1=I_2=5734.3$ $3I_0=17202.9$ $I_A=17202.9$ $I_B=I_C=0.0$	$Z_1(\text{pos})=$ 0.65620,13.2071 $Z_2(\text{neg})=$ 0.66313,13.2287 $Z_0(\text{zero})=$ 0.48046,8.25350

The addition of the 300 MW wind farm is not expected to necessitate the replacement of circuit breakers, switches or other substation equipment due to the increased fault current levels at the Comanche Substation.

J. Costs Estimates and Assumptions

Cost estimates of the PSCo-owned/Customer-funded interconnection facilities, the PSCo-owned/PSCo-funded interconnection facilities, and the PSCo network upgrades for delivery were evaluated to determine the approximate cost of these facilities. The results of these evaluations are included below. A conceptual project one-line is included in Figure 2 below for reference.

Figure 2: Conceptual Project One-Line

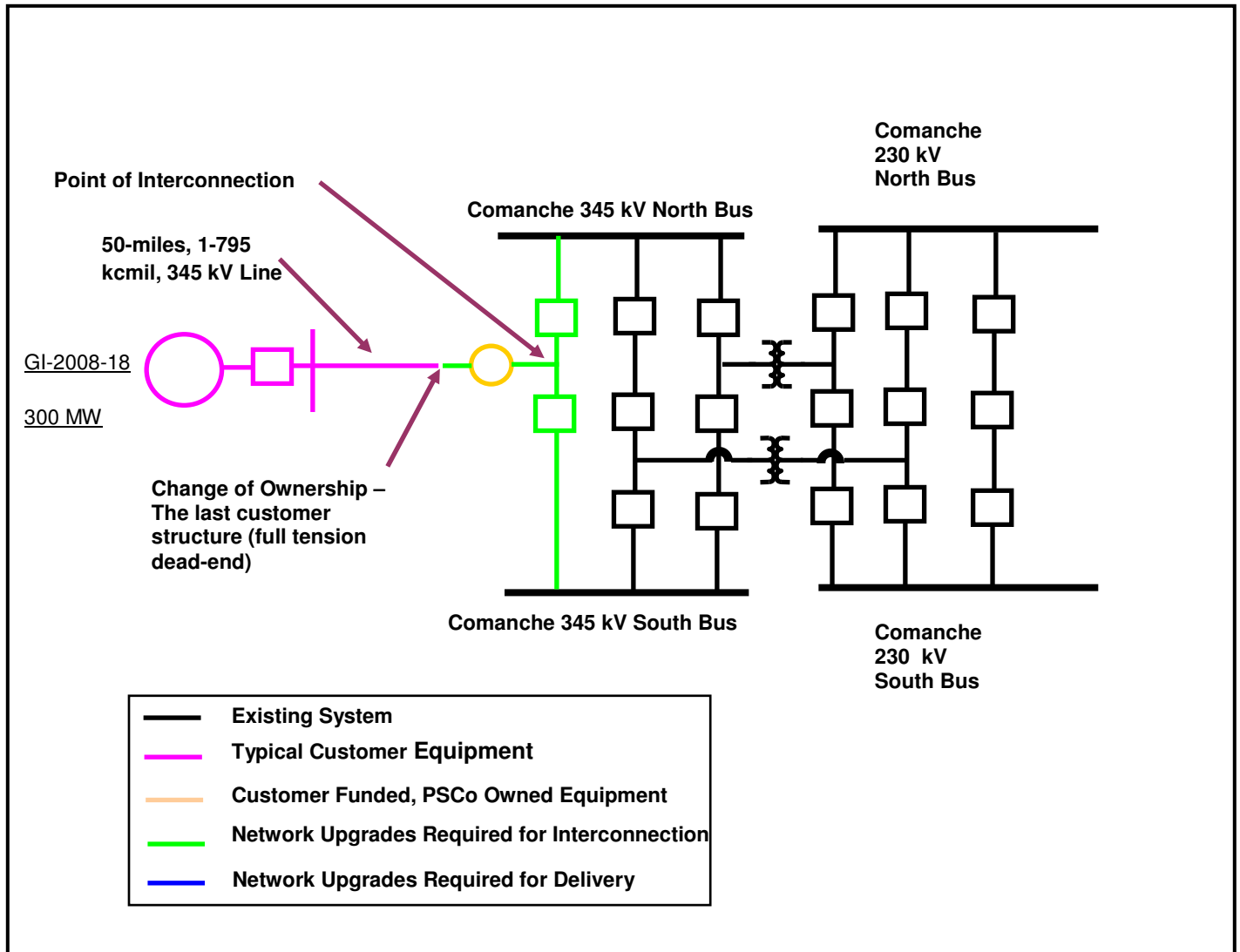



The following tables list the improvements required to accommodate the interconnection and the delivery of the Project generation output. The cost responsibilities associated with these facilities shall be handled as per current FERC guidelines. System improvements are subject to change upon more detailed analysis.

Table 10 – PSCo Owned; Customer Funded Interconnection Facilities

Element	Description	Cost Est. Millions
PSCo's Comanche 345 kV Substation	Interconnect Customer at PSCo's Comanche 345 kV Substation. The new equipment includes revenue metering and associated equipment and material.	\$0.389
	Transmission tie line into substation.	\$1.342
	Customer load frequency/ automatic generation control and Generator Witness Testing.	\$0.010
	Siting and Land Rights for required easements, reports, permits and licenses.	\$0.010
	Total Cost Estimate for PSCo-Owned, Customer-Funded Interconnection Facilities	\$1.751
Time Frame		20 Months

Table 11: PSCo Owned; PSCo Funded Interconnection Facilities

Element	Description	Cost
PSCo's Comanche 345 kV Substation	Interconnect Customer at PSCo's Comanche 345 kV Substation. New 345 kV line termination requiring the following equipment: <ul style="list-style-type: none"> • Three 345 kV breakers • Seven 345 kV gang switches • Electrical bus work • Required steel and foundations • Minor site work (station wiring, grounding) • X- double circuit T-Line structures 	



	Total Cost Estimate for PSCo-Owned, PSCo-Funded Interconnection Facilities	\$3.616
Time Frame		20 Months

Table 12 – PSCo Network Upgrades for Delivery

Element	Description	Cost Est. Millions
PSCo's Transmission Network	Upgrade the two Comanche 230-115 kV transformers to 280 MVA each.	PSCo-funded costs
	Add a Comanche-Reader 115 kV Line #2	PSCo-funded costs
	Upgrade the Daniels Park-Prairie 230 kV line	PSCo-funded costs
	Upgrade the Prairie-Greenwood 230 kV line	PSCo-funded costs
	Replace the MidwayPS-Daniels Park 230 kV line with the MidwayPS-Waterton 345 kV line. Install a 560 MVA 345-230 kV transformer at the MidwayPS Substation and a 560 MVA 345-230 kV transformer at the Waterton Substation.	PSCo-funded costs
	Total Cost Estimate for PSCo Network Upgrades for Delivery	N/A
	Total Cost of Project	\$5.370



Assumptions for Alternatives

- The estimates provided are “scoping estimates” with an accuracy of +/- 30%.
- Estimated dollars include typical escalations for time frame required for design and construction (assumed Fall 2009 to Summer 2011).
- AFUDC is excluded.
- Labor is estimated for straight time only – no overtime included.
- PSCo (or it’s Contractor) crews will perform all construction and wiring associated with PSCo owned and maintained facilities.
- The cost estimates for the PSCo network upgrades for delivery are not included as they are part of PSCo’s Capital Budget Construction process.
- No additional land will be required at the Comanche Substation.
- A 230 kV interconnection was deemed not feasible, so those estimates are not included.
- This estimate and schedule is dependent on other projects at Comanche. If other projects at Comanche at the same time, that could slow down the schedule.
- Lead times for materials were considered for the schedule.
- The transmission line will be required to exit Comanche to the North and will then turn West to exit the Comanche site.
- The Customer transmission line is assumed to be fully compensated per interconnection requirements. Line compensation such as capacitors or line reactors and associated equipment are not included in this estimate and are the responsibility of the Customer.
- The addition of Customer generation will not increase the fault current above the current ratings of existing equipment.

Appendix A: Comanche Station One–Line Diagram Showing Modifications

See following page.

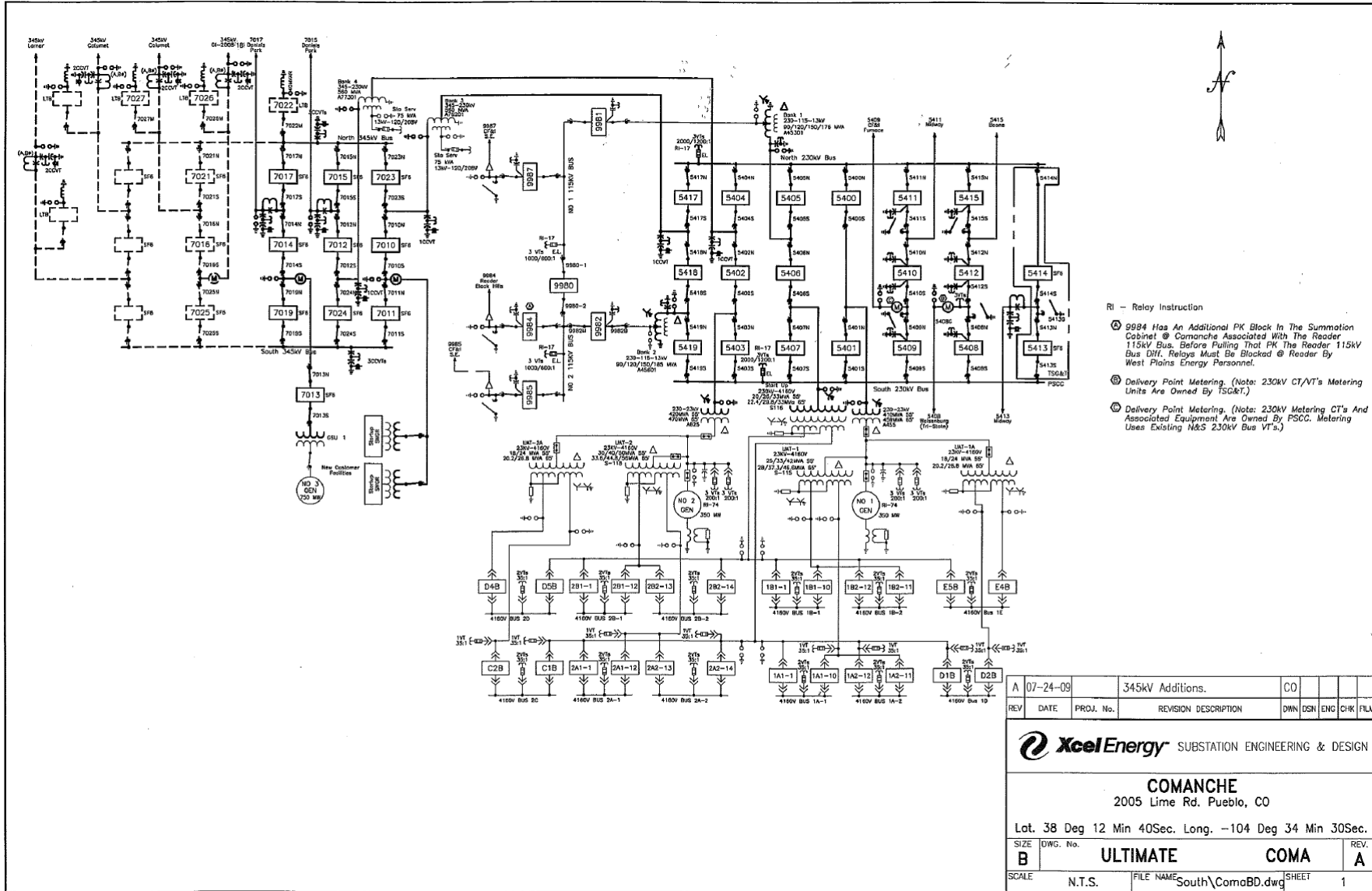

- R1 - Relay Instruction
- Ⓢ 9984 Has An Additional PK Block In The Summation Cabinet @ Comanche Associated With The Reader 115kV Bus Diff. Relays Must Be Blocked @ Reader By West Plains Energy Personnel.
 - Ⓢ Delivery Point Metering. (Note: 230kV CT/VT's Metering Units Are Owned By TSG&T.)
 - Ⓢ Delivery Point Metering. (Note: 230kV Metering CT's And Associated Equipment Are Owned By PSCC. Metering Uses Existing N&S 230kV Bus VT's.)

A	07-24-09	345kV Additions.	CO				
REV	DATE	PROJ. No.	REVISION DESCRIPTION	DWN	DSN	ENG	CHK
SUBSTATION ENGINEERING & DESIGN							
COMANCHE 2005 Lime Rd. Pueblo, CO Lot. 38 Deg 12 Min 40Sec. Long. -104 Deg 34 Min 30Sec.							
SIZE	DWG. No.	ULTIMATE		COMA	REV.		
B					A		
SCALE	N.T.S.	FILE NAME	South\ComaBD.dwg	SHEET	1		