



DRAFT

**GENERATION INTERCONNECTION
REQUEST # GI-2014-13**

**SYSTEM IMPACT STUDY REPORT
53 MW PV SOLAR, ALAMOSA COUNTY, COLORADO**

**XCEL ENERGY – PSCO TRANSMISSION PLANNING WEST
FEBRUARY 2016**

Table of Contents

Executive Summary	3
Introduction.....	9
Study Scope and Analysis.....	9
Reliability Criteria	10
Interconnection Service Categories	11
WECC Base Case Models	11
Interconnection Requirements	12
Power Flow Study Process.....	15
Steady State Power Flow Analysis	16
Study Results Conclusion	17
Voltage Regulation and Reactive Power Capability.....	17
Short Circuit.....	18
Cost Estimate	19
Appendix A - Detailed Steady State Analysis Results	23
Appendix B - Generation Dispatch.....	24



Executive Summary

Public Service Company of Colorado (PSCo) and the Interconnection Customer signed a Generation Interconnection System Impact Study Agreement for 53 MW of solar photovoltaic generation at San Luis Valley (SLV) 230 kV Substation, Colorado. The Interconnection Customer has selected the primary Point of Interconnection (POI) to be at SLV 230 kV bus with no secondary POI. The generating facility (GF) will consist of twenty six (26) 2.2 MVA SMA inverters and will connect to a common 34.5 kV collector bus through two feeder system. Each inverter will have a dedicated 385 V/34.5 kV step-up transformer with an arrangement referred to as a Power Conversion Station (PCS). A single transformer will step the voltage from 34.5 kV to 230 kV for delivery via a 2.9 mile generator tie line.

The proposed Commercial Operation Date (COD¹) is March 1, 2017 with an assumed back feed date of six months prior to COD. This COD may not be feasible based on Engineering's requirement of 18 month construction window from the authorization to proceed.

Figure 1 shows the general area of SLV region. Figure 2 shows the budgeted one-line of the SLV Substation.

This request was for both Energy Resource Interconnection Service (ERIS)² and Network Resource Interconnection Service (NRIS)³. The request was studied as a stand-alone project, with no evaluations made of other potential new generation requests that may exist in the Large Generator Interconnection Procedures (LGIP) queue, other than the generation projects that are

¹ **Commercial Operation Date** of a unit shall mean the date on which the GF commences Commercial Operation as agreed to by the Parties pursuant to Appendix E to the Standard Large Generator Interconnection Agreement.

² **Energy Resource Interconnection Service** shall mean an Interconnection Service that allows the Interconnection Customer to connect its GF to the Transmission Provider's Transmission System to be eligible to deliver the GF's electric output using the existing firm or non-firm capacity of the Transmission Provider's Transmission System on an as available basis. ERIS in and of itself does not convey transmission service

³ **Network Resource Interconnection Service** shall mean an Interconnection Service that allows the Interconnection Customer to integrate its Large GF with the Transmission Provider's Transmission System (1) in a manner comparable to that in which the Transmission Provider integrates its generating facilities to serve native load customers; or (2) in an RTO or ISO with market based congestion management, in the same manner as all other Network Resources. NRIS in and of itself does not convey transmission service nor automatically becomes a Designated Network Resource (DNR).

approved and planned by PSCo to be in service by the end of 2016. The scope of the System Impact Study (SIS) includes a re-evaluation of the Feasibility Study, dynamic stability analysis, short-circuit analysis, and scoping level cost estimate. PSCo has chosen not to identify any network upgrades for delivery to mitigate any thermal violations to avoid confusion because there is an ongoing joint transmission study effort between PSCo and Tri-State Generation and Transmission (TSGT) for the SLV area through the Colorado Coordinated Planning Group (CCPG) Subcommittee. Please make the request to one of the Chairs of the SLV Subcommittee for the Phase I Reliability Study report, if needed.

Re-evaluation of Feasibility Study

For the System Impact Study, PSCo has re-evaluated the Feasibility Study analysis and found the Scenario #3 in the previous report (30 MW sensitivity that Tri-State has requested) no longer needed. Tri-State is no longer pursuing the 30 MW in the San Luis Valley, therefore, has asked PSCo to remove the sensitivity scenario in future generation interconnection studies. As a result, all thermal violations under Scenario #3 were negated, which left the analysis with a single contingency violation. Please refer to Table 1 for detail. PSCo has chosen to not identify any network upgrades for delivery to mitigate the criteria violations and accommodate the new generation interconnection for the time being because there is an ongoing joint transmission study effort between PSCo and Tri-State Generation and Transmission (TSGT) for the SLV area through the Colorado Coordinated Planning Group (CCPG). Everything else remains accurate as previously reported in the Feasibility Study.

Scenario #1) 2016 Heavy Summer with 140 MW total load in the SLV, existing SLV PV generation at 85% of the name plate rating, and the proposed GI-2014-13 plant at 53 MW,

Scenario #2) 2016 Light Spring with 45 MW total load in the SLV, existing SLV PV generation at 85% of the name plate rating, and the proposed GI-2014-13 plant at 53 MW and

Based on the System Impact Study results, it is concluded that the 53 MW rated output of the GI-2014-13 interconnection does not qualify for NRIS; however, some level of ERIS may be injected on a non-firm, as-available basis without requiring any Network Upgrades for Delivery.

Table 1. Scenario #2 Branch Criteria Violation

Scenario No.	Monitored Element	Rating (MVA)	O/L %	Condition
2	Sargent-SLV 115 kV	100	107%	Outage: Poncha – SLV 230 kV

The proposed GI-2014-13 generation addition causes no new voltage violations under the study scenarios studied. However, it should be noted that dynamic reactive power capability is required for the GI-2014-13 generation to meet the +/- 0.95 power factor requirement at the Point Of Interconnection and that the inverters need to be in automatic voltage control mode at all times.

Dynamic Stability Analysis

A dynamic stability analysis was not deemed necessary for this GI based on the “DSGMod” (set to 1) and “QVarMod (set to 1) settings chosen by the Interconnection Customer. There was GI study performed using the SMA KODIAK inverters for the San Luis Valley 230 kV POI (GI-2010-11 report posted in July 2014) with the “DSGMod” set to ‘1’ and “QvarMod” set to ‘1’ showed acceptable dynamic performance. The GI-2014-13 GF is expected to demonstrate acceptable dynamic performance with the “DSGMod” and “QvarMod” set to ‘1’.

The construction for GI-2014-13 interconnection is expected to take 18 months after authorization to proceed is received, so the Interconnection Customer proposed March 1, 2017 commercial operation date may not be feasible.

Short-Circuit Analysis

No circuit breakers are over-duty due to the addition of GI-2014-13. See Table-3 for fault current levels at the POI.

Cost Estimate



The total estimated cost to interconnect the project (in 2016 dollars) is approximately **\$2,760,000** and it does not include the cost for Network Upgrades for Delivery. The cost to interconnect the project includes:

- \$970,000 for PSCo-Owned, Interconnection Customer-Funded interconnection facilities
- \$1,760,000 for PSCo-Owned, PSCo-Funded interconnection facilities
- To be determined - PSCo/TSGT Network Upgrades for Delivery

Please see the cost estimates and schedule for an approximate in-service date in Table 4, Table 5, and Table 6. It is expected that there will be major network upgrades needed to the current transmission system to transfer full power output to PSCo native loads. The cost and the timeframe for completing that work have yet to be determined pending studies performed by the SLV Subcommittee of Colorado Coordinated Planning Group.

Any Interconnection Agreement (IA) requires that certain conditions be met, as follow:

1. The conditions of the Interconnection Guidelines are met.
2. A single point of contact is given to Operations to manage the Transmission System reliably for all projects as found in the Interconnection Guidelines.

The Interconnection Customer must show the ability to operate the solar generation within the required +/- 0.95 power factor range during all operating conditions (0 MW to 53 MW) as measured at the Point of Interconnection (POI). The MVAR output shall be proportional with the output of the plant.

Figure 1. SLV region

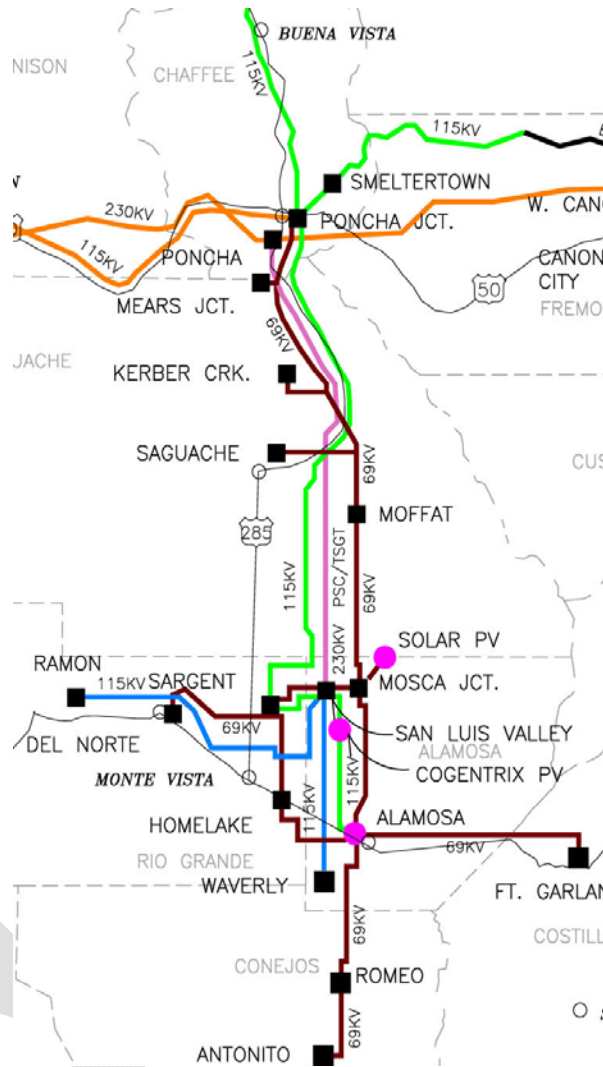
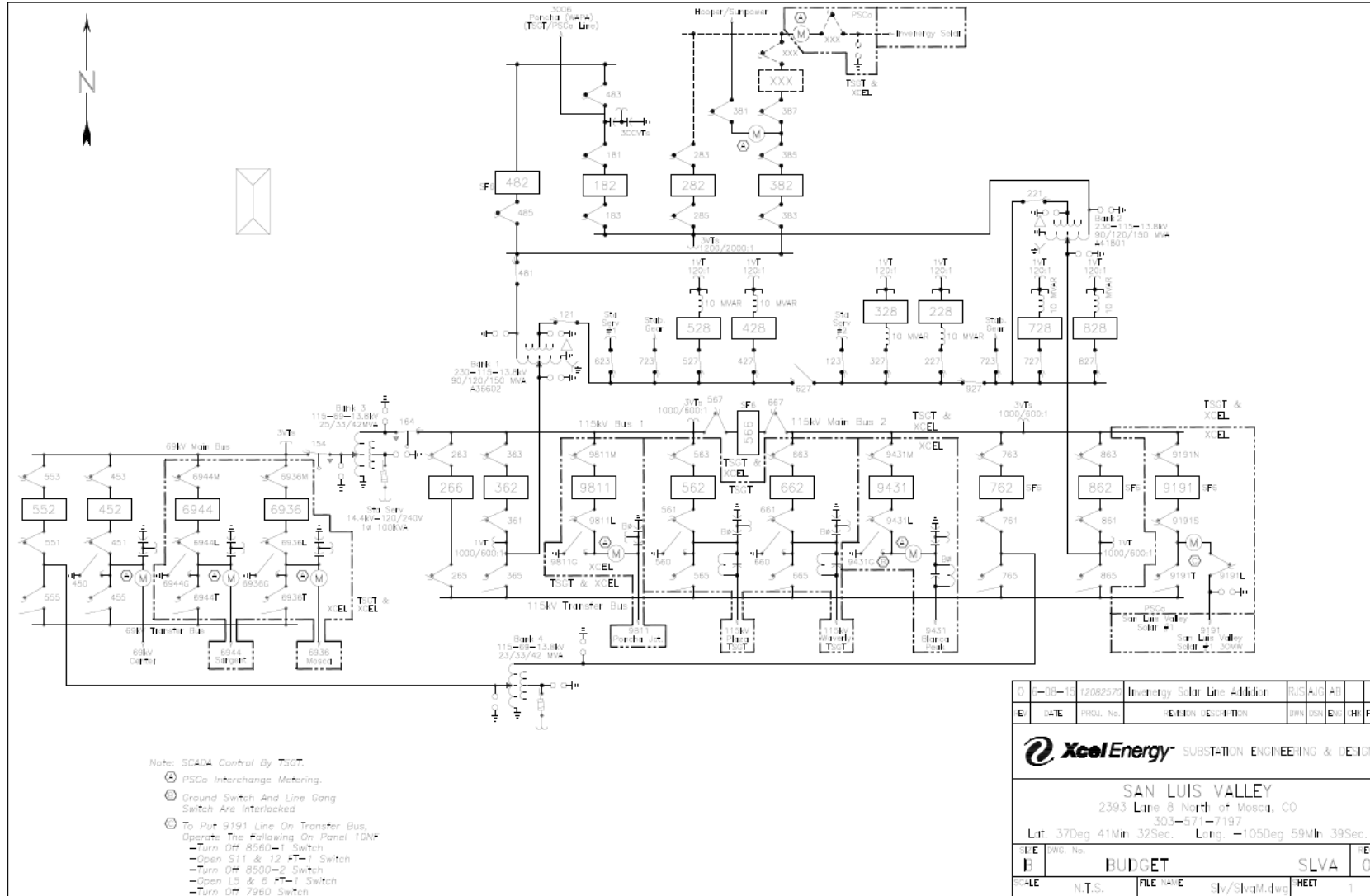

Figure 2. GI-2014-13 Budgeted One-line





Introduction

Public Service Company of Colorado (PSCo) and the Interconnection Customer signed a Generation Interconnection System Impact Study Agreement for 53 MW of solar photovoltaic generation at San Luis Valley (SLV) 230 kV Substation, Colorado. The Interconnection Customer has selected the primary Point of Interconnection (POI) to be at SLV 230 kV bus with no secondary POI. The generating facility (GF) will consist of twenty six (26) 2.2 MVA SMA inverters and will connect to a common 34.5 kV collector bus through two feeder system. Each inverter will have a dedicated 385 V/34.5 kV step-up transformer with an arrangement referred to as a Power Conversion Station (PCS). A single transformer will step the voltage from 34.5 kV to 230 kV for delivery via a 2.9 mile generator tie line.

The proposed COD is March 1, 2017 with an assumed back feed date of six months prior to COD. This COD may not be feasible based on Engineering's requirement of 18 month construction window from the authorization to proceed.

For this interconnection request, the direct affected party is TSGT.

Study Scope and Analysis

The System Impact Study evaluated the transmission impacts associated with the proposed generation increase. It consisted of steady-state power flow and short circuit analyses. The purpose of the steady-state power flow analysis is to identify any branch flow violation or bus voltage limit violations resulting from the generation addition and determine the network upgrades required to mitigate the violations. The short circuit analysis evaluates the impact on the transmission system of the increase in available fault current due to the generation addition (and any network upgrades) and determines the breaker upgrades required to accommodate the increase in available fault current.

This System Impact Study analyzed the impact of this addition, located in southwestern Colorado, in accordance with PSCo's study reliability criteria.

Reliability Criteria

PSCo adheres to NERC Transmission Planning Standards, WECC Reliability Criteria, and PSCo internal company criteria for planning reliability studies.

Power Flow Criteria

Category A – System Normal

“N-0” System Performance under Normal (System Intact) Conditions (Category A)
NERC Standard TPL-001-0

Voltage: 0.95 to 1.05 per unit
Line Loading: 100 percent of continuous rating
Transformer Loading: 100% of highest 65 °C rating

Category B – Loss of generator, line, or transformer (Forced Outage)

“N-1” System Performance Following Loss of a Single Element
(Category B) NERC Standard TPL-002-0

Voltage: 0.90 to 1.10 per unit for 300 kV and below (PSCo)
0.90 to 1.05 per unit for above 300 kV (PSCo)
0.90 to 1.10 per unit for all TSGT busses
Line Loading: 100 percent of continuous rating
Transformer Loading: 100% of highest 65 °C rating

Category C – Loss of Bus or a Breaker Failure (Forced Outage)

“N-2 or More” System Performance Following Loss of Two or More Elements (Category C)
NERC Standard TPL-003-0

Voltage and Branch: Allowable emergency limits will be considered as determined by the affected parties and the available emergency mitigation plan. Curtailment of firm transfers, generation re-dispatch and load shedding will be considered if necessary.

Category D – Extreme Events (Forced Outages)

“N-2 or More” System Performance Following Extreme Events
(Category D) NERC Standard TPL-004-0

Voltage and Branch: Allowable emergency limits as determined by available emergency mitigation plan. Curtailment of firm transfers, generator re-dispatches and load shedding is permissible if necessary.

Category C and Category D disturbances were not conducted for this study.

Interconnection Service Categories

This project was studied as a NRIS and an ERIS. NRIS shall mean an Interconnection Service that allows the Interconnection Customer to integrate its large generating facility with the Transmission Provider's Transmission System in a manner comparable to that in which the Transmission Provider integrates its generating facilities to serve native loads. NRIS in and of itself does not convey transmission service nor can be considered as Designated Network Resource (DNR). ERIS shall mean an Interconnection Service that allows the Interconnection Customer to connect to the Transmission Provider's system and be eligible to deliver the generating facility's output using the existing firm or non-firm capacity of the transmission system on an "as available" basis. ERIS does not in and of itself convey any delivery service.

For this project, TSGT is an "affected party". PSCo will provide TSGT with a copy of this System Impact Study report and will work with TSGT during the Facility Study phase. TSGT may choose to perform the Facility Study or opt to have PSCo do the work under TSGT's collaboration.

WECC Base Case Models

WECC coordinates the preparation of regional power flow base cases for transmission planning purposes. PSCo obtained the WECC 2014HS2 base case (approved in March of 2014) that represents 2014 summer on-peak conditions. From the 2014HS2 case, PSCo developed the study cases that represent the 2016 loading conditions.

Modeling of Request

The new 53 MW photovoltaic solar power plant will transform the collected solar energy to DC currents and voltages and utilize an inverter to convert to AC currents and voltages. The photovoltaic solar power plant will connect to the bulk electric system through a dedicated 34.5-230 kV step-up transformer. For study purposes, the photovoltaic solar power plant was initially rated at 53 MVA with +/- 0.90 power factor. This facility will be interconnected to the PSCo system at the SLV 230 kV bus.



The following is a summary of Project GI-2014-13 parameters as modeled by PSCo in the “2016HS.sav” and “2016LSp.sav” study cases:

Total Plant Capacity	= 53 MW
Reactive Capability	= +/- 0.90 power factor initially modeled,
Generator Step-up Transformer	= 34.5/230 kV step up transformer rated at 56 MVA
Voltage Regulation	= None initially modeled,
Ideal voltage range at SLV 230 kV bus	= 1.02 - 1.03 p.u

Interconnection Requirements

Interconnecting to the PSCo bulk transmission system involves the Interconnection Customer adhering to certain interconnection requirements. These requirements are contained in the document titled “Interconnection Guidelines for Transmission Interconnected Producer-Owned Generation Greater than 20 MW.” In addition, PSCo System Operations conducts commissioning tests prior to the commercial in-service date for the Interconnection Customer’s facilities. Some of the requirements with which the Interconnection Customer must comply include the following:

1. A generating plant shall maintain a power factor within the range of 0.95 leading to 0.95 lagging, measured at the POI, if the Transmission Provider’s System Impact Study shows that such a requirement is necessary to ensure safety or reliability.
2. The results of the System Impact Study does not absolve the Interconnection Customer from its responsibility to demonstrate to the satisfaction of PSCo System Operations prior to the commercial in-service date that it can safely operate within the required power factor and voltage ranges.
3. Reactive Power Control at the POI is the responsibility of the Interconnection Customer. Additional studies should be conducted by the Interconnection Customer to ensure that the facilities can meet the power factor control test and the voltage controller test when the facility is undergoing commissioning testing.

4. PSCo System Operations will require the Interconnection Customer to perform operational tests prior to commercial operation that would verify that the equipment installed by the Interconnection Customer meets operational requirements.
5. It is the responsibility of the Interconnection Customer to determine what type of equipment (Dynamic Volt-Amp Reactive (DVAR), added switched capacitors, Static VAR Compensator (SVC), reactors, etc.), and the locations of those facilities that may be needed for acceptable performance during the commissioning testing.
6. PSCo requires the Interconnection Customer to provide a single point of contact to coordinate compliance with the power factor and voltage regulation at the POI. The reactive flow at the POI, SLV 230 kV bus, will need to be controlled according to the Interconnection Guidelines.

Post GI-2014-13 Study Case Development

Analyses were performed using a 2016 Heavy Summer study case and a 2016 Light Spring study cases were that derived from the WECC approved “2014hs2.sav” base case. The 2016 Heavy Summer study case was developed from the “2014hs2.sav” base case by increasing the demand in SLV (Zone 710) by 2%. . The 2016 Light Spring study case was developed from the “2014hs2.sav” base case by scaling down the total load in the SLV to 45 MW to reflect the historically recorded minimum demand. Based on PSCo Transmission Planning guidelines, all existing photovoltaic generators in the SLV area should be modeled at 85% of name plate rating for all system studies. The two study cases described above were modified to include the proposed GI-2014-13 53 MW generation station. Three additional study cases were created to reflect a Post-GI-2014-13 steady state condition. These are:

- GI-2014-13_post.sav- 2016 Heavy Summer
- GI-2014-13_post.sav- 2016 Light Spring

These cases reflect the addition of the GI-2014-13 generation model with +/- 0.90 power factor range along with dynamic reactive power capability to hold a 1.03 p.u voltage at the SLV 230

kV bus. More detailed modeling information is given in the “Modeling of Request Section” of this report.

Pre GI-2014-13 Model Development

Two additional study cases were developed from the Post GI-2014-13 study cases, described above. They were created by turning off the new generation to create the Pre GI-2014-13 Models. The Cherokee generation was incremented by 53 MW to compensate.

The following Pre-GI-2014-13 steady state models were developed.

- GI-2014-13_pre.sav- 2016 Heavy Summer
- GI-2014-13_pre.sav- 2016 Light Spring

The cases were solved with transformer tap, switched shunt, phase shifter, DC tap adjustment and area interchange adjustment enabled. The following table lists the study cases created.

Table 2. List of Study Cases

Case Name	Originating Case	Changes to Create the Case
2014 Heavy Summer	WECC Base Case	
2016 Heavy Summer	2014 Heavy Summer	Increased SLV (Zone 710) demand 2%
2016 Light Spring	2014 Heavy Summer	Decreased SLV (Zone 710) to 45 MW (minimum SLV historic demand)
GI-2014-13 pre.sav - 2016 Heavy Summer	2016 Heavy Summer	GI-2014-13 generation off-line

GI-2014-13 pre.sav - 2016 Light Spring	2016 Light Spring	GI-2014-13 generation off-line
GI-2014-13 post.sav - 2016 Heavy Summer	2016 Heavy Summer	GI-2014-13 generation at 53 MW
GI-2014-13 post.sav - 2016 Light Spring	2016 Light Spring	GI-2014-13 generation at 53 MW

Power Flow Study Process

Siemens Power Technologies, Inc. (PTI) PSS/E and ACCC computer power flow programs and evaluation software were used to determine system performance. Comparisons were made between the Pre and Post GI-2014-13 results.

The study area was defined as areas 70 (PSCOLORADO) and 73 (WAPA R.M.) in the study cases. All study area elements were monitored. The study considered only the following contingency categories in the study area for the steady state analysis.

- Category A (System Intact).
- Category B (Single Contingencies).

Branch and voltage injection constraints were identified based on the following study criteria:

- The criterion used to flag branch overloads was 100% of the monitored element's continuous rating (Rate A in PSS/E). Branch overloads found on elements outside of Zone 710 (SLV area) that were found as overloads in the Pre GI-2014-13 Analysis were not considered constraints by PSCo.
- The criterion used to flag voltage violations met or exceeded the following criteria.
 - The resultant bus voltage was outside of the acceptable range of 0.95 to 1.05 p.u for system intact conditions or 0.90 p.u. to 1.05 p.u. for single contingencies (both for PSCo and TSGT busses)

- Voltage violations found on elements outside of Zone 710 that were found as voltage violations in the Pre GI-2014-13 Analysis not considered constraints by PSCo.

During the ACCC contingency analysis, models were solved with transformer tap and switched shunt adjustments locked; phase shifter and DC tap adjustments enabled and area interchange adjustment disabled. The analysis results were obtained by comparing results from the Pre GI-2014-13 model to results from the Post GI-2014-13 model to determine the impact of the GI-2014-13 generation on the transmission system.

Steady State Power Flow Analysis

A contingency analysis was performed using study cases, generator models, criteria, and methodology described earlier in this report. The incremental impact of the 53 MW request was evaluated by comparing flows and voltages with and without the new request. This study has identified the system intact (N-0) and single-event contingency (N-1) interconnection constraints. All system intact and single contingency constraints will require mitigation prior to granting the subject request.

Scenario #1 - 2016 Heavy Summer Analysis Results (140 MW of Load in SLV)

branch

No new 2016 Heavy Summer system intact or single contingency branch constraints due to the subject request were found.

voltage

No new 2016 Heavy Summer system intact or single contingency voltage constraints due to the subject request were found; however, with heavy loading conditions, existing low voltages were observed in the local 115 kV and 69 kV systems for both the pre and post project system conditions for the simulated contingencies. To mitigate the low voltages, a load shedding scheme is currently in place to trip load and existing local generation can be turned on to provide additional reactive support. For the purpose of this study, the required load shedding scheme was not evaluated.

Scenario #2 - 2016 Light Spring Analysis Results (45 MW of Load in SLV)

branch

One N-1 branch constraint due to the subject request was found.

- 1) Sargent – SLV 115 kV (rated 100 MVA)

voltage

No new 2016 Light Summer system intact or single contingency voltage constraints due to the subject request were found.

Study Results Conclusion

The System Impact Study results demonstrate that the 53 MW rated output of the GI-2014-13 interconnection does not qualify for NRIS. Some level of ERIS may be injected on a non-firm, as-available basis without requiring any Network Upgrades for Delivery. The addition of the proposed GI-2014-13 generation facility will cause the Sargent–SLV 115 kV (rated 100 MVA) to overload for Scenario #2 under a contingency condition (an outage of the Poncha-SLV 230 kV line).

The proposed generation caused no new voltage violations. However it should be noted that dynamic reactive power capability is required of the GI-2014-13 generation to meet the +/- 0.95 power factor requirement at the point of interconnection and the inverters need to be in automatic voltage control mode at all times.

No new 2016 Heavy Summer system intact or single contingency voltage constraints due to the subject request were found; however, with heavy loading conditions, existing low voltages were observed in the local 115 kV and 69 kV systems for both the pre and post project system conditions for the simulated contingencies. To mitigate the low voltages, a load shedding scheme is currently in place to trip load and existing local generation can be turned on to provide additional reactive support for the loss of Poncha – San Luis Valley 230 kV line. For the purpose of this study, the required load shedding scheme was not evaluated.

Voltage Regulation and Reactive Power Capability

Interconnection Customers are required to interconnect their Large Generating Facilities with Public Service Company of Colorado's (PSCo) Transmission System in conformance to the Xcel

Energy's "Interconnection Guidelines for Transmission Interconnected Producer-Owned Generation Greater Than 20 MW" (available on Xcel Energy's website). Wind and Solar generating plant interconnections (Variable Energy Resources) must also conform to the performance requirements in FERC Order 661-A. Accordingly, the following voltage regulation and reactive power capability requirements (at the POI) are applicable to this interconnection request.

- To ensure reliable operation, Generating Facilities interconnected to the PSCo transmission system are encouraged to adhere to the Rocky Mountain Area Voltage Coordination Guidelines. Accordingly, since the POI for this request is located within Southeast Colorado Region 4, the applicable ideal transmission system voltage profile range is 1.02 – 1.03 per unit at regulated buses and 1.0 – 1.03 per unit at non-regulated buses.
- Xcel Energy's OATT requires all Interconnection Customers to have the reactive capability to achieve ± 0.95 power factor at the POI, with the maximum "full output" reactive capability available at all output levels. Furthermore, Xcel Energy requires all Interconnection Customers to have dynamic voltage control and maintain the voltage specified by the Transmission Operator within the limitation of ± 0.95 power factor at the POI, as long as the generating plant is on-line and producing power.
- It is the responsibility of the Interconnection Customer to determine the type (switched shunt capacitors and/or switched shunt reactors, etc.), the size (MVAR), and the locations (690 volts, 34.5 kV or 230 kV bus) of any additional static reactive power equipment needed within the generating plant in order to have the reactive capability to meet the ± 0.95 power factor and the 1.02 – 1.03 per unit voltage range standards at the POI. The Interconnection Customer may need to perform additional studies for this purpose.

Short Circuit

A short circuit analysis was performed. The short circuit case reflects the three phase and single-line-to-ground fault currents at the SLV 230 kV bus with and without the GI-2014-13 53 MW SLV generation station.

Table 3 – Short-circuit study results at SLV 230 kV bus.

System Condition	3 Φ (A)	S-L-G (A)
Pre-Project	2825	3436
Post-Project	3048	3765

Cost Estimate

Scoping level cost estimates for Interconnection Facilities and Network/Infrastructure Upgrades for Delivery (+/- 30% accuracy) were developed by Public Service Company of Colorado (PSCO) / Xcel Energy (Xcel) Engineering. The cost estimates are in 2016 dollars with escalation and contingency factors included. AFUDC is not included. Estimates are developed assuming typical construction costs for previous completed projects. These estimates include all applicable labor and overheads associated with the siting support, engineering, design, material/equipment procurement, construction, testing and commissioning of these new substation and transmission line facilities.

The estimated total cost for the required upgrades is **\$2,760,000**. These estimates do not include costs for any other Interconnection Customer owned equipment and associated design and engineering. The following tables list the improvements required to accommodate the interconnection and the delivery of the Project generation output. The cost responsibilities associated with these facilities shall be handled as per current FERC guidelines. System improvements are subject to change upon a more detailed and refined design.

Table 4 – PSCo Owned; Interconnection Customer Funded Transmission Provider Interconnection Facilities

Element	Description	Cost Est. (Millions)
San Luis Valley 230 kV Transmission Substation	Interconnect Customer to tap at the SLV 230 kV Transmission Substation (into the 230 kV bus). The new equipment includes: <ul style="list-style-type: none"> • One 230 kV gang switch • Three 230 kV arresters • One set 230 kV CT/PT metering units • Station controls • Instrument transformers • Associated bus, wiring and equipment • Associated site development, grounding, foundations and structures • Associated transmission line communications, relaying and testing 	\$0.790
	Transmission line relocation and tap into substation. Structures, conductor, insulators, hardware and labor.	\$0.160
	Siting and Land Rights support for siting studies, land and ROW acquisition and construction.	\$0.020
	Total Cost Estimate for PSCo-Owned, Interconnection Customer-Funded Interconnection Facilities	\$0.970
Time Frame	Site, design, procure and construct	18 Months

Table 5 – PSCo Owned; PSCo Funded Interconnection Network Facilities

Element	Description	Cost Estimate (Millions)
San Luis Valley 230 kV Transmission Substation	Interconnection Customer to tap at SLV 230 kV Transmission Substation (into the 230 kV bus). The new equipment includes: <ul style="list-style-type: none"> • One 230 kV circuit breaker • One 230 kV gang switch • Three 230 kV arresters • Control Building (Electric Equipment Enclosure) • Station battery system upgrades • Station controls • Associated communications, supervisory and SCADA equipment • Associated line relaying and testing • Associated bus, miscellaneous electrical equipment, cabling and wiring • Associated foundations and structures • Associated road and site development, fencing and grounding 	\$1.770
	Siting and Land Rights support for substation land acquisition and construction.	\$0.020
	Total Cost Estimate for PSCo-Owned, PSCo-Funded Interconnection Facilities	\$1.790
Time Frame	Site, design, procure and construct	18 Months

Table 6 – PSCo/TSGT Network Upgrades for Delivery (To be determined)

Element	Description	Cost Est. (Millions)
San Luis Valley 230 kV Transmission Substation	None	TBD
	Total Cost Estimate for PSCo/TSGT Network Upgrades for Delivery Facilities	TBD
Time Frame	Site, design, procure and construct	

Cost Estimate Assumptions

- Scoping level project cost estimates for Interconnection Facilities and Network/Infrastructure Upgrades for Delivery (+/- 30% accuracy) were developed by PSCo Engineering.

- Estimates are based on 2016 dollars (appropriate contingency and escalation included).
- AFUDC has been excluded.
- Labor is estimated for straight time only – no overtime included.
- Lead times for materials were considered for the schedule.
- The Solar Generation Facility is not in PSCo’s retail service territory. Therefore, no costs for retail load (distribution) facilities and metering required for station service are included in these estimates.
- PSCo and/or TSGT (or the Contractor) crews will perform all construction, wiring, testing and commissioning for PSCo owned and maintained facilities.
- The estimated time to site, design, procure and construct the interconnection and network delivery facilities is approximately 18 months after authorization to proceed has been obtained.
- A CPCN will not be required for the interconnection and network delivery facilities construction.
- The Interconnection Customer will be required to design, procure, install, own, operate and maintain a Load Frequency/Automated Generation Control (LF/AGC) RTU at the Interconnection Customer’s substation. PSCo / Xcel will need indications, readings and data from the LFAGC RTU.
- Interconnection Customer will string OPGW fiber into substation as part of the transmission line construction scope.
- No new substation land will need to be acquired.
- Breaker duty study determined that no breaker replacements are needed in neighboring substations.

GI-2014-13

Appendix A - Detailed Steady State Analysis Results

No 2016 Heavy Summer branch or voltage constraints were found. However, one 2016 Light Spring branch constraints were identified.

Table 7 – Branch Impacts of Interest

Limiting Element	Rating N/E	16HS Pre GI-2014-13		16HS Post GI-2014-13		16LSp Pre GI-2014-13		16LSp Post GI-2014-13		Contingency
		MVA	%	MVA	%	MVA	%	MVA	%	
PONCHA-SARGENT 115 kV	120	33	28	24	20	65	54	115	97	PONCHA – SLV 230 kV
SARGENT-SLV 115 kV	100*	12	12	46	46	62	62	107	107	PONCHA – SLV 230 kV

*Breaker CT's at SLV Substation is limiting element. This limiting element will be replaced as a normal course of business under FAC-8 capital budget blanket.

GI-2014-13

Appendix B - Generation Dispatch

Table 8. Dispatch of All Generating Units in the Immediate Vicinity of GI-2014-13 (Zone 710)

Bus	LF Id	Maximum Generation MW	2016 Heavy Summer MW	2016 Light Spring MW
G-SANDHIL_PV	S1	16	13.6	13.6
IBERDROLA_PV	S2	30	25.5	25.5
COGENTRIX_PV	S1	30	25.5	25.5
SUNPOWER	S1	52	44.2	44.2
ALMSACT1	G1	17	Off-line	Off-line
ALMSACT2	G2	19	Off-line	Off-line
GI-2014-13	S1	53	53	53
MOSCA	NT	8	6.8	6.8
TSGT'S QUEUE	S1	0	0	0

*Note – On average, all photovoltaic generation in the SLV are at 85% of name plate for all generation interconnection studies per PSCo Planning interconnection guidelines, effective March, 2015.