



Interconnection Feasibility/System Impact Study Report Request # GI-2014-8

60 MW Photovoltaic Solar Generator
Boone 230 kV Substation, Colorado

Public Service Company of Colorado
Transmission Planning
April 3, 2015

Executive Summary

This study report includes the Feasibility and System Impact studies for interconnecting a 60MW solar photovoltaic generator, GI-2014-8 at the Boone 230 kV Substation. The interconnection request for GI-2014-8 was received on August 4, 2014 and study agreement was executed on October 29, 2014. The original request was for a Feasibility study only, but the Customer had changed it to a combined Feasibility and System Impact study in the email received on August 19, 2014. The proposed GI-2014-8 will consist of Eaton Power Xpert Solar 1500 inverters and will be located approximately 0.25 miles North West of the Boone Substation. The Customer requested the primary Point of Interconnection (POI) on the Boone 230 kV bus; a secondary POI has not been selected. GI-2014-8 will be connected to the Boone 230 kV Substation using a customer owned 230 kV tie line. The proposed solar generating facility is planned to be in-service in December 2016 with a back feed date of June 2016. The study request is for both Energy Resource and Network Resource service.

The affected parties for this study are Colorado Springs Utilities (CSU), Black Hills Colorado Electric (BHCE) and Tri-State Generation & Transmission Inc (TSGT).

This request was studied as a stand-alone project only, with no evaluations made of other potential new generation requests that may exist in the Generator Interconnection Request queue, other than the resource acquisitions approved in PSCo's 2013 Energy Resource Plan (ERP) for which Power Purchase Agreements have been signed. The system impact study consisted of steady state power flow contingency analysis and short circuit analysis. These analyses did not identify any thermal or voltage violations, or any over-dutied circuit breakers, that may be attributed to the GI-2014-8 interconnection. However, the power flow analysis did identify several pre-existing thermal overloads that must be mitigated - PSCo Transmission Planning is currently pursuing a project to install a Series reactor at the Palmer Lake Substation which would mitigate these pre-existing thermal overloads. This planned system upgrade will allow generation of 60 MW at GI-2014-8 as both Energy Resource and Network Resource.



No stability analysis was performed since the dynamic performance of the solar generation facility for normally cleared faults was expected to be satisfactory based on the proprietary information on Voltage Ride Through (VRT) capability of the Eaton Power Xpert Solar 1500 inverters provided by the Interconnection Customer. Furthermore, it is the responsibility of the Interconnection Customer to ensure that its generating facility is capable of meeting the voltage ride-through and frequency ride-through (VRT and FRT) performance specified in the NERC Reliability Standard PRC-024-1.

The study was performed to simulate heavy south – north flows in the study area and Lamar DC tie was modeled importing at 101MW. Based on the system impact study, it is concluded that the full 60 MW rated output of the GI-2014-8 interconnection qualifies for Network Resource Interconnection Service (NRIS) without requiring any Network Upgrades for Delivery attributed to GI-2014-8. However, until the transmission reinforcement needed to mitigate the three 115 kV transmission facilities with thermal overloads (see Table 5 in Appendix) is placed in-service, the GI-2010-19 output would be deliverable as Energy Resource Interconnection Service (ERIS) using the existing firm/non-firm transmission capacity on an as available basis.

Short Circuit

The short circuit study results showed no new circuit breakers overdutied due to the proposed solar generation facility. See Table 1 for short circuit data.

Cost Estimates

The cost for the transmission interconnection (in 2015 dollars):

Transmission Proposal

The total estimated cost of the recommended system improvements to interconnect the project is approximately **\$2.627 Million** and includes:

- \$ 1.498 million for PSCo-Owned, Customer-Funded Interconnection Facilities
- \$ 1.129 million for PSCo-Owned, PSCo-Funded Network Upgrades for Interconnection
- \$ 0 million for PSCo Network Upgrades for Delivery to PSCo Loads

This work can be completed in 18 months following receipt of authorization to proceed.

The Interconnection Agreement (IA) requires that certain conditions be met, as follows:

- 1 The conditions of the Large Generator Interconnection Guidelines (LGIG) are met.

- 2 PSCO will require testing of the full range of 0 MW to 60 MW operational capability of the facility to verify that the facility can safely and reliably operate within required power factor and voltage ranges.
- 3 A single point of contact needs to be provided to PSCo Operations to facilitate reliable management of the transmission system.

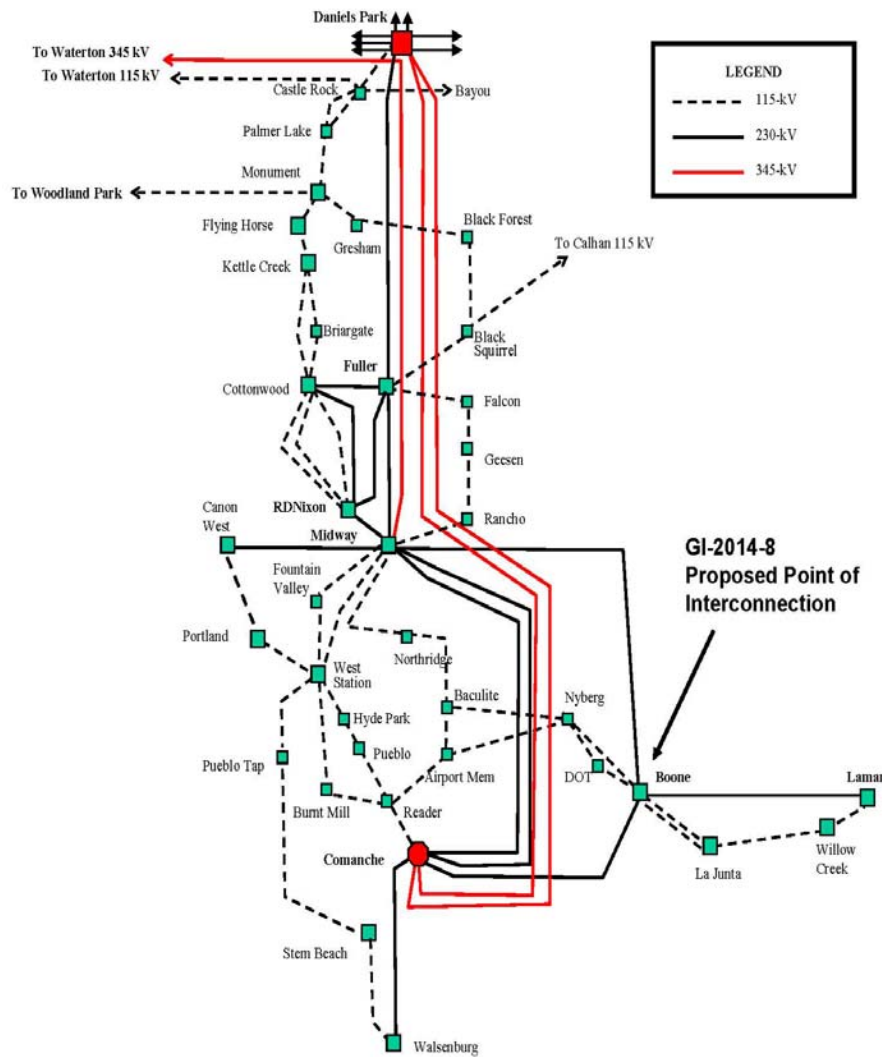

Figure 1 Boone Substation and Surrounding Transmission System

Introduction

Public Service Company of Colorado (PSCo) received an interconnection request (GI-2014-8) for a 60 MW Solar Photovoltaic generation facility near the Boone 230 kV Substation in Pueblo County, Colorado. The interconnection request for GI-2014-8 was received on August 4, 2014 and study agreement was executed on October 29, 2014. The Customer had originally requested Feasibility study only, but changed the request to a combined Feasibility and System Impact study in an email received on August 19, 2014. The proposed GI-2014-8 will consist of Eaton Power Xpert Solar 1500 inverters and will be located approximately 0.25 miles North West of the Boone Substation. The Customer requested the primary Point of Interconnection (POI) on the Boone 230 kV bus; a secondary POI had not been selected. GI-2014-8 will be connected to the Boone 230 kV Substation using a customer owned 230 kV tie line.

The proposed POI of GI-2014-8 is shown in Figure 1 above. The proposed facility has a planned in-service date of December 2016 with an estimated back feed date of June 2016.

The combined Feasibility and System Impact Study consists of steady-state power flow analyses to evaluate the thermal and voltage impacts of the proposed generating plant on the transmission system, as well as determine the adequacy of the generating plant's power factor range (reactive power capability) at the POI. Based on the inverter technical specifications provided by the Interconnection Customer, it is expected that the inverters will have 0.90 lead – 0.90 lag adjustable power factor capability such that the PV solar generating plant's automatic voltage regulator will be capable of being operated in either voltage control or power factor control modes..

Recognizing the 0.90 lead – 0.90 lag adjustable power factor capability of the inverters, along with the proprietary information on Voltage Ride Through (VRT) capability of the inverters provided by the Interconnection Customer, a transient stability study to assess and/or verify the interconnecting generating facility's voltage ride-through for normally cleared faults was not deemed necessary. Further, since the inverters constitute an asynchronous interface of the PV solar generating plant to the transmission system, this interconnection does not contribute any electromechanical oscillations that may adversely impact the rotor-angle stability of existing synchronous generators.

The customer is required to provide the Voltage Ride Through and Frequency Ride Through curves for the GI before energizing

Study Scope and Analysis

The combined Feasibility and System Impact Study evaluated the potential impacts on the PSCo transmission infrastructure as well as that of neighboring utilities when an additional 60 MW of generation is injected into the Boone 230 kV bus, and delivering this generation to native PSCo loads. The combined Feasibility and System Impact

study consisted of power flow and short circuit analyses. The power flow analysis identified any thermal or voltage limit violations resulting from the installation of the proposed generation. Several single and double contingencies were studied. The short circuit analysis identified any new circuit breakers overdutied due to the proposed generation and the short circuit current levels at the POI.

PSCo adheres to NERC & WECC Reliability Criteria, as well as internal Company criteria for planning studies. During system intact conditions, criteria are to maintain transmission system bus voltages between 0.95 and 1.05 per unit of nominal and steady-state power flows below the thermal ratings of all facilities. Operationally, PSCo tries to maintain a transmission system voltage of 1.02 per unit or higher at regulating (generator) buses and 1.0 per unit or higher per unit at transmission load buses in the study area. Following a single or double contingency, transmission system steady state bus voltages must remain within 0.90 - 1.05 per unit, and power flows must remain within 100% of the facility's continuous thermal ratings. Also, voltage deviations should not exceed 5%.

The proposed facility was requested to be studied as both Energy Resource and Network Resource interconnection.

Energy Resource Interconnection Service shall mean an Interconnection Service that allows the Interconnection Customer to connect its Generating Facility to the Transmission Provider's Transmission System to be eligible to deliver the Generating Facility's electric output using the existing firm or non-firm capacity of the Transmission Provider's Transmission System on an as available basis. Energy Resource Interconnection Service in and of itself does not convey transmission service.

Network Resource Interconnection Service shall mean an Interconnection Service that allows the Interconnecting Customer to integrate its Large Generating Facility with the Transmission Provider's Transmission System (1) in a manner comparable to that in which the Transmission Provider integrates its generating facilities to serve native load customers; or (2) in an RTO or ISO with market based congestion management, in the same manner as all other Network Resources. Network Resource Interconnection Service in and of itself does not convey transmission service.

The affected parties for this study are CSU, TSGT and BHCE.

Power Flow Study Models

The study was based on the WECC 2015HS base case released on December 5, 2014 and was update to reflect 2016 heavy summer modeling. The updates included topology, generation, load and rating updates to the PSCo, TSGT, BHCE, IREA and CSU systems.

BHCE updates included modeling of a fifth 90MW Baculite Mesa Generator connecting to BHCE's Baculite substation.

To assess the impact of the proposed generation on the interconnected transmission system, the generation dispatch in the reference case was adjusted to create a south to north power flow stress on the Comanche – Midway - Jackson Fuller – Daniels Park transmission path. This was accomplished by adopting the generation dispatch described in Table - 8 below. PSCo generation in the study area (zones 700, 704, 710, 712, 752, 757, 790 and 791) is dispatched such that wind generation is at 85% name plate capacity, solar generation is at 80% name plate capacity and conventional non-coal generation is at 90% name plate capacity, coal generation is dispatched at 100% name plate capacity. The study did not include any generation in the Generation Interconnection queue but all resource acquisitions approved in PSCo's 2013 Energy Resource Plan (ERP) for which Power Purchase Agreements (PPA's) have been signed are included. The Lamar dc tie is dispatched at 101 MW import into PSCo and the Colorado Green / Twin Buttes wind generation (interconnected at Lamar) is dispatched to 197.3 MW such that flow on the Boone - Lamar 230 kV line is limited to 196MW which is PSCo's ownership capacity. The resulting PSCo (Area 70) generation dispatch can be found in Appendix B.

Two power flow cases were created for evaluating the system impact of the proposed generator – the reference case and the study case. The study case includes the 120 MW generation dispatch at Comanche 230 kV bus due to the proposed generator interconnection. Generation increase due to the proposed GI addition was sunk at RMEC # 3.

Power Flow Study Process

Contingency power flow studies were completed on the reference power flow case and the study case (power flow case with GI 2014-8) using PTI's PSSE Ver. 33.4.0 program. Results from each of the two cases were compared and, the monitoring criteria is to list any new thermal and voltage violations. The PSSE Ver. 33.4.0 ACCC contingency analysis activity was used to perform the load flow contingency analysis. The PSCo Category C analysis was performed using contingency definitions that reflect breaker to breaker outages, Category B analysis was performed using bus-bus switching and where violations are seen, the correct breaker – breaker contingency is identified and run. Category B outages were run in entire areas 70 and 73 where Category C outages were modeled for 700, 704, 705, 709, 712, 752, 757, 790, and 791. The facilities in Zones 700, 704, 710, 712, 752, 757, 790 and 791 were monitored for overloads and voltage problems.

Power Flow Results

Network Resource Interconnection Service

The results of the Network Resource contingency analysis are summarized in the tables in the Appendix. The results of the Category B contingency analysis (see Table 5)

show three 115 kV transmission facilities which are wholly-owned by CSU. Since both the CSU 115 kV transmission facilities are overloaded prior to the GI-2014-8 interconnection, none of these three thermal overloads can be attributed to the proposed 60 MW injection at Boone 230 kV by GI-2014-8. The study results showed no new voltage violations.

However PSCo's planned Monument – Palmer Series reactor project will mitigate these pre-existing overloads on the three CSU 115 kV transmission lines, as seen in Table 6.

Energy Resource Interconnection Service

As defined in above, Energy Resource Interconnection Service allows the Customer to deliver a Generating Facility's electric output using the existing firm or non-firm capacity of the Transmission Provider's Transmission System on an as available basis.

Therefore, until the transmission reinforcement needed to mitigate the thermal overloads on the three 115 kV CSU transmission facilities is in place, the GI-2010-19 output would be deliverable as Energy Resource Interconnection Service (ERIS) using the existing firm/non-firm transmission capacity on an as available basis. ER capacity is dependent on system condition and can be between 0 to 60 MW on as available basis, including BHCE's Bush Ranch wind generation. The case was studied with BHCE's Bushranch Wind generation at 12% capacity factor.

Voltage Regulation and Reactive Power Capability

Interconnection Customers are required to interconnect their Large Generating Facilities with Public Service of Colorado's (PSCo) Transmission System in conformance to the *Xcel Energy Interconnection Guidelines for Transmission Interconnected Producer-Owned Generation Greater Than 20 MW* (available at <http://www.xcelenergy.com/staticfiles/xcel/Regulatory/Transmission-Interconnection-Guidelines-Great-20MW.pdf>). Wind and Solar generating plant interconnections (Variable Energy Resources) must also conform to the performance requirements in FERC Order 661-A. Accordingly, the following voltage regulation and reactive power capability requirements (at the POI) are applicable to this interconnection request:

- To ensure reliable operation, all Generating Facilities interconnected to the PSCo transmission system should adhere to the Rocky Mountain Area Voltage Coordination Guidelines. Accordingly, since the POI for this interconnection request is located within Southeast Colorado Region 4; the applicable ideal transmission system voltage profile range is 1.02 – 1.03 per unit at regulated buses and 1.0 – 1.03 per unit at non-regulated buses.
- Xcel Energy's OATT requires all Interconnection Customers to have the reactive capability to achieve +/- 0.95 power factor at the POI, with the maximum "full output" reactive capability available at all output levels. Furthermore, Xcel Energy requires all Interconnection Customers to have dynamic voltage control and maintain the voltage specified by the Transmission Operator within the limitation

of +/- 0.95 power factor at the POI, as long as the generating plant is on-line and producing power.

- It is the responsibility of the Interconnection Customer to determine the type (switched shunt capacitors and/or switched shunt reactors, etc.), the size (MVAR), and the locations (690 V, 34.5 kV or 230 kV bus) of any additional static reactive power equipment needed within the generating plant in order to have the reactive capability to meet the +/- 0.95 power factor and the 1.02 – 1.03 per unit voltage range standards at the POI. The Interconnection Customer may need to perform additional studies for this purpose.
- It is the responsibility of the Interconnection Customer to ensure that its generating facility is capable of meeting the voltage ride-through and frequency ride-through (VRT and FRT) performance specified in NERC Reliability Standard PRC-024-1.
- The Interconnection Customer is required to demonstrate to the satisfaction of PSCo Transmission Operations prior to the commercial in-service date of the generating plant that it can safely and reliably operate within the required power factor and voltage ranges noted above.

Dynamic Stability Analysis – Results

Recognizing the 0.90 lead – 0.90 lag adjustable power factor capability of the inverters, along with the proprietary information on Voltage Ride Through (VRT) capability of the inverters provided by the Interconnection Customer, a transient stability study to assess and/or verify the interconnecting generating facility’s voltage ride-through for normally cleared faults was not deemed necessary. Furthermore, it is the responsibility of the Interconnection Customer to ensure that its generating facility is capable of meeting the voltage ride-through and frequency ride-through (VRT and FRT) performance specified in the NERC Reliability Standard PRC-024-1. It is also recognized that since the inverters constitute an asynchronous interface of the PV solar generating plant to the transmission system, this interconnection does not contribute any electromechanical oscillations that may adversely impact the rotor-angle stability of existing synchronous generators.

Short Circuit

The calculated short circuit levels and Thevenin system equivalent impedances for the POI at the Comanche 230kV bus are tabulated below. No PSCo breakers were found to be overdutied due to the proposed interconnection. The inverters of GI-2014-8 are not expected to contribute any significant fault currents.

Table 1 – Short Circuit Parameters at the Boone 230 kV POI

System Condition	Three-Phase Fault Level (Amps)	Single-Line-to-Ground Fault Level (Amps)	SLG X/R	3 Phase X/R
------------------	--------------------------------	--	---------	-------------



System Intact	9505.7	8629.8	13.871	10.089
---------------	--------	--------	--------	--------

Costs Estimates and Assumptions

Scoping level cost estimates for Interconnection Facilities and Network/Infrastructure Upgrades for Delivery (+/- 30% accuracy) were developed by Public Service Company of Colorado (PSCo) / Xcel Energy (Xcel) Engineering. The cost estimates are in 2015 dollars with escalation and contingency included. AFUDC is not included. Estimates are developed assuming typical construction costs for previous completed projects. These estimates include all applicable labor and overheads associated with the siting support, engineering, design, material/equipment procurement, construction, testing and commissioning of these new substation and transmission line facilities. This estimate does not include the cost for any other Customer owned equipment and associated design and engineering.

The estimated total cost for the required upgrades is **\$2.627 Million**. Figure 2 below represents a conceptual one-line of the proposed interconnection into the 230kV bus at the Boone Transmission Substation. These estimates do not include costs for any other Customer owned equipment and associated design and engineering. The following tables list the improvements required to accommodate the interconnection and the delivery of the Project generation output. The cost responsibilities associated with these facilities shall be handled as per current FERC guidelines. System improvements are subject to change upon a more detailed and refined design.

Table 2 – PSCo Owned; Customer Funded Transmission Provider Interconnection Facilities

Element	Description	Cost Est. (Millions)
Boone 230kV Transmission Substation	Interconnect Customer to tap at the Boone 230kV Transmission Substation (into the 230kV bus). The new equipment includes: <ul style="list-style-type: none"> • One 230kV gang switch • Three 230kV arresters • One set 230kV CT/PT metering units • AR15 communications equipment • Associated bus, wiring and equipment • Associated site development, grounding, foundations and structures • Associated transmission line communications, station controls, line relaying and testing 	\$1.224
Customer's 230kV Substation	Load Frequency/Automated Generation Control (LF/AGC) RTU and associated equipment.	\$0.274
	Total Cost Estimate for PSCo-Owned, Customer-Funded Interconnection Facilities	\$1.498

Time Frame	Site, design, procure and construct	18 Months
-------------------	--	------------------

Table 3: PSCo Owned; PSCo Funded Interconnection Network Facilities

Element	Description	Cost Estimate (Millions)
Boone 230kV Transmission Substation	Interconnect Customer to tap at Boone 230kV Transmission Substation (into the 230kV bus). The new equipment includes: <ul style="list-style-type: none"> • One 230kV circuit breaker • One 230kV gang switches • Associated communications, supervisory and SCADA equipment • Associated breaker failure relaying, station controls and testing • Associated bus, miscellaneous electrical equipment, cabling and wiring • Associated foundations and structures • Associated road and site development, fencing and grounding • Associated station battery upgrades 	\$1.129
	Total Cost Estimate for PSCo-Owned, PSCo-Funded Interconnection Facilities	\$1.129
Time Frame	Site, design, procure and construct	18 Months

Table 4 – PSCo Network Upgrades for Delivery

Element	Description	Cost Est. (Millions)
	N/A	

Cost Estimate Assumptions

- Scoping level project cost estimates for Interconnection Facilities and Network/Infrastructure Upgrades for Delivery (+/- 30% accuracy) were developed by PSCo / Xcel Engineering.
- Estimates are based on 2015 dollars (appropriate contingency and escalation included).
- AFUDC has been excluded.
- Labor is estimated for straight time only – no overtime included.
- Lead times for materials were considered for the schedule.
- The Solar Generation Facility is not in PSCo’s retail service territory. Therefore, no costs for retail load (distribution) facilities and metering required for station service are included in these estimates. The

Customer has to secure Station Service from the local utility which serves that area

- PSCo / Xcel (or our Contractor) crews will perform all construction, wiring, testing and commissioning for PSCo owned and maintained facilities.
- The estimated time to site, design, procure and construct the interconnection and network delivery facilities is approximately 18 months after authorization to proceed has been obtained.
- A CPCN will not be required for the interconnection and network delivery facilities construction.
- The Customer will be required to design, procure and install a Load Frequency/Automated Generation Control (LF/AGC) RTU at their Customer Substation.
- Customer will string OPGW fiber into substation as part of the transmission line construction scope.
- No new substation land will need to be acquired.



A. One-Line of Proposed GI-2014-8 Interconnection at Boone 230kV Station

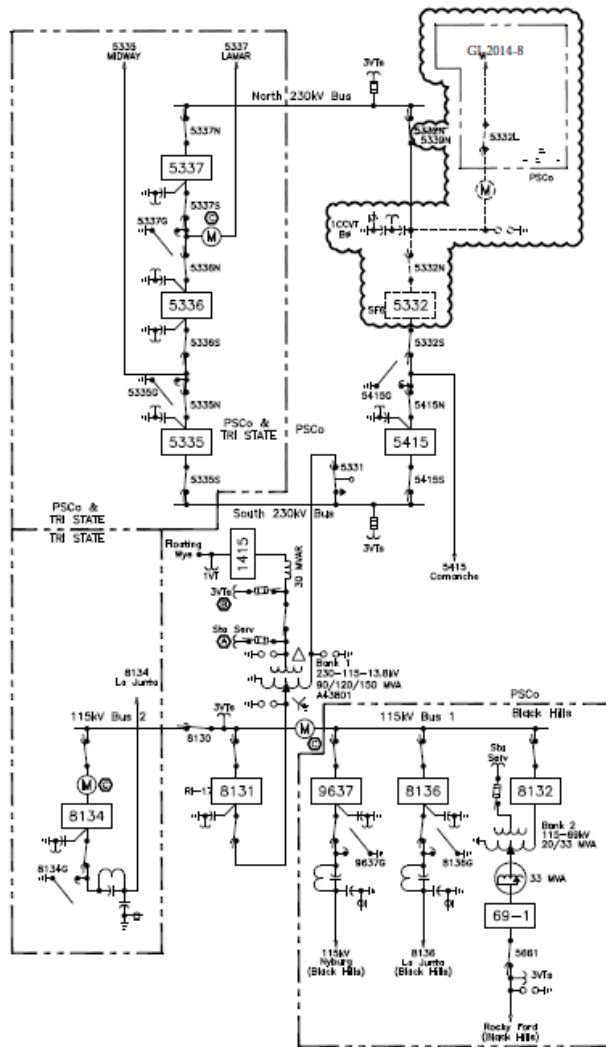
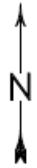

- RI - Relay Instruction
- ⓐ AC Supply For Telemetry. Notify Before Opening.
- ⓑ Reactor Protection.
- Ⓒ Interchange Metering.

REV	DATE	PROJ. No.	REVISION DESCRIPTION	DRN	DSN	ENG	CHK	PLM
B	01-12-15		Added Ownership Line, BKR #	DM		TS		
A	12-03-14		New Line to RES America	KIK		TLS		

SUBSTATION ENGINEERING & DESIGN

BOONE

2mi. NE of Boone on Boone rd. (approx. 20mi. East of Pueblo on Hwy 96) 719-947-3336
 Lat. 38Deg 15Min 21Sec Long. -104Deg 13Min 27Sec

SIZE	DWG. No.	REV
B	BUDGET BOON	B
SCALE	N.T.S.	FILE NAME South/BoonBL.dwg SHEET 1

GI-2014-8



B. Load Flow Thermal Results

Table 5 – Summary Listing of Differentially Overloaded Facilities Without Palmer Lake Series Reactor in-service
% Change calculated based on Normal Ratings.

				Branch Contingency Loading Without GI-2014-8		Branch Contingency Loading With GI-2014-8			
Monitored Facility (Line or Transformer)	Type	Owner	Branch Rating MVA (Norm/Emer)	N-1 Flow MVA	N-1 Flow % of Rating	N-1 Flow MVA	N-1 Flow % of Rating	% Change	NERC Cat B Contingency
Brairgate S – CottonWood S 115 kV	Line	CSU	150/192	163.5	109%/85.1%	166.4	111%/86.7%	2%	Cottonwood N – KettleCreek S 115 kV
Cottonwood N - Kettle Creek S 115 kV	Line	CSU	162/180	175.7	108.5%/97.6%	179.1	110.6%/99.5%	2.1%	Brairgate S-CottonWood S 115 kV
Monument – Fly horse N 115 kV	Line	CSU	120/120	122	101.7%/101.7%	126.3	105.2%/105.2%	3.5%	BLk SQMV- Jackson Fuller 115 kV Line



Table 6 – Summary Listing of Differentially Overloaded Facilities with Palmer Lake Series Reactor in-service % Change calculated based on Normal Ratings.

Monitored Facility (Line or Transformer)	Type	Owner	Branch Rating MVA (Norm/Emer)	Branch Contingency Loading Without GI-2014-8		Branch Contingency Loading With GI-2014-8		% Change	N-1 Contingency Outage
				N-1 Flow MVA	N-1 Flow % of Rating	N-1 Flow MVA	N-1 Flow % of Rating		
Brairgate S - CottonWood S 115 kV	Line	CSU	150/192	147.1	98%/76.6%	149	99.4%/77.6%	1.4%	Cottonwood N – KettleCreek S 115 kV
Cottonwood N - KettleCreek S 115 kV	Line	CSU	162/180	155.9	96.3%/86.6%	158	97.7%/87.9%	1.4%	Brairgate S-CottonWood S 115 kV
Monumnet – Flyhorse N 115 kV	Line	CSU	120/120	100	83.1%/83.1%	103	85.6%/85.6%	2.5%	BLk SQMV- Jackson Fuller 115 kV Line



Table 7 – Summary Listing of Differentially Overloaded Facilities DC Tie Importing at 101 MW (Boone 230 kV Substation POI) Without Palmer Lake Series Reactor. % Change calculated based on Normal Ratings.

				Branch N-1 Loading Without GI-2013-1		Branch N-1 Loading With GI-2013-1			
Monitored Facility (Line or Transformer)	Type	Owner	Branch Rating MVA (Norm/Emer)	N-1 Flow MVA	N-1 Flow % of Rating	N-1 Flow MVA	N-1 Flow % of Rating	% Change	NERC Cat C Contingency
Airport Park – Baculite 115 kV	Line	BHCE	195/195	198.3	101.7%/101.7%	200.5	102.8%/102.8%	1.1%	Baculite Mesa – West Station 115 kV # 1& 2
Baculite – NorthRidge 115 kV	Line	BHCE	119/119	124.6	104.7%/104.7%	127.3	106.9%/106.9%	2.2%	Baculite Mesa – West Station 115 kV # 1& 2
Daniels Park – SantaFe 230 kV	Line	PSCo	319/319	313.8	98.4%/98.4%	324	101.6%/101.6%	3.2%	Daniels Park – Prairie – Greenwood 230 kV #1&2
Daniels Park – Jackson Fuller 230 kV	Line	PSCo	478/478	541.9	113.4%/113.4%	564.9	118.2%/118.2%	4.8%	Comanche – Daniels Park 345 kV #1 & 2
Fountain Valley – Desert Cove 115 kV	Line	BHCE	115/115	176.8	153.7%/153.7%	186.2	161.9%/161.9%	8.2%	MidwayBR-MidwayPS-Fuller 230 kV
Fountain Valley – Midway BR 115 kV	Line	BHCE	115/115	175.3	152.5%/152.5%	184.8	160.7%/160.7%	8.2%	MidwayBR-MidwayPS-Fuller 230 kV
Desert Cov – West Station 115 kV	Line	BHCE	120/120	199.5	166.2%/166.2%	208.9	174.1%/174.1%	7.9%	MidwayBR-MidwayPS-Fuller 230 kV
Midway BR – Midway PS 230 kV	Line	PSCo	430/478	446.6	103.9%/93.4%	469.3	109.1%/98.2%	5.2%	Comanche – daniels Park 345 kV #1&2
HydePark – West Station 115 kV	Line	BHCE	119/119	117.8	99%/99%	121.2	101.8%/101.8%	2.8%	Comanche – daniels Park 345 kV #1&2
Midway PS 230/115 kV	Xfmr	PSCo	97/97	92.7	95.6%/95.6%	96.3	99.3%/99.3%	3.7%	Comanche – daniels Park 345 kV #1&2
Pueblo Plant – Reader 115 kV	Line	PSCo	160/160	159.6	99.7%/99.7%	163.2	102%/102%	2.3%	Comanche – daniels Park 345 kV #1&2
Midway BR – Rancho 115 kV	Line	CSU	92/92	93.1	101.2%/101.2%	95.9	104.2%/104.2%	3%	Comanche – daniels Park 345 kV #1&2
Rancho – Lorson Ranch 115 kV	Line	CSU	92/92	91.3	99.2%/99.2%	94	102.2%/102.2%	3%	Comanche – daniels Park 345 kV #1&2
Palmer Lake – Monument 115 kV	Line	CSU/PS Co	120/120	165.3	137.8%/137.8%	173.1	144.3%/144.3%	6.5%	Midway - Waterton 345 kV & Daniels park – Jackson Fuller 230 kV
Cottonwood N – Kettle Creek	Line	CSU	162/180	165.2	102%/91.8%	170.5	105.2%/94.7%	3.2%	Midway - Waterton 345 kV &

				Branch N-1 Loading Without GI-2013-1		Branch N-1 Loading With GI-2013-1			
Monitored Facility (Line or Transformer)	Type	Owner	Branch Rating MVA (Norm/Emer)	N-1 Flow MVA	N-1 Flow % of Rating	N-1 Flow MVA	N-1 Flow % of Rating	% Change	NERC Cat C Contingency
S 115 kV									Daniels park – Jackson Fuller 230 kV
Monument – Flyhorse N 115 kV	Line	CSU	120/120	178.2	148.5%/148.5%	186.2	155.1%/155.1%	6.6%	Midway - Waterton 345 kV & Daniels park – Jackson Fuller 230 kV
Flyhorse S – Kettle Creek N 115 kV	Line	CSU	162/180	188.7	116.5%/104.8%	196.6	121.4%/109.2%	4.9%	Midway - Waterton 345 kV & Daniels park – Jackson Fuller 230 kV
Brairgate S – Cottonwood S 115 kV	Line	CSU	150/192	178.2	118.8%/92.8%	181.1	120.7%/94.3%	1.9%	Cotton Wood North 115 kV Bus outage
MidwayBR 230/115 kV	Xfmr	WAPA	100/120	100.5	100.5%/83.8%	101.5	101.5%/84.6%	1%	Rd Nixon-MidwayBR & RDNixon – Front Range
BLKFORTP – BLK SQMV 115 kV	Line	CSU	81/81	126.1	155.7%/155.7%	128.4	158.5%/158.5%	2.8%	Cottonwood 115 kV tie outage
BLK SQMV – Fuller 115 kV	Line	CSU	143/143	149	104.2%/104.2%	151.4	105.8%/105.8%	1.6%	Cottonwood 115 kV tie outage

Table 8- Generation Dispatch of Major Generating Units in the Study area (MW is Gross value)

PSCo:

<u>Bus</u>	<u>LF ID</u>	<u>MW</u>
Comanche PV	S1	102
Comanche	C1	360
Comanche	C2	365
Comanche	C3	805
Lamar DC Tie	DC	101.0 Import
Fountain Valley	G1	36
Fountain Valley	G2	36
Fountain Valley	G3	36
Fountain Valley	G4	36
Fountain Valley	G5	36
Fountain Valley	G6	36
Colorado Green	1	68
Colorado Green	2	68
Twin Butte	1	63.8
Jackson Fuller	W1	200
Comanche PV	S1	120
RMEC 1	G1	145
RMEC 2	G2	145
RMEC 3	G3	292
Alamosa CT	G1	17
Alamosa CT	G2	14
Cogentrix	S1	25.5
Greater Sandhil	S1	14.5
Blanca Peak	S1	19.5
SLV Solar	S1	41.6

BHE:

<u>Bus</u>	<u>LF ID</u>	<u>MW</u>
BUSCHWRTG1	G1	3.6
BUSCHWRTG2	G2	3.6
E Canon	G1	0
PP_MINE	G1	0
Pueblo Diesels	G1	0
Pueblo Plant	G1	0
Pueblo Plant	G2	0.0
R.F. Diesels	G1	0.0
Airport Diesels	G1	0.0
Canyon City	C1	0
Canyon City	C1	0
Baculite 1	G1	90
Baculite 2	G1	90



Baculite 3	G1	40.0
Baculite 3	G2	40.0
Baculite 3	S1	20
Baculite 4	G1	40.0
Baculite 4	G2	40.0
Baculite 4	S1	21
Baculite 5	G1	90

CSU:

<u>Bus</u>	<u>LF ID</u>	<u>MW</u>
Birdsale1	1	0.0
Birdsale 2	1	0.0
Birdsale 3	1	0.0
Nixon	1	225.39
Tesla	1	24.8
Drake 5	1	49.65
Drake 6	1	83.19
Drake 7	1	141.03
Nixon CT 1	1	0.0
Nixon CT 2	1	0.0
Front Range CC 1	1	120.4
Front Range CC 2	1	120.8
Front Range CC 3	1	120.0