



Feasibility Study Report Generation Interconnection Request # GI-2016-12

80MW Solar Photovoltaic Facility
Boone 115kV Substation
Pueblo County, Colorado

Transmission Planning West
Xcel Energy
September 28, 2016
(DRAFT)

Executive Summary

This report evaluates the feasibility of interconnecting GI-2016-12, an 80MW solar photovoltaic generation facility at the Boone 115kV bus. The generation facility will consist of forty (40) FS2200CU Power Electronic units and 2MVA generation step-up transformers, connecting to one (1) 80MVA main step up transformer. The 80MVA main step-up transformer will interconnect to the Boone 115kV Point of Interconnection (POI) using a Customer owned 115kV tie-line. The Interconnection Customer did not propose a secondary POI. The generation facility is targeted to have a Commercial Operation Date (COD) of December 1, 2018, so the backfeed date is assumed to be June 1, 2018, approximately six months before the COD. The study request is for both Energy Resource Interconnection Service (ERIS) and Network Resource Interconnection Service (NRIS).

The scope of this report includes steady state (power flow) analysis and short circuit analysis. The studies were performed using a Western Electricity Coordinating Council (WECC) approved 2018 heavy summer base case by simulating heavy south-north flow on the Comanche – Midway – Jackson Fuller – Daniels Park study area.

The GI-2016-12 interconnection request was studied as a stand-alone project. That is, the study did not include any other Generator Interconnection Requests (GIR) existing in PSCo's or any affected party's GIR queue, other than the interconnection requests that are considered to be planned resources for which Power Purchase Agreements have been signed.

The affected parties for this study are Colorado Springs Utilities (CSU), Black Hills Colorado Electric (BHCE), Tri-State Generation and Transmission Inc. (TSGT) and Intermountain Rural Electric Association (IREA).

Steady State contingency Analysis Results:

The benchmark case and study case did not have any system intact (P0) thermal and voltage violations.

The results of the single contingency analysis are given in Table-6 and Table-7. The single contingency analysis resulted in the following BHCE facility overload attributable to the interconnection of GI-2016-12.

- Portland – Skala 115kV line loading increased from 99.5% to 104.2%

The results of the multiple contingency analysis are given in Table-8 and Table-9. The study modeled a heavy South – North dispatch in the case, so the mitigation measures for multiple contingency overloads on PSCo will be developed on a discretionary basis if a compelling reliability need is identified. However, the Interconnection Customer will need to work with the affected parties in order to identify mitigation measures to eliminate the following multiple contingency thermal violations attributed to GI-2016-13 interconnection.

The following CSU facility contingency overloads are attributable to the interconnection of GI-2016-13

- Fountain S – RD_Nixon 115kV line loading increased from 121.5% to 122.9%

The following BHCE facility contingency overloads are attributable to the interconnection of GI-2016-13

- HydePark – West Station 115kV line loading increased from 102.2% to 108.1%
- Fountain Valley – DesertCove 115kV line loading increased from 126.8% to 136.2%
- Fountain Valley – MidwayBR 115kV line loading increased from 125.8% to 135.2%
- Pueblo Plant – Reader 115kV line loading increased from 104.2% to 109.6%

The following TSGT facility contingency overloads are attributable to the interconnection of GI-2016-13

- BLKFORTP – BLKSQMV 115 kV line loading increased from 173.1% to 175.7%
- BLK SQMV – Fuller 115kV line loading increased from 112.8% to 114.4%
- Fuller 230/115 kV line loading increased from 127.9% to 129.0%

Short Circuit

The study did not find any over-dutied circuit breakers resulting from GI-2016-12 interconnection.

Conclusion

Energy Resource Interconnection Service (ERIS): GI-2016-12 output for ERIS is 0 MW for the studied generation dispatch scenario due to the single contingency marginal loading on the Portland – Skala 115kV line and the multiple contingency overloads on TSGT, CSU and BHCE facilities seen in the benchmark case. However, higher output may become feasible on an as-available basis depending on the prevailing dispatch of existing generation resources located in the electrical vicinity of GI-2016-12 (Jackson Fuller, Comanche, Midway and Lamar areas).

Network Resource Interconnection Service (NRIS): Implementing the Network Upgrades needed to mitigate the above mentioned thermal overloads on the CSU, TSGT and BHCE facilities will allow GI-2016-12 to achieve full NRIS of 80MW. The Interconnection Customer should work with CSU, TSGT and BHCE in order to identify mitigation measures to eliminate the above mentioned facility overloads.

Cost Estimates (in 2016 dollars)

The total estimated cost of the recommended system improvements to interconnect the project is approximately \$1.182 million and includes:

- \$ 1.087 million for PSCo-Owned, Customer-Funded Transmission Provider Interconnection Facilities
- \$ 0.095 million for PSCo-Owned, PSCo-Funded Network Facilities for Interconnection
- \$ 0 million for PSCo Network Upgrades for Delivery to PSCo Loads

This work can be completed in 18 months following receipt of authorization to proceed. The costs for Network Upgrades on affected party facilities attributed to GI-2016-12 are not included in this report.

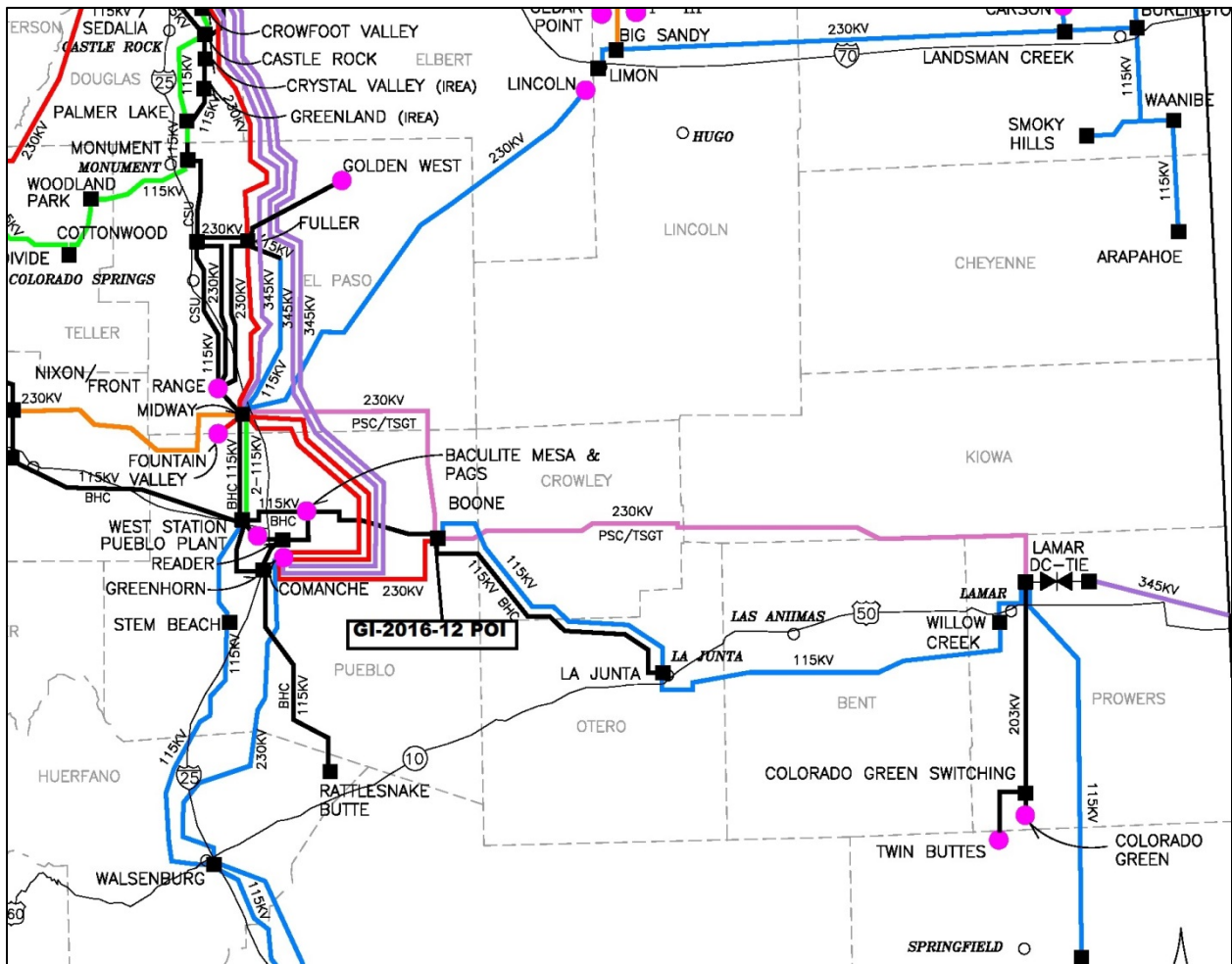

Figure 1 - GI-2016-12 Boone Point of Interconnection and Study Area



Introduction

Public Service Company of Colorado (PSCo) received an 80MW solar photovoltaic generation facility study request (“GI-2016-12”) on June 13, 2016. The Generation Interconnection (GI) facility will include forty (40) Power Electronics model FS2200-US inverters connected to twenty (20) 4 MVA step-up transformers. The twenty (20) step-up transformers will connect to an 80MVA Main Step-up Transformer which will connect to the Point of Interconnection (POI) using an 115kV Customer owned tie-line. The GI facility will be located in Pueblo County, Colorado.

The Primary POI requested by the Interconnection Customer is the Boone 115kV Substation in Pueblo County, Colorado. The Commercial Operation Date (COD) requested by the Customer is December 31, 2018. The Interconnection Customer did not specify a backfeed for GI-2016-12, so it was assumed to be June 31, 2018; six months before the COD.

The Interconnection Customer did not propose a secondary POI.

The Generation interconnection study request is for both Energy Resource Interconnection Service (ERIS) and Network Resource Interconnection Service (NRIS).

Study Scope and Analysis

The scope of this report includes steady state (power flow) analysis and short circuit analysis. The power flow analysis identifies thermal and voltage violations in the PSCo system and the affected party’s system as a result of the addition of GI-2016-12. Several single and multiple contingencies are studied. The short circuit analysis determines the maximum available fault current at the POI. The breaker duty study determines if breaker replacements are needed in the neighboring substations due to the addition of GI-2016-12.

PSCo adheres to applicable NERC Reliability Standards & WECC Reliability Criteria, as well as internal criteria for planning studies. For the steady state analysis the criteria are as follows:

P0 - System Intact conditions:

Thermal Loading: $\leq 100\%$ of the normal facility rating
Voltage range: 0.95 to 1.05 per unit

P1-P2 – Single Contingencies:

Thermal Loading: $\leq 100\%$ Normal facility rating
Voltage range: 0.90 to 1.10 per unit
Voltage deviation: $\leq 5\%$ of pre-contingency voltage

P3-P7– Multiple Contingencies:

Thermal Loading: $\leq 100\%$ Emergency facility rating
Voltage range: 0.90 to 1.10 per unit
Voltage deviation: $\leq 5\%$ of pre-contingency voltage

The thermal and voltage analysis criteria for BHCE facilities are same as above.



The thermal and voltage analysis criteria for CSU facilities are same as above, except that the thermal loading for single contingencies is calculated based on the emergency rating of the facility.

PSCo attempts to maintain a transmission system voltage profile ranging from 1.02 per unit or higher at regulating (generation) buses to 1.0 per unit or higher at transmission load buses.

GI-2016-12 is studied for both Energy Resource Interconnection Service (ERIS) and Network Resource Interconnection Service (NRIS).

Energy Resource Interconnection Service shall mean an Interconnection Service that allows the Interconnection Customer to connect its Generating Facility to the Transmission Provider's Transmission System to be eligible to deliver the Generating Facility's electric output using the existing firm or non-firm capacity of the Transmission Provider's Transmission System on an as available basis. Energy Resource Interconnection Service in and of itself does not convey transmission service.

Network Resource Interconnection Service shall mean an Interconnection Service that allows the Interconnection Customer to integrate its Large Generating Facility with the Transmission Provider's Transmission system (1) in a manner comparable to that in which the Transmission Provider integrates its generating facilities to serve native load customers; or (2) in an RTO or ISO with market based congestion management, in the same manner as all other Network Resources. Network Resource Interconnection Service in and of itself does not convey transmission service.

The affected parties for this GI study are Colorado Springs Utilities (CSU), Black Hills Colorado Electric (BHCE), Tri-State Generation and Transmission Inc. (TSGT) and Intermountain Rural Electric Association (IREA).

Power Flow Study Models

The study was performed using the Western Electricity Coordinating Council (WECC) 2018HS3 power flow case released on 02/02/2016. The case was updated to include the 75MW Twin Buttes generation expansion (in-service date 12/2018), 30MW San Isabel Solar generator interconnected on the Ludlotap – Pinoncanyon 115kV line, replacement of Lamar 230/115kV #T1 with 150MVA unit (expected in-service date 12/2018) and Drake#5 generator retirement.

The generation dispatch in the WECC base case was adjusted to create a heavy south to north flow on the Comanche – Midway - Jackson Fuller – Daniels Park study area. This was accomplished by adopting the generation dispatch given in Table-9 below. PSCo's generation in zones 700, 704, 709, 710 and 712 was dispatched such that wind generation is at 85% name plate capacity, solar generation is at 80% name plate capacity, conventional non-coal generation is at 90% name plate capacity and, coal generation is dispatched at 100% name plate capacity. For BHCE, Baculite Mesa units are dispatched at 100% name plate rating and the remaining generation is dispatched at Rattlesnake Wind (recommended by BHCE because of the Boone POI).

The generation dispatch for CSU loads was provided by CSU.



The Lamar DC tie, the Colorado Green and Twin Buttes wind generators are dispatched such that the total combined injection at Lamar 230kV bus was 350MW.

The GI-2016-12 interconnection request was studied as a stand-alone project. That is, the study did not include any other Generator Interconnection Requests (GIR) existing in PSCo's or an affected party's GIR queue, other than the GIRs that are considered to be planned resources for which Power Purchase Agreements have been signed.

Two power flow cases were created for evaluating the feasibility of GI-2016-12 – the benchmark case and the study case. The benchmark case modeled the system without GI-2016-12, whereas the study case included GI-2016-12. The GI was modeled using the PSSE modeling data provided by the Interconnection Customer. The modeling data provided by the Customer resulted in a total injection of 76MW at the Boone 115kV bus after losses, so the Pmax of the generator is increased such that the total injection at Boone 115kV is 80MW, consistent with the study request. PSCo's Fort Saint Vrain #1 unit is used as the sink for the 80MW generation injection of GI-2016-12.

Power Flow Study Process

The steady state analysis was performed using PTI's PSSE Ver. 33.6.0 program and the ACCC contingency analysis tool. Contingencies were performed in accordance with NERC Standard TPL-001-4. These are described below.

The analysis was performed for P0, P1, P2, P4 and P7 contingencies. The P3, P5 and P6 contingencies were not run; Instead, the P4 and P7 contingencies were run which are worse case.

- The P0 analysis was done on all of area 70.
- The P1 single contingencies were run on zones 121, 700, 703, 704, 705, 709, 710, 712, 752 and 757.
- The P2 single contingencies were run on all of area 70, area 73 and zone 121.
- The P4 and P7 contingencies were run on zones 121, 700, 703, 704, 705, 709, 710, 712, 752 and 757.

The power flow study process described above is summarized in the table below.

Table 01 – TPL-001-4 Transmission Planning Performance Requirements Simulated

Category	Description	Initial Condition	Event	Interruption of Firm Transmission Service Allowed?	Non-consequential Load Loss Allowed?	Areas Analyzed	Zones Analyzed
P0	No Contingency	Normal System	None	No	No	70	
P1	Single Contingency	Normal System	Loss of generator, branch, transformer, shunt device	No	No		121, 700, 703, 704, 709, 710, 712, 752, 757
P2	Single Contingency	Normal System	Open line section w/o fault, bus section fault, internal breaker	Sometimes	Sometimes	70, 73	121

			faults				
P3	Multiple Contingency	Loss of Gen followed by system adjustment	Loss of generator, branch, transformer, shunt device	No	No		
P4	Multiple Contingency (Fault + stuck breaker)	Normal System	Loss of multiple elements from stuck breaker clearing a fault	Sometimes	Sometimes		121, 700, 703, 704, 709, 710, 712, 752, 757
P5	Multiple Contingency (Fault + relay failure)	Normal System	Delayed fault clearing due to failure of non-redundant relay protecting a faulted element	Sometimes	Sometimes		121, 700, 703, 704, 709, 710, 712, 752, 757
P6	Multiple Contingency (Two overlapping singles)	Loss of branch, transformer, shunt device followed by system adjustment	Loss of branch, transformer, shunt device	Yes	Yes		
P7	Multiple Contingency (Common structure)	Normal System	Loss of any two adjacent (vertically or horizontally) circuits on a common structure	Yes	Yes		121, 700, 703, 704, 709, 710, 712, 752, 757

The same list of contingencies was run on the benchmark case and the study case, and the results were compared.

For PSCo facilities - thermal violations attributable to the GI-2016-13 interconnection included any facilities without a pre-existing thermal violation but resulted in a thermal loading >100% post GI-2016-13 interconnection and contributed to a 2% increase in the facility loading compared to the benchmark case loading. Pre-existing thermal violations in the benchmark case are attributable to the GI-2016-13 interconnection if the planned PSCo upgrade is insufficient to mitigate the (increased) thermal violation in the study case. In such case, only the additional facility rating increase (beyond the PSCo planned uprate) required to accommodate the NRIS will be attributed to GI-2016-13.

The voltage violations attributed to GI-2016-13 included any new voltage range and voltage deviation violations.

The Interconnection Customer should work with the affected parties in order to find mitigation measures for any existing and new thermal overloads on non-PSCo facilities.

The study area is the electrical system consisting of PSCo's transmission system and the affected party's transmission system that is impacted or that will impact interconnection of GI-2016-12. The study area for GI-2016-12 at the Boone POI include WECC designated zones 121, 700, 703, 704, 705, 709, 710, 712, 752 and 757.

Power Flow Results

Single Contingency Analysis:

The benchmark case and study case did not have any system intact (P0) thermal and voltage violations.

The results of single contingency analysis (P1 and P2) are given in Table-6. The results show that the addition of GI-2016-12 caused new thermal overloads on certain PSCo, BHCE, CSU and TSGT facilities.

The thermal overloads on the CSU facilities were eliminated when the Palmer Lake- Monument 115kV line operating procedure is implemented. The results of the steady state analysis after implementing the Palmer Lake – Monument 115kV line operating procedure are given in Table-7. From the results in Table-7, it is evident that the operating procedure increased the marginal loading on the Daniels Park – Prairie1 230kV line from 99.9% to 100.8%, so Daniels Park – Prairie1 230kV line thermal violation is a pre-existing benchmark case violation. PSCo has a planned project to increase the Daniels Park – Prairie1 230kV line rating in Summer 2017, the new rating of this facility will be adequate to eliminate the study case overload, so this thermal violation is not attributable to GI-2016-12.

The following BHCE facility overload is attributable to the interconnection of GI-2016-12.

- Portland – Skala 115kV line loading increased from 99.5% to 104.2%

The Interconnection Customer will need to work with BHCE to identify the network upgrades required to mitigate the overload on the Portland-Skala 115kV line.

Addition of GI-2016-12 did not cause any new voltage violations and increases in the existing voltage violations are small as to not require monitoring. There were no voltage violations attributable to GI-2016-12 addition.

Multiple Contingency Analysis:

The results of the multiple contingency analysis are given in Table-8 and Table-9. The study modeled a heavy South – North dispatch in the case, so the mitigation measures for multiple contingency overloads on PSCo will be developed on a discretionary basis if a compelling reliability need is identified. However, the Interconnection Customer will need to work with the affected parties in order to identify mitigation measures to eliminate the following multiple contingency thermal violations attributed to GI-2016-13 interconnection.

The following CSU facility contingency overloads are attributable to the interconnection of GI-2016-13

- Fountain S – RD_Nixon 115kV line loading increased from 121.5% to 122.9%

The following BHCE facility contingency overloads are attributable to the interconnection of GI-2016-13

- HydePark – West Station 115kV line loading increased from 102.2% to 108.1%
- Fountain Valley – DesertCove 115kV line loading increased from 126.8% to 136.2%
- Fountain Valley – MidwayBR 115kV line loading increased from 125.8% to 135.2%
- Pueblo Plant – Reader 115kV line loading increased from 104.2% to 109.6%

The following TSGT facility contingency overloads are attributable to the interconnection of GI-2016-13

- BLKFORTP – BLKSQMV 115 kV line loading increased from 173.1% to 175.7%
- BLK SQMV – Fuller 115kV line loading increased from 112.8% to 114.4%
- Fuller 230/115 kV line loading increased from 127.9% to 129.0%

Short Circuit

The calculated short circuit levels and Thevenin system equivalent impedances at the Boone 115kV POI are tabulated below.

Table 2 – Short Circuit Parameters at the Boone 115kV POI

System Condition	Three-Phase Fault Level (Amps)	Single-Line-to-Ground Fault Level (Amps)	SLG X/R	3 Phase X/R
Without GI-2016-12	9358	9053	8.248	8.306
With GI-2016-12	9358	9135	8.248	8.306

Conclusion

Energy Resource Interconnection Service (ERIS): GI-2016-12 output for ERIS is 0 MW for the studied generation dispatch scenario due to the single contingency marginal loading on the Portland – Skala 115kV line and the multiple contingency overloads on TSGT, CSU and BHCE facilities seen in the benchmark case. However, higher output may become feasible on an as-available basis depending on the prevailing dispatch of existing generation resources located in the electrical vicinity of GI-2016-12 (Jackson Fuller, Comanche, Midway and Lamar areas).

Network Resource Interconnection Service (NRIS): Implementing the Network Upgrades needed to mitigate the above mentioned thermal overloads on the CSU, TSGT and BHCE facilities will allow GI-2016-12 to achieve full NRIS of 80MW. The Interconnection Customer should work with CSU, TSGT and BHCE in order to identify mitigation measures to eliminate the above mentioned facility overloads.

Costs Estimates and Assumptions

Scoping level cost estimates for Interconnection Facilities and Network/Infrastructure Upgrades for Delivery (+/- 30% accuracy) were developed by PSCo Engineering. The cost estimates are in 2016 dollars with escalation and contingencies applied (AFUDC is not included) and are based upon typical construction costs for previously performed similar construction. These estimated costs include all applicable labor and overheads associated with the siting support, engineering, design, and construction of these new PSCo facilities. This estimate does not include the cost for any other Customer owned equipment and associated design and engineering.

The estimated total cost for the required upgrades is **\$1,182,000**.

Figure 2 below is a conceptual one-line of the proposed interconnection. The Point of Interconnection will be the Boone 115kV Transmission substation.

The following Tables 3-4 list the improvements required to accommodate the interconnection and the delivery of the customer's 80MW solar facility generation output. The cost responsibilities associated with these facilities shall be handled as per current FERC guidelines. System improvements are subject to revision as a more detailed and refined design is produced.

Cost Estimate Assumptions

- Scoping level cost estimates for Interconnection Facilities and Network/Infrastructure Upgrades for Delivery (+/- 30% accuracy) were developed by PSCo Engineering.
- Estimates are based on 2016 dollars (appropriate contingency and escalation applied).
- AFUDC has been excluded.
- Labor is estimated for straight time only – no overtime included.
- Lead times for materials were considered for the schedule.
- The Solar Generation Facility is not in PSCo's retail service territory. Therefore, no costs for retail load metering are included in these estimates.
- PSCo (or it's Contractor) crews will perform all construction, wiring, testing and commissioning for PSCo owned and maintained facilities.
- The estimated time to design, procure and construct the interconnection facilities is approximately 18 months after authorization to proceed has been obtained.
- This project is completely independent of other queued projects and their respective ISD's.
- A CPCN will not be required for the interconnection facilities construction.
- Customer will string OPGW fiber into substation as part of the transmission line construction scope.
- Breaker duty study determined that no breaker replacements are needed in neighboring substations.
- Line and substation bus outages will be necessary during the construction period. Outage availability could potentially be problematic and extend requested backfeed date due.
- Power Quality Metering (PQM) will be required on the Customer's 230 kV line terminating into Boone Substation.
- Network Upgrade costs for affected party facilities are not included in this report

Table 3 – PSCo Owned; Customer Funded Transmission Provider Interconnection Facilities

Element	Description	Cost Est. (Millions)
PSCo's Boone 115kV Transmission Substation	Interconnect Customer to the 115kV bus at the Boone Substation. The new equipment includes: <ul style="list-style-type: none"> • One (1) motor operated 115kV disconnect switch • Three (3) 230kV combination CT/PT metering units • Power Quality Metering (115kV line from Customer) • Three (3) surge arresters • Two (2) relay panels • Associated bus, wiring and equipment • Associated foundations and structures • Associated transmission line communications, relaying and testing 	\$1.037

	Transmission line tap into substation. Conductor, hardware, and installation labor.	\$0.050
	Total Cost Estimate for PSCo-Owned, Customer-Funded Interconnection Facilities	\$1.087
Time Frame	Design, procure and construct	18 Months

Table 4: PSCo Owned; PSCo Funded Interconnection Network Facilities

Element	Description	Cost Estimate (Millions)
PSCo's Boone 115kV Transmission Substation	Interconnect Customer to the 115kV bus at the Boone 115kV Substation. The new equipment includes: <ul style="list-style-type: none"> • One (1) 115kV gang switches • Associated communications, supervisory and SCADA equipment • Associated line relaying and testing • Associated bus, miscellaneous electrical equipment, cabling and wiring • Associated foundations and structures • Associated road and site development, fencing and grounding 	\$0.095
	Siting and Land Rights support for substation land acquisition and construction.	\$0.000
	Total Cost Estimate for PSCo-Owned, PSCo-Funded Interconnection Facilities	\$0.095
Time Frame	Site, design, procure and construct	18 Months

Table 5 – PSCo Network Upgrades for Delivery

Element	Description	Cost Est. (Millions)
	None identified.	\$0.00
	Total Cost Estimate for PSCo Network Upgrades for Delivery	\$0.00
	Design, procure and construct	N/A
	Total Project Estimate	\$1.182



A. Power Flow Contingency Analysis Results

Notes –

1. All thermal loadings are highlighted in yellow and violations are identified in red.
2. For Single Contingency Analysis, thermal overloads on:
 - PSCo facilities are calculated using the applicable Normal Rating.
 - CSU facilities are calculated using the applicable Emergency Rating.
3. For Multiple Contingency Analysis, thermal overloads on All facilities are calculated using applicable Emergency Rating of the facility

**Table 6 – Summary of thermal violations from Single Contingency Analysis
Without Palmer Lake– Monument 115kV Line Operating Procedure**

				Facility Loading Without GI-2016-12		Facility Loading With GI-2016-12			
Monitored Facility (Line or Transformer)	Type	Owner	Branch Rating MVA (Norm/Emer)	N-1 Flow MVA	N-1 Flow % of Rating	N-1 Flow MVA	N-1 Flow % of Rating	% Change	NERC Single Contingency
Daniels Park – Prairie1 230kV	Line	PSCo	478/478	477.5	99.9%/99.9%	496.6	103.9%/103.9%	4.0%	Daniels Park – Prairie3 230kV Line
Portland – Skala 115kV	Line	BHCE	111/111	108.7	97.9%/97.9%	113.8	102.5%/102.5%	4.6%	MidwayBR – West Canyon 230kV
Brairgate S – Cottonwood S 115kV	Line	CSU	150/192	175.7	117.1%/91.5%	179.9	119.9%/93.7%	2.2%	Cottonwood N - KettleCreek S 115kV
Cottonwood N - KettleCreek S 115kV	Line	CSU	162/180	190.9	117.9%/106.1%	195.9	120.9%/108.8%	2.7%	Brairgate S – Cottonwood S 115kV
Monument – Flyhorse N 115kV	Line	CSU	142/157	138.6	97.6%/88.3%	145.9	102.8%/92.9%	4.6%	Daniels Park – Jackson Fuller 230kV
BLKFORTP – BLK SQMV 115kV	Line	TSGT	81/81	84.5	104.3%/104.3%	88.1	108.8%/108.8%	4.5%	Flyhorse S – Kettlecreek N 115kV
Fuller 230/115kV	Xfmr	TSGT	100/100	100	100.0%/100.0%	101	101.0%/101.0%	1%	MidwayBR – Rancho 115kV

Notes –

1. All thermal loadings are highlighted in yellow and violations are identified in red.
2. For Single Contingency Analysis, thermal overloads on:
 - PSCo facilities are calculated using the applicable Normal Rating.
 - CSU facilities are calculated using the applicable Emergency Rating.
3. For Double Contingency Analysis, thermal overloads on All facilities are calculated using applicable Emergency Rating of the facility

**Table 7 – Summary of thermal violations from Single Contingency Analysis
With Palmer Lake – Monument 115kV Line Operating Procedure**

				Facility Loading Without GI-2016-12		Facility Loading With GI-2016-12			
Monitored Facility (Line or Transformer)	Type	Owner	Branch Rating MVA (Norm/Emer)	N-1 Flow MVA	N-1 Flow % of Rating	N-1 Flow MVA	N-1 Flow % of Rating	% Change	NERC Single Contingency
Daniels Park – Prairie1 230kV	Line	PSCo	478/478	481.8	100.8%/100.8%	501.4	104.9%/104.9%	4.1%	Daniels Park – Prairie3 230kV Line
Portland – Skala 115kV	Line	BHCE	111/111	110.4	99.5%/99.5%	115.7	104.2%/104.2%	4.7%	MidwayBR – West Canyon 230kV
Brairgate S – Cottonwood S 115kV	Line	CSU	150/192	140.1	93.4%/72.9%	141.8	94.5%/73.8%	0.9%	Cottonwood N - KettleCreek S 115kV
Cottonwood N - KettleCreek S 115kV	Line	CSU	162/180	147.7	91.2%/82.1%	149.7	92.4%/83.2%	1.1%	Brairgate S – Cottonwood S 115kV
Monument – Flyhorse N 115kV	Line	CSU	142/157	65.6	46.2%/41.8%	68.3	48.1%/43.5%	1.7%	Daniels Park – Jackson Fuller 230kV
BLKFORTP – BLK SQMV 115kV	Line	TSGT	81/81	68.8	85.0%/85.0%	70.8	87.4%/87.4%	2.4%	Flyhorse S – Kettlecreek N 115kV
Fuller 230/115kV	Xfmr	TSGT	100/100	86.9	86.9%/86.9%	87.1	87.1%/87.1%	0.2%	MidwayBR – Rancho 115kV



Notes –

1. All thermal violations are identified in red.
2. For Single Contingency Analysis, thermal overloads on:
 - PSCo facilities are calculated using the applicable Normal Rating.
 - CSU facilities are calculated using the applicable Emergency Rating.
3. For Multiple Contingency Analysis, thermal overloads on All facilities are calculated using applicable Emergency Rating of the facility

**Table 8 – Summary of thermal violations from Multiple Contingency Analysis
Without Palmer Lake– Monument 115kV Line Operating Procedure**

Monitored Facility (Line or Transformer)	Type	Owner	Branch Rating MVA (Norm/Emer)	Facility Loading Without GI-2016-12		Facility Loading With GI-2016-12		% Change	NERC Multiple Contingency
				Flow MVA	Flow % of Rating	Flow MVA	Flow % of Rating		
Daniels Park – SantaFe 230kV	Line	PSCo	319/319	332.4	104.2%/104.2%	345.5	108.3%/108.3%	4.1%	Double Ckt: Daniels Park – Prairie – Greenwood 230kV 1&2
Daniels Park – Fuller 230kV	Line	PSCo	478/478	585.6	122.5%/122.5%	622.4	130.2%/130.2%	7.7%	Double Ckt: Daniels Park – Comanche 345 kV 1&2
HydePark – West Station 115kV	Line	BHCE	120/120	122.2	101.8%/101.8%	125.8	104.8%/104.8%	3.0%	Double Ckt: Daniels Park – Comanche 345 kV 1&2
MidwayPS 230/115kV#T1	Xfmr	PSCo	97/120	112.0	115.5%/93.4%	121.4	125.2%/101.2%	7.8%	Double Ckt: Daniels Park – Comanche 345 kV 1&2
Fountain Valley – DesertCove 115kV	Line	BHCE	119/119	150.9	126.8%/126.8%	162.1	136.2%/136.2%	9.4%	Breaker Failure: MidwayBR 230kV Sub & MidwayPS – J.Fuller 230kV
Fountain Valley – MidwayBR 115kV	Line	BHCE	119/119	149.7	125.8%/125.8%	160.9	135.2%/135.2%	9.4%	Breaker Failure: MidwayBR 230kV Sub & MidwayPS – J.Fuller 230kV
Portland – Skala 115kV	Line	BHCE	111/111	115.2	103.8%/103.8%	121.1	109.1%/109.1%	5.3%	Breaker Failure: MidwayBR 230kV Sub & MidwayPS – J.Fuller 230kV
Midway 230kV Bus tie	Line	PSCo/ WAPA	430/478	565.0	131.4%/118.2%	595.1	138.4%/124.5%	6.3%	Double Ckt: MidwayPS – Waterton 345kV & MidwayPS – J. Fuller 230kV
Waterton – Martin1 Tap 115kV	Line	PSCo	138/142	139.7	101.2%/98.3%	142.1	103%/100%	1.7%	Double Ckt: Sodalake – Waterton 230kV & Sodalake – Waterton 115kV
Palmer Lake – Monument 115kV	Line	PSCo/C SU	142/157	182.7	128.7%/116.4%	193.5	136.3%/123.3%	6.9%	Double Ckt: MidwayPS – Waterton 345kV & Daniels Park – J. Fuller 230kV
Cottonwood N – Kettle Creek S 115kV	Line	CSU	162/180	187.8	115.9%/104.3%	195.2	120.5%/108.5%	4.2%	Double Ckt: MidwayPS – Waterton 345kV & Daniels Park – Fuller 230kV

**Table 8 – Summary of thermal violations from Multiple Contingency Analysis
Without Palmer Lake– Monument 115kV Line Operating Procedure**

				Facility Loading Without GI-2016-12		Facility Loading With GI-2016-12			
Monitored Facility (Line or Transformer)	Type	Owner	Branch Rating MVA (Norm/Emer)	Flow MVA	Flow % of Rating	Flow MVA	Flow % of Rating	% Change	NERC Multiple Contingency
Monument – Flyhorse N 115kV	Line	CSU	142/157	204.3	143.9%/130.1%	215.1	151.5%/137.0%	6.9%	Double Ckt: MidwayPS – Waterton 345kV & Daniels Park – Fuller 230kV
Flyhorse S – Kettle Creek N 115kV	Line	CSU	162/180	215.6	133.1%/119.8%	226.5	139.8%/125.8%	6.0%	Double Ckt: MidwayPS – Waterton 345kV & Daniels Park – Fuller 230kV
BLKFORTP – BLK SQMV 115kV	Line	TSGT	81/81	129.2	159.5%/159.5%	132.7	163.8%/163.8%	4.3%	Breaker Failure: Cottonwood 115kV Tie
BLK SQMV – Fuller 115kV	Line	TSGT	143/143	150.4	105.2%/105.2%	154.0	107.7%/107.7%	2.5%	Breaker Failure: Cottonwood 115kV Tie
Fuller 230/115 kV	Line	TSGT	100/100	127.9	127.9%/127.9%	129	129.0%/129.0%	1.1%	Breaker Failure: Cottonwood 115kV Tie
Fountain S – RD_Nixon 115 kV	Line	CSU	195/212	257.6	132.1%/121.5%	260.7	133.7%/122.9%	1.4%	Breaker Failure: Kelker 230kV Tie

Notes –

1. All thermal violations are identified in red.



2. For Single Contingency Analysis, thermal overloads on:
 - PSCo facilities are calculated using the applicable Normal Rating.
 - CSU facilities are calculated using the applicable Emergency Rating.
3. For Multiple Contingency Analysis, thermal overloads on All facilities are calculated using applicable Emergency Rating of the facility

**Table 9 – Summary of thermal violations from Multiple Contingency Analysis
With Palmer Lake– Monument 115kV Line Operating Procedure**

Monitored Facility (Line or Transformer)	Type	Owner	Branch Rating MVA (Norm/Emer)	Facility Loading Without GI-2016-12		Facility Loading With GI-2016-12		% Change	NERC Multiple Contingency
				Flow MVA	Flow % of Rating	Flow MVA	Flow % of Rating		
Daniels Park – SantaFe 230kV	Line	PSCo	319/319	334.6	104.9%/104.9%	347.7	109.0%/109.0%	4.1%	Double Ckt: Daniels Park – Prairie – Greenwood 230kV 1&2
Daniels Park – Fuller 230kV	Line	PSCo	478/478	663.5	138.8%/138.8%	715.6	149.7%/149.7%	10.9%	Double Ckt: Daniels Park – Comanche 345 kV 1&2
HydePark – West Station 115kV	Line	BHCE	120/120	122.6	102.2%/102.2%	129.7	108.1%/108.1%	5.9%	Double Ckt: Daniels Park – Comanche 345 kV 1&2
MidwayPS 230/115kV#T1	Xfmr	PSCo	97/120	111.6	115.1%/93.0%	121.1	124.8%/100%	7.0%	Double Ckt: Daniels Park – Comanche 345 kV 1&2
Fountain Valley – DesertCove 115kV	Line	BHCE	119/119	147.2	123.7%/123.7%	157.9	132.7%/132.7%	9.0%	Breaker Failure: MidwayBR 230kV Sub & MidwayPS – J.Fuller 230kV
Fountain Valley – MidwayBR 115kV	Line	BHCE	119/119	146.0	122.7%/122.7%	156.7	131.7%/131.7%	9.0%	Breaker Failure: MidwayBR 230kV Sub & MidwayPS – J.Fuller 230kV
Portland – Skala 115kV	Line	BHCE	111/111	115.7	104.2%/104.2%	121.7	109.6%/109.6%	5.4%	Breaker Failure: MidwayBR 230kV Sub & MidwayPS – J.Fuller 230kV
Midway 230kV Bus tie	Line	PSCo/ WAPA	430/478	543.1	126.3%/113.6%	571.9	133.0%/119.6%	6.0%	Double Ckt: MidwayPS – Waterton 345kV & MidwayPS – J. Fuller 230kV
Waterton – Martin1 Tap 115kV	Line	PSCo	138/142	138.1	100.1%/97.3%	140.5	101.8%/98.9%	1.6%	Double Ckt: Sodalake – Waterton 230kV & Sodalake – Waterton 115kV
Palmer Lake – Monument 115kV	Line	PSCo/C SU	142/157	N/A	N/A	N/A	N/A	N/A	Double Ckt: MidwayPS – Waterton 345kV & Daniels Park – J. Fuller 230kV
Cottonwood N – Kettle Creek S 115kV	Line	CSU	162/180	113.9	70.3%/63.3%	117.3	72.4%/65.2%	1.9%	Double Ckt: MidwayPS – Waterton 345kV & Daniels Park – Fuller 230kV
Monument – Flyhorse N 115kV	Line	CSU	142/157	96	67.6%/61.1%	100.5	70.8%/64.0%	2.9%	Double Ckt: MidwayPS – Waterton 345kV & Daniels Park – Fuller 230kV

**Table 9 – Summary of thermal violations from Multiple Contingency Analysis
With Palmer Lake– Monument 115kV Line Operating Procedure**

Monitored Facility (Line or Transformer)	Type	Owner	Branch Rating MVA (Norm/Emer)	Facility Loading Without GI-2016-12		Facility Loading With GI-2016-12		% Change	NERC Multiple Contingency
				Flow MVA	Flow % of Rating	Flow MVA	Flow % of Rating		
Flyhorse S – Kettle Creek N 115kV	Line	CSU	162/180	107.2	66.2%/59.6%	111.8	69.0%/62.1%	2.5%	Double Ckt: MidwayPS – Waterton 345kV & Daniels Park – Fuller 230kV
BLKFORTP – BLK SQMV 115kV	Line	TSGT	81/81	140.2	173.1%/173.1%	142.7	175.7%/175.7%	2.6%	Breaker Failure: Cottonwood 115kV Tie
BLK SQMV – Fuller 115kV	Line	TSGT	143/143	161.3	112.8%/112.8%	163.6	114.4%/114.4%	1.6%	Breaker Failure: Cottonwood 115kV Tie
Fuller 230/115 kV	Line	TSGT	100/100	136.8	136.8%/136.8%	136.9	136.9%/136.9%	0.1%	Breaker Failure: Cottonwood 115kV Tie
Fountain S – RD_Nixon 115 kV	Line	CSU	195/212	251.6	129.0%/118.7%	254.1	130.3%/119.8%	1.1%	Breaker Failure: Kelker 230kV Tie

Table 9 – Generation Dispatch in the Study area (MW is Gross Capacity)

PSCo:

<u>Bus</u>	<u>LF ID</u>	<u>MW</u>
Comanche PV	S1	102
Comanche	C1	357
Comanche	C2	365
Comanche	C3	795
Lamar DC Tie	DC	100
Fountain Valley	G1	36
Fountain Valley	G2	36
Fountain Valley	G3	36
Fountain Valley	G4	36
Fountain Valley	G5	36
Fountain Valley	G6	36
Colorado Green	1	64.8
Colorado Green	2	64.8
Twin Butte	1	60
Twin Butte-II	W1	60
Jackson Fuller	W1&W2	199.9
Alamosa CT	G1	15.3
Alamosa CT	G2	12.6
Cogentrix	S3	25.5
Greater Sandhill	S1	16.1
Blanca Peak	S1	19.5
SLV Solar	S1	44.2

BHE:

<u>Bus</u>	<u>LF ID</u>	<u>MW</u>
BUSCHWRTG1	G1	23.0
BUSCHWRTG2	G2	23.0
BUSCHWRTG2	G3	23.0
E Canon	G1	0
PP_MINE	G1	0
PuebloDiesels	G1	0
Pueblo Plant	G1	0
Pueblo Plant	G2	0.0
R.F. Diesels	G1	0.0
Airport Diesels	G1	0.0
Canyon City	C1	0
Canyon City	C1	0
Baculite 1	G1	90
Baculite 2	G1	90
Baculite 3	G1	40.0
Baculite 3	G2	40.0
Baculite 3	S1	21
Baculite 4	G1	40.0



Baculite 4	G2	40.0
Baculite 4	S1	21
Baculite 5	G1	0

CSU:

<u>Bus</u>	<u>LF ID</u>	<u>MW</u>
Birdsale1	1	0.0
Birdsale 2	1	0.0
Birdsale 3	1	0.0
RD_Nixon	1	220.9
Tesla	1	13.2
Drake 5	1	0.0
Drake 6	1	81.6
Drake 7	1	138.2
Nixon CT 1	1	0.0
Nixon CT 2	1	0.0
Front Range CC 1	1	142.6
Front Range CC 2	1	142.6
Front Range CC 3	1	141.9

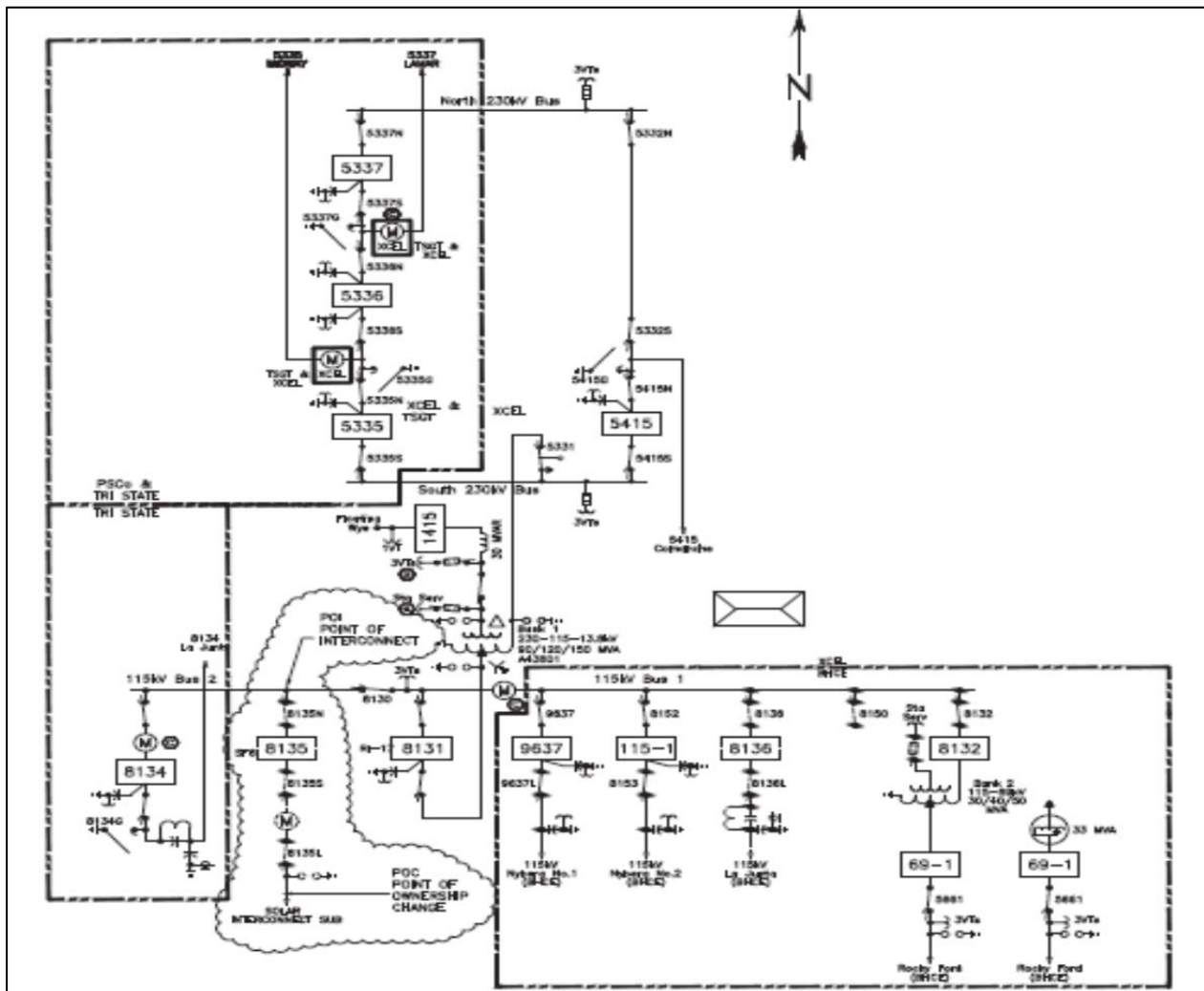

Figure 2 – GI-2016-12 Conceptual One-Line Diagram of the POI