



# Interconnection Feasibility Study Report Request # GI-2016-14

**Final**

500 MW Wind Generating Facility  
Missile Site 345 kV Substation, Colorado

Public Service Company of Colorado  
Transmission Planning  
February 2, 2017

## **Executive Summary**

Public Service Company of Colorado (PSCo) received an Interconnection Request (IR) on July 11, 2016 which was assigned GI-2016-14 queue position. GI-2016-14 is a wind generating facility rated at 500 MW gross electrical output that will be located in Cheyenne County Colorado. The wind facility would connect to the transmission system at the end of the Missile Site – Rush Creek 345 kV line, which is also referred to as the Rush Creek II site. However, the point of interconnection (POI) for GI-2016-14 is the 345 kV bus within the Missile Site Substation, which is the point at which power from the wind facility is delivered to the PSCo system.

The proposed 500 MW generating facility is expected to consist of approximately 250 wind turbine generators, where each turbine is rated 2.0 MW and is equipped with a 0.69/34.5 kV step-up transformer. Preliminary information on the wind generating facility's layout suggests that the 250 WTGs will be grouped together into two 34.5 kV collector systems, and each 34.5 kV collector system will connect to 34.5/345 kV main step-up transformers (MST). The two MSTs will connect to the Rush Creek II site via a 55 mile 345 kV line. The facility will ultimately connect to the Missile Site POI through the Rush Creek Gen-Tie, which is an 85 mile, 345 kV radial transmission line that is expected to be constructed by October 2018.

Figure 1 below is a conceptual one-line diagram of the proposed POI and physical connection location for GI-2016-14 and the surrounding transmission system.

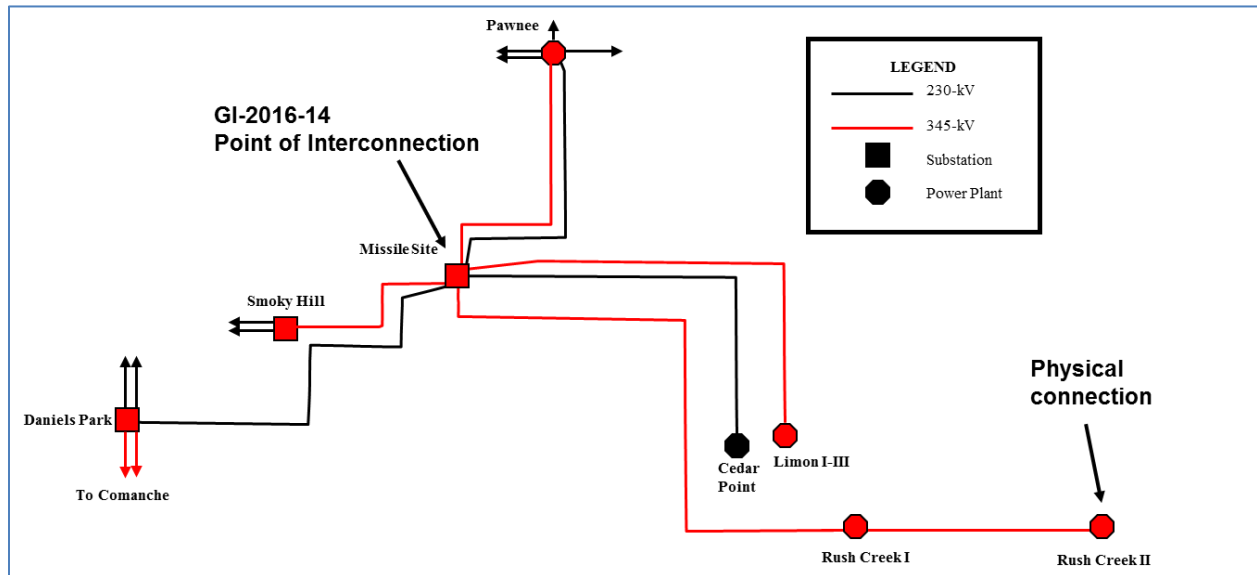

**Figure 1: Missile Site and Surrounding Transmission System**

The Commercial Operation Date (COD) requested for the generating facility is October 1, 2019. Based on the requested COD, the assumed back-feed date for the facility is April 1, 2019 (approximately six months before the COD). The IR indicated that this Feasibility Study should include studies for both Network Resource Interconnection Service (NRIS) and Energy Resource Interconnection Service (ERIS).

The purpose of this Feasibility Study is to determine the feasibility of aggregate injection at the Missile Site 345 kV POI (for delivery to PSCo network loads) resulting from the proposed 500 MW output of GI-2016-14 in addition to the planned 600 MW output from GI-2016-3, which has the same POI, was assumed to be in service and in the models. Towards this purpose, the study also identifies the transmission improvements needed to enable delivery of the combined 1100 MW electrical output to PSCo network loads – that is, for GI-2016-14 to qualify as NRIS.

The Feasibility Study consisted of steady state (power flow) and short-circuit analyses. The power flow analyses were performed using two power flow models developed for GI-2016-14, both of which are based on the WECC 2021 heavy summer (2021HS) base case. The two power flow models are:

- a Benchmark Case which models the transmission system prior to the GI-2016-14 interconnection (Before GI-2016-14 case). This model includes the planned generator interconnection at the same POI (GI-2016-3) and the planned 2021 transmission system topology, which includes the Pawnee – Daniels Park 345 kV project.
- a Study Case that includes the 500 MW generation under study (i.e. After GI-2016-14 case).



The Pawnee – Daniels Park 345 kV project<sup>1</sup> is a PSCo planned project for which the Colorado Public Utility Commission (CPUC) has approved a Certificate of Public Convenience and Necessity (CPCN) and has an in-service date of October 31, 2019. Studies for GI-2016-3 demonstrated that the Pawnee – Daniels Park project was needed to deliver the 600 MW to the PSCo system. Therefore, that project was included in the power flow models.

There are no facilities belonging to other entities in the immediate vicinity of the interconnection and the studies indicated that there were no adverse impacts to other systems. However, Tri-State Generation and Transmission Association (Tri-State) has requested to be included as an “affected party”, for interconnections at or near the Rush Creek project, due to the proximity of their transmission system. Therefore, Tri-State is an affected party for GI-2016-14.

This Feasibility Study showed that the additional 500 MW generation injection into Missile Site Substation has the potential to overload the Greenwood – Monaco 230 kV line following the loss of the Smoky Hill – Leetsdale 230 kV line. Results are shown in the power flow analysis results provided in Table A.1 in the Appendix (see page 12). Therefore, a new network upgrade is required for the proposed GI-2016-14 interconnection to achieve 500 MW NRIS<sup>2</sup>. The network upgrade consists of replacing limiting substation equipment to increase the thermal rating of the Greenwood – Monaco 230 kV line.

Consequently this Feasibility Study concludes that the GI-2016-14 interconnection would achieve 500 MW NRIS (in addition to the 600 MW NRIS of GI-2016-3) provided the Pawnee – Daniels Park 345 kV project is in service, and the identified Greenwood – Monaco 230 kV network upgrades are implemented.

Therefore, for GI-2016-14 interconnection:

NRIS (before network upgrades) = 0 MW

ERIS (before network upgrades) = 0 to 500 MW on “as-available” basis

NRIS and/or ERIS (after network upgrades) = 500 MW

Assuming the Interconnection Facilities and Network Upgrades for GI-2016-3 are in-service, transmission improvements are needed for the interconnection and delivery of GI-2016-14 generation output as NRIS. As shown in **Tables 1–2**, the cost for the Interconnection Facilities and the Network Upgrades for Delivery is **\$14.057 million** and includes:

- \$14.035 million for PSCo-Owned, Interconnection Customer Funded Interconnection Facilities

<sup>1</sup> More information at: <http://www.transmission.xcelenergy.com/Projects/Colorado>

<sup>2</sup> Network Resource Interconnection Service allows Interconnection Customer 's Large Generating Facility to be designated as a Network Resource, up to the Large Generating Facility's full output, on the same basis as existing Network Resources interconnected to Transmission Provider's Transmission System, and to be studied as a Network Resource on the assumption that such a designation will occur. (*section 3.2.2 of Attachment N in Xcel Energy OATT*)



- \$0.022 million for PSCo Network Upgrades for Delivery to PSCo Loads

It is estimated that this work can be completed in approximately 48 months, following receipt of authorization to proceed. The schedule assumes a Certificate of Public Convenience and Necessity (CPCN) for the 345 kV substation at the Rush Creek II site would be required.

### **Power Flow N-1 Contingency Analysis**

The 2021HS base case was updated to dispatch the existing and planned generation within the Pawnee and Missile Site “generation pockets” (i.e. aggregate of generation in the local area) at their respective highest coincident output deemed appropriate for the planning of adequate transmission capacity. This was done in accordance with the generation dispatch assumptions practiced by PSCo Transmission Planning function to study the feasibility and system impact of generator interconnection requests as a Transmission Provider. Accordingly, the existing, planned and proposed generating plants at Pawnee and Missile Site stations were dispatched as noted below.

#### Pawnee local “generation pocket”

- ✓ Pawnee Fossil Fuel generation = 100% of rated capacity = 536 MW
- ✓ Manchief Gas generation = 90% of rated capacity = 252 MW
- ✓ Peetz Logan Wind generation = 40% of rated capacity = 230 MW

***Aggregate Generation Dispatched at Pawnee in all Cases = 1018 MW***

#### Missile Site local “generation pocket”

- ✓ Cedar Point (Missile Site 230kV) = 80% of rated capacity = 200 MW
- ✓ Limon I, II, III (Missile Site 345kV) = 80% of rated capacity = 480 MW
- ✓ GI-2016-3 (Missile Site 345kV) = 100% of rated capacity = 600 MW
- ✓ GI-2016-14 (Missile Site 345kV) = 100% of rated capacity = 500 MW

***Aggregate Generation Dispatched at Missile Site in Benchmark Case = 1280 MW***

***Aggregate Generation Dispatched at Missile Site in Study Case(s) = 1780 MW***

The GI-2016-14 *Benchmark Case* was derived from the 2021HS base case by changing the generation dispatch at Pawnee and Missile Site as noted above. The previously proposed GI-2016-3 generating plant was added at the Missile Site 345kV bus and dispatched at 600 MW rated output. Transmission facilities comprising the Pawnee – Daniels Park project modeled in the 2021HS case were retained in the Benchmark Case since they comprise the network upgrades identified for GI-2016-3.

The GI-2016-14 *Study Case* was created by adding the proposed GI-2016-14 generating plant in the Benchmark Case (which included GI-2016-3 generation) and



dispatching it at 500 MW rated output, thus resulting in 1100 MW aggregate injection at the Missile Site 345kV bus.

PSCo adheres to all applicable NERC Standards and WECC Criteria for Bulk Electric System (BES) acceptable performance, as well as its internal transmission planning criteria for all studies. During system intact (N-0) conditions, PSCo's steady-state performance criteria require the transmission bus voltages remain within 0.95 – 1.05 per unit of nominal and the power flows stay below the applicable normal ratings of the transmission facilities. Following a single contingency, the steady state bus voltages must remain within 0.90 – 1.05 per unit of nominal, and the power flows must continue to stay below the applicable normal facility ratings. For N-1 post-contingency system conditions, the applicable normal rating is the seasonal continuous rating of the transmission facility – but PSCo allows use of eight-hour facility rating for transformers for which it is available. Further, PSCo does not rely on 30-minute emergency ratings of transmission facilities for meeting N-1 system performance in planning studies.

As is evident from the power flow analysis results provided in Table A.1 in the Appendix (see page 11), the additional 500 MW generation injection into Missile Site Substation causes an overload of the Greenwood – Monaco 230 kV line following the loss of the Smoky Hill – Leetsdale 230 kV line. Therefore, a new network upgrade is required for the proposed GI-2016-14 interconnection to achieve 500 MW NRIS. The network upgrade scope is to replace limiting substation equipment to increase the thermal rating of the Greenwood – Monaco 230 kV line.

Consequently, this Feasibility Study concludes that the GI-2016-14 interconnection would achieve 500 MW NRIS (in addition to the 600 MW NRIS of GI-2016-3) provided the Pawnee – Daniels Park 345 kV project along with the identified Greenwood – Monaco 230 kV network upgrade are in-service.

Therefore, for GI-2016-14 interconnection:

NRIS (before network upgrades) = 0 MW

ERIS (before network upgrades) = 0 to 500 MW on “as-available” basis

NRIS and/or ERIS (after network upgrades) = 500 MW

### **Voltage Regulation and Reactive Power Capability**

Interconnection Customers are required to interconnect its Large Generating Facility with Public Service of Colorado's (PSCo) Transmission System in accordance with the *Xcel Energy Interconnection Guidelines for Transmission Interconnected Producer-Owned Generation Greater Than 20 MW* (available at: <http://www.transmission.xcelenergy.com/staticfiles/microsites/Transmission/Files/PDF/Interconnection/Interconnections-POL-TransmissionInterconnectionGuidelineGreat20MW.pdf>).

In addition, wind generating plant interconnections must also fulfill the performance requirements specified in FERC Order 661-A. Accordingly, the following voltage



regulation and reactive power capability requirements at the POI are applicable to this interconnection request:

- To ensure reliable operation, all Generating Facilities interconnected to the PSCo transmission system are expected to adhere to the Rocky Mountain Area Voltage Coordination Guidelines (RMAVCG). Accordingly, since the POI for this interconnection request is located within Northeast Colorado - Region 7 defined in the *RMAVCG*; the applicable ideal transmission system voltage profile range is 1.02 – 1.03 per unit at regulated buses and 1.0 – 1.03 per unit at non-regulated buses.
- Xcel Energy's OATT requires all Interconnection Customer Generation Facilities to have the reactive capability to achieve  $\pm 0.95$  power factor at the POI, with the maximum reactive capability (corresponding to rated output) available at all output levels. Furthermore, Xcel Energy requires all Generating Facilities to have dynamic voltage control capability and maintain the POI voltage specified by the Transmission Operator as long as the generating plant is on-line, producing power and it is not called upon to operate outside its 0.95 lag – 0.95 lead power factor range capability at the POI.
- It is the responsibility of the Interconnection Customer to determine the type (switched shunt capacitors and/or switched shunt reactors, etc.), the size (MVAR), and the locations (34.5 kV or 345 kV bus) of any additional static reactive power compensation needed within the generating plant in order to have adequate reactive capability to meet the  $\pm 0.95$  power factor and the 1.02 – 1.03 per unit voltage range standards at the POI. Further, for wind generating plants to meet the LVRT (Low Voltage Ride Through) performance requirements specified in FERC Order 661-A, an appropriately sized and located dynamic reactive power device (DVAR, SVC, etc.) may also need to be installed within the generating plant. Finally, it is the responsibility of the Interconnection Customer to compensate their generation tie-line to ensure minimal reactive power flow under no load conditions.
- The Interconnection Customer is required to demonstrate to the satisfaction of PSCo Transmission Operations prior to the commercial in-service date of the generating plant that it can safely and reliably operate within the required power factor and voltage ranges (noted above).

### **Short Circuit Analysis**

The short circuit study results show that no circuit breakers in the Missile Site Substation (or in PSCo's system) will be over-dutied by interconnecting the proposed GI-2016-14 wind generation facility. The base case scenario before GI-2016-14 included preliminary models for all expected transmission system improvements projected through the end of 2019 and also included preliminary modeling for the proposed GI-2016-3 project.



**GI-2016-14 Impact on Short Circuit Levels and Breaker Duty Margins at Missile Site 345 kV POI**

System Condition	Three-Phase (3-Ph) Fault Level (Amps)	Single-Line-to-Ground (SLG) Fault Level (Amps)	Thevenin System Equivalent Impedance (R + jX) (Ohms)
Before GI-2016-14 Y2019	17,000	16,020	Z1(pos)= 0.840 +j 11.686 Z2(neg)= 0.891 +j 11.681 Z0(zero)= 2.296 +j 13.714
After GI-2016-14 Y2019	17,569	16,354	Z1(pos)= 0.815 +j 11.308 Z2(neg)= 0.863 +j 11.303 Z0(zero)= 2.296 +j 13.711

**Costs Estimates and Assumptions**

GI-2016-14 (Feasibility Study Report)  
September 27, 2016

Indicative level cost estimates for Interconnection Facilities and Network/Infrastructure Upgrades for Delivery were developed by Public Service Company of Colorado (PSCo) / Xcel Energy (Xcel) Engineering. The cost estimates are in 2016 dollars with escalation and contingency factors included. AFUDC is not included. Estimates are developed assuming typical construction costs for previous completed projects. These estimates include all applicable labor and overheads associated with the siting support, engineering, design, material/equipment procurement, construction, testing and commissioning of these new substation and transmission line facilities. This estimate does not include the cost for any other Customer owned equipment and associated design and engineering.

**The estimated total cost for the required upgrades is \$14,057,000.**

Figure 2 below represents a conceptual one-line of the proposed interconnection into the Rush Creek-Missile Site 345kV Transmission Line. These estimates do not include costs for any other Customer owned equipment and associated design and engineering. The following tables list the improvements required to accommodate the interconnection and the delivery of the Project generation output. The cost responsibilities associated with these facilities shall be handled as per current FERC guidelines. Cost estimates and system improvements are subject to change upon a more detailed and refined design, which will occur in the system impact studies.

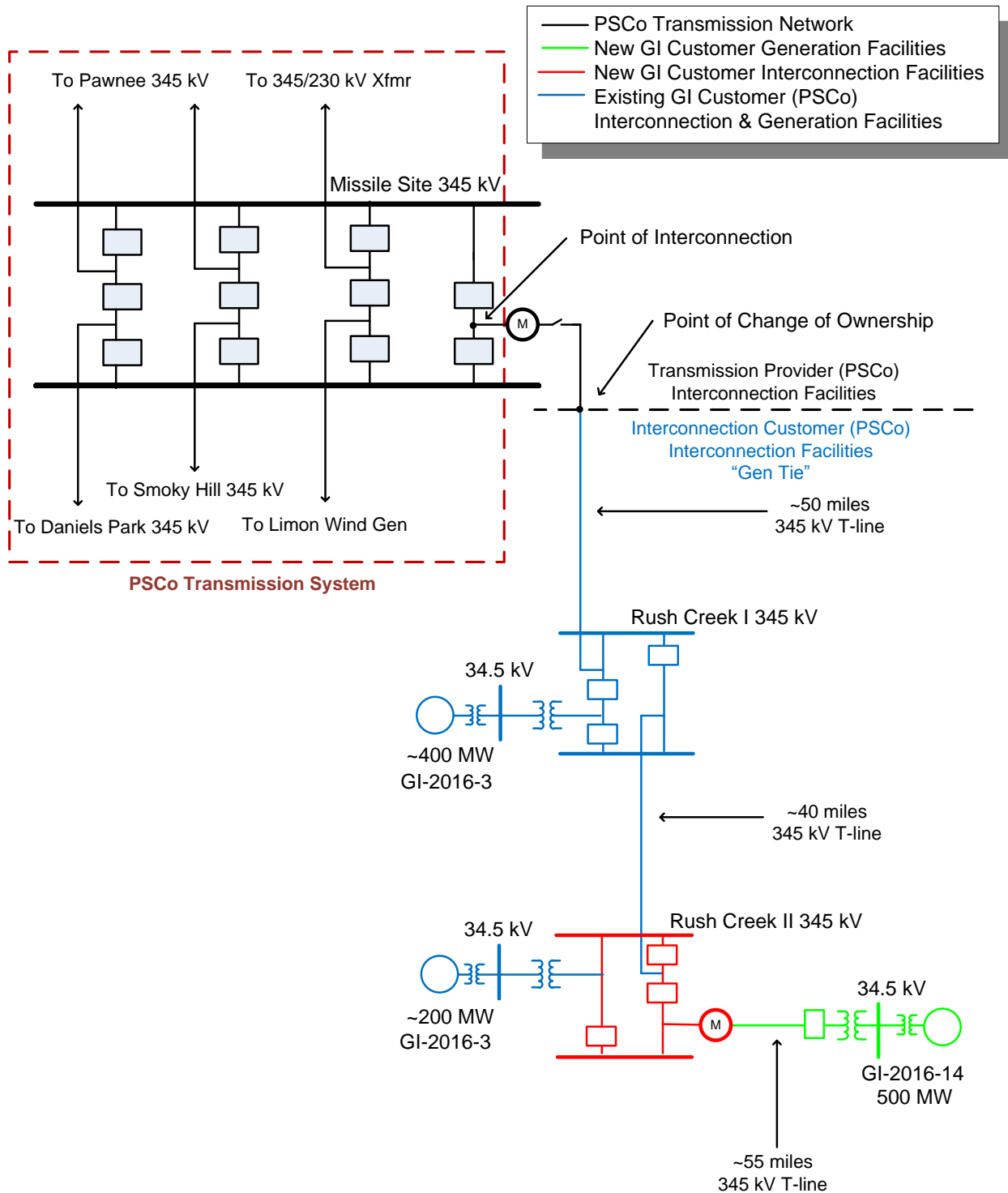

**Figure 2: GI-2016-14 Interconnection to 345 kV Bus in Missile Site Substation**



**Table 1 – PSCo Owned; Interconnection Customer Funded Interconnection Facilities**

Element	Description	Cost Estimate (Millions)
<b>PSCo's New Rush Creek II 345kV Station</b>	Three-position ring-bus 345kV station needed to interconnect the new Generating Facility to the planned Rush Creek-Missile Site (L7132) 345kV Transmission Line. The new equipment includes: <ul style="list-style-type: none"> <li>• Three 345kV circuit breakers</li> <li>• Six 345kV disconnect switches</li> <li>• Six 345kV CCVT's</li> <li>• Four 345kV line traps/tuner equipment</li> <li>• 345kV arresters</li> <li>• New Electric Equipment Enclosure (Control Bldg.)</li> <li>• New station battery system</li> <li>• Station controls</li> <li>• Associated communications, supervisory and SCADA equipment</li> <li>• Associated line relaying and testing</li> <li>• Associated bus, miscellaneous electrical equipment, cabling and wiring</li> <li>• Associated foundations and structures</li> <li>• Associated road and site development, fencing and grounding</li> </ul>	<b>\$12.030</b>
<b>Interconnection of Generating Facility's 345kV T-Line to New Rush Creek II Station</b>	Interconnect the last span of Transmission Line from new Generating Facility into the new 345 kV station. The new equipment includes: <ul style="list-style-type: none"> <li>• Two 345kV disconnect switches</li> <li>• 345kV arresters</li> <li>• One set (of 3) 345kV CT/PT metering units</li> <li>• Two 345kV line traps/tuner equipment</li> <li>• Station controls</li> <li>• Instrument transformers</li> <li>• Associated bus, wiring and equipment</li> <li>• Associated site development, grounding, foundations and structures</li> <li>• Associated transmission line communications, relaying and testing</li> </ul>	<b>\$1.665</b>
	Load Frequency/Automated Generation Control (LF/AGC) RTU and associated equipment.	<b>\$0.300</b>
	Siting and Land Rights support for siting studies, land and ROW acquisition and construction.	<b>\$0.040</b>
	<b>Total Cost Estimate for PSCo-Owned, PSCo-Funded Interconnection Facilities</b>	<b>\$14.035</b>
<b>Time Frame</b>	<b>Regulatory (CPCN), site, design, procure and construct</b>	<b>48 Months</b>

**Table 2 – PSCo Network Upgrades for Delivery**

Element	Description	Cost Est. (Millions)
<b>PSCo's Monaco 230kV Transmission Substation</b>	Upgrade/replace limiting substation equipment to achieve required MVA ratings on circuit 5281 Monaco-Greenwood OH/UG Line: <ul style="list-style-type: none"> <li>Six - 1272 dual jumpers</li> </ul>	<b>\$0.022</b>
	<b>Total Cost Estimate for PSCo Network Upgrades for Delivery Facilities</b>	<b>\$0.022</b>
<b>Time Frame</b>	<b>Design, procure and construct</b>	<b>18 months</b>

**Cost Estimate Assumptions:**

- Indicative level project cost estimates for Interconnection Facilities and Infrastructure Upgrades for Delivery, PSCo Funded Network Upgrades for Delivery (with no level of accuracy) were developed by PSCo Engineering
- Estimates are based on 2016 and similar type projects.
- AFUDC has been excluded.
- Labor is estimated for straight time only – no overtime included.
- Lead times for materials were considered for the schedule.
- The Generation Facility is not in the PSCo retail service territory. Therefore, no costs for retail load (distribution) facilities and metering required for station service are included in these estimates.
- Assuming the substation land acquisition (40 acres) planned for Xcel's project will be sufficient for this project substation expansion and build-out. No additional land required.
- Assuming a 3-breaker ring installation with required relaying, interconnection and communications facilities.
- PSCo (or our Contractor) crews will perform all construction, wiring, testing and commissioning for PSCo-owned and maintained facilities.
- Assuming a CPCN will be required. The estimated time frame for regulatory activities (CPCN) and to site, design, procure and construct the interconnection and network delivery facilities (entire Project) is approximately 48 months after authorization to proceed has been obtained.
- The Customer will be required to design, procure, install, own, operate and maintain a Load Frequency/Automated Generation Control (LF/AGC) RTU at their Customer Substation. PSCo / Xcel will need indications, readings and data from the LFAGC RTU.
- Customer will string OPGW fiber into substation as part of the transmission line construction scope.
- Breaker duty study determined that no breaker replacements are needed in neighboring substations.

## Appendix – Power Flow N-1 Contingency Analysis Results

### High Coincidence Generation Dispatch at Pawnee & Missile Site:

**Pawnee 230kV (100% Coal + 90% Gas + 40% Wind) = 1018 MW;**

**Missile Site 345kV Wind = 480 MW (80%); Missile Site 230kV Wind = 200 MW (80%)**

**600 MW output from GI-2016-3 is dispatched to sink at Blue Spruce, Rocky Mountain Energy Center, & Comanche**

**500 MW output from GI-2016-14 is dispatched to sink at Spindle, Rocky Mountain Energy Center & Comanche**

**Table A.1 – Differential Impact<sup>3</sup> of GI-2016-14 on Facility Loadings  
With Pawnee – Daniels Park 345kV Project In-Service**

				Branch N-1 Loading Before 500 MW GI (600 MW Total Injection)		Branch N-1 Loading After 500 MW GI (1100 MW Total Injection)			
Monitored Facility (Line or Transformer)	Type	Owner	Summer Normal (Continuous) Facility Rating in MVA	Flow in MVA	Flow in % of Summer Normal Rating	Flow in MVA	Flow in % of Summer Normal Rating	Differential Impact of GI-2016-14	N-1 Contingency Outage
Greenwood – Monaco 230 kV	Line	PSCo	404	404	100%	464.6	115%	15%	Smoky Hill -- Leetsdale 230 kV

<sup>3</sup> Due to proposed 500 MW generation increase at Missile Site 345 kV Substation