



Interconnection Feasibility Study Report Request # GI-2016-24

50 MW Solar Generating Facility
Interconnecting at
Green Valley 230 kV Substation, Colorado

Public Service Company of Colorado
Transmission Planning
April 4, 2017

Executive Summary

Public Service Company of Colorado (PSCo) received an Interconnection Request (IR) on October 3, 2016 which was assigned GI-2016-24 queue position. GI-2016-24 is a solar photovoltaic generating facility rated at 50 MW gross electrical output that will be located in Adams County, Colorado. The Point Of Interconnection (POI) requested for GI-2016-24 is the 230 kV bus within PSCo's Green Valley 230 kV Switching Station. As per the IR, GI-2016-24 is studied for both Network Resource Interconnection Service (NRIS) and Energy Resource Interconnection Service (ERIS).

The proposed 50 MW generating facility is expected to consist of approximately 25 inverters rated at 2.0 MW each. Preliminary information on the generating facility's layout suggests that the 25 inverters will be grouped in branches into three 34.5 kV collector systems, and each 34.5 kV collector system will connect to one 34.5/230 kV main step-up transformer. The generating facility will interconnect to the POI via an approximately 100 foot 230 kV transmission line.

The Commercial Operation Date (COD) requested for the generating facility is December 31, 2019. Based on the requested COD, the assumed back-feed date for the facility is June 30, 2019 (approximately six months before the COD).

Figure 1 below depicts the proposed POI for GI-2016-24 and the surrounding PSCo transmission system.

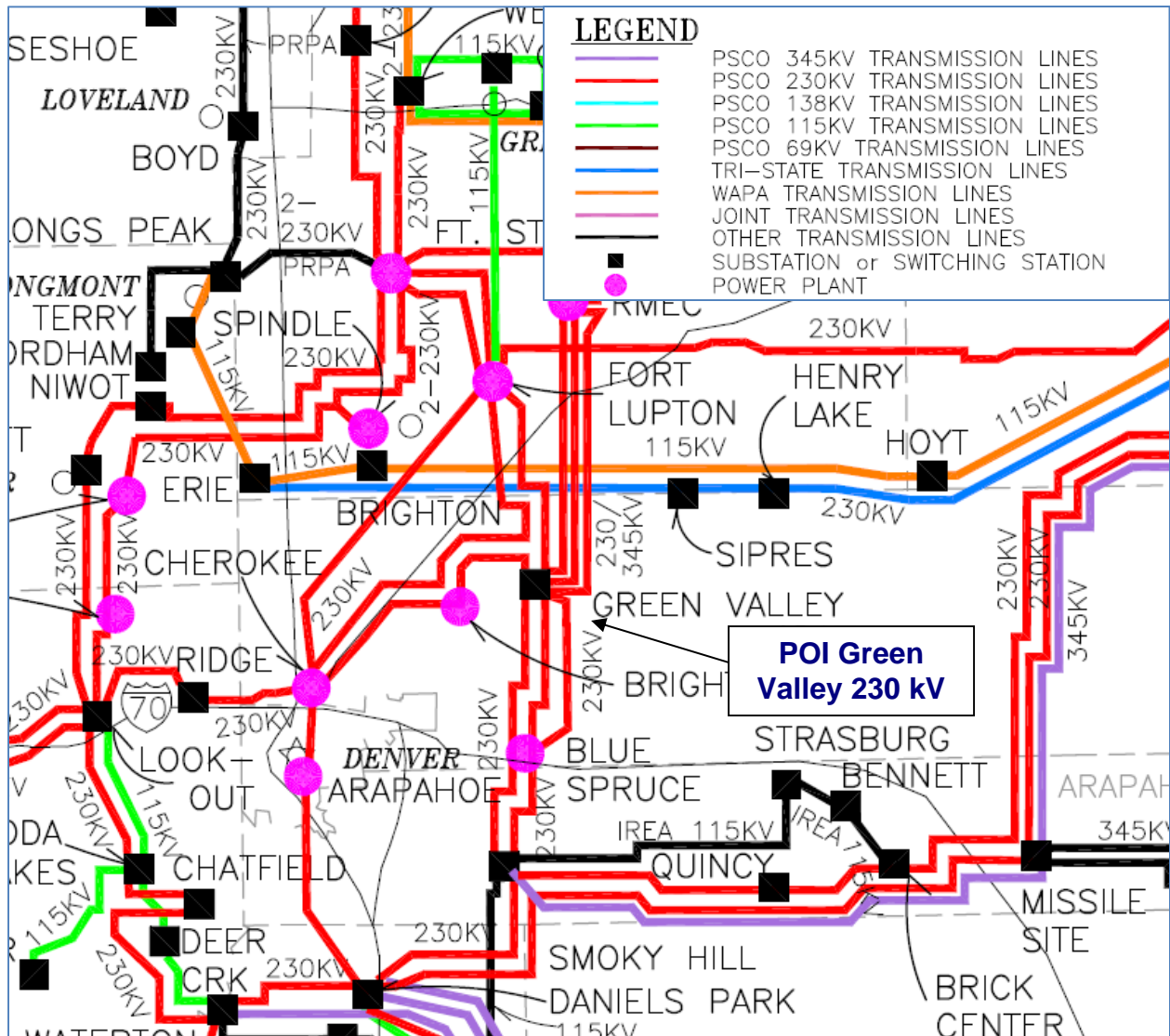

Figure 1: Green Valley Station and Surrounding Transmission System

The purpose of this Feasibility Study is to determine the feasibility of interconnecting the proposed GI-2016-24 at the Green Valley 230 kV POI. Towards this purpose, the study also identifies the transmission improvements needed to enable delivery of the 50 MW electrical output to PSCo network loads – that is, network upgrades needed for GI-2016-24 to qualify as NRIS.

The 50 MW electrical output of GI-2016-24 IR was studied as a stand-alone project. That is, the study did not include any prior-queued IR's existing in PSCo's or any affected party's Generation Interconnection queue except for those IR's which are:

- a) considered to be PSCo planned resources in recognition of their signed Power Purchase Agreements, or
- b) assumed in-service as per the agreed-upon study assumptions with the Interconnection Customer.



The Feasibility Study consisted of steady state (power flow) and short-circuit analyses. The power flow analyses were performed using two power flow models developed for GI-2016-24, both of which are based on the WECC 2021 heavy summer (2021HS) base case. The two power flow models are:

- Benchmark Case which models the planned 2021 transmission system prior to the GI-2016-24 interconnection (i.e. Before GI-2016-24 case).
- Study Case that also models the 50 MW output of the proposed GI-2016-24 interconnection (i.e. After GI-2016-24 case).

No affected parties are identified for GI-2016-24 since there were no adverse impacts to any other transmission owner's system.

Power flow analysis results provided in Table A.1 in the Appendix (see page 11) show that the additional 50 MW injection into Green Valley Station has no significant differential impact on the transmission system and, therefore, no network upgrades are required. Consequently this Feasibility Study concludes that the proposed GI-2016-24 interconnection qualifies for 50 MW ERIS and NRIS¹.

That is, for GI-2016-24 interconnection at Green Valley 230 kV POI with no network upgrades:

NRIS = 50 MW

ERIS = 50 MW

As shown in **Tables 1–3**, the total cost for the Interconnection Facilities and the Network Upgrades for Delivery is **\$3.54 million** and includes:

- \$1.09 million for PSCo-Owned, Interconnection Customer Funded Interconnection Facilities
- \$2.45 million for PSCo-Owned, PSCo Funded Interconnection Facilities

It is estimated that this work can be completed in approximately 18 months, following receipt of authorization to proceed.

Power Flow N-1 Contingency Analysis

The 2021HS base case was updated to dispatch the existing and planned generation within the Green Valley area at their respective highest coincident output deemed appropriate for the planning of adequate transmission capacity. This was done in accordance with the generation dispatch assumptions practiced by PSCo Transmission

¹ Network Resource Interconnection Service allows Interconnection Customer's Large Generating Facility to be designated as a Network Resource, up to the Large Generating Facility's full output, on the same basis as existing Network Resources interconnected to Transmission Provider's Transmission System, and to be studied as a Network Resource on the assumption that such a designation will occur. ([section 3.2.2 of Attachment N in Xcel Energy OATT](#))



Planning function to study the feasibility and system impact of generator interconnection requests as a Transmission Provider. Accordingly, the existing, planned and proposed generating plants near Green Valley Switching Station were dispatched as noted below.

- ✓ Rocky Mountain Energy Center gas generation = 586 MW
- ✓ Blue Spruce Energy Center gas generation = 268 MW
- ✓ Frank R. Knutson gas generation = 132 MW
- ✓ GI-2016-24 solar generation (Green Valley 230 kV) = 50 MW
- ✓

Aggregate Area Generation Dispatched in Benchmark Case = 986 MW

Aggregate Area Generation Dispatched in Study Case = 1,036 MW

The GI-2016-24 *Benchmark Case* was derived from the 2021HS base case by changing the aggregate generation dispatch near Green Valley Switching Station to 986 MW, as noted above. The GI-2016-24 *Study Case* was created by adding the proposed GI-2016-24 generating plant in the Benchmark Case and dispatching it at 50 MW rated output, thus resulting in 1,036 MW aggregate area generation near Green Valley Switching Station.

PSCo adheres to all applicable NERC Standards and WECC Criteria for Bulk Electric System (BES) acceptable performance, as well as its internal transmission planning criteria for all studies. During system intact (N-0) conditions, PSCo's steady-state performance criteria require the transmission bus voltages remain within 0.95 – 1.05 per unit of nominal and the power flows stay below the applicable normal ratings of the transmission facilities. Following a single contingency, the steady state bus voltages must remain within 0.90 – 1.05 per unit of nominal, and the power flows must continue to stay below the applicable normal facility ratings. For N-1 post-contingency system conditions, the applicable normal rating is the seasonal continuous rating of the transmission facility – but PSCo allows use of eight-hour facility rating for transformers for which it is available. Further, PSCo does not rely on 30-minute emergency ratings of transmission facilities for meeting N-1 system performance in planning studies.

As is evident from the power flow analysis results performed for this study, the additional 50 MW generation injection into Green Valley Switching Station causes no significant differential impact (greater than 2 percent power flow change) on the transmission system. Therefore, no network upgrade is required for the proposed GI-2016-24 interconnection to achieve 50 MW NRIS.

Consequently, this Feasibility Study concludes that the proposed GI-2016-24 interconnection qualifies for 50 MW ERIS and NRIS.

Therefore, for GI-2016-24 interconnection at Green Valley 230 kV POI with no network upgrades:

NRIS = 50 MW

ERIS = 50 MW

Voltage Regulation and Reactive Power Capability

Interconnection Customers are required to interconnect its Large Generating Facility with Public Service of Colorado's (PSCo) Transmission System in accordance with the *Xcel Energy Interconnection Guidelines for Transmission Interconnected Producer-Owned Generation Greater Than 20 MW* (available at: <http://www.transmission.xcelenergy.com/staticfiles/microsites/Transmission/Files/PDF/Interconnection/Interconnections-POL-TransmissionInterconnectionGuidelineGreat20MW.pdf>).

Accordingly, the following voltage regulation and reactive power capability requirements at the POI are applicable to this interconnection request:

- To ensure reliable operation, all Generating Facilities interconnected to the PSCo transmission system are expected to adhere to the *Rocky Mountain Area Voltage Coordination Guidelines (RMAVCG)*. Accordingly, since the POI for this interconnection request is located within Northeast Colorado - Region 7 defined in the *RMAVCG*; the applicable ideal transmission system voltage profile range is 1.02 – 1.03 per unit at regulated buses and 1.0 – 1.03 per unit at non-regulated buses.
- Xcel Energy's OATT (Attachment N effective 10/14/2016) requires all non-synchronous Generator Interconnection (GI) Customers to provide dynamic reactive power within the power factor range of 0.95 leading to 0.95 lagging at the high side of the generator substation. Furthermore, Xcel Energy requires every Generating Facility to have dynamic voltage control capability to assist in maintaining the POI voltage schedule specified by the Transmission Operator as long as the Generating Facility does not have to operate outside its 0.95 lag – 0.95 lead dynamic power factor range capability.
- It is the responsibility of the Interconnection Customer to determine the type (switched shunt capacitors and/or switched shunt reactors, etc.), the size (MVAR), and the locations (34.5 kV or 345 kV bus) of any additional static reactive power compensation needed within the generating plant in order to have adequate reactive capability to meet the +/- 0.95 power factor and the 1.02 – 1.03 per unit voltage range standards at the POI. Further, it is the responsibility of the Interconnection Customer to compensate their generation tie-line to ensure minimal reactive power flow under no load conditions.
- The Interconnection Customer is required to demonstrate to the satisfaction of PSCo Transmission Operations prior to the commercial in-service date of the generating plant that it can safely and reliably operate within the required power factor and voltage ranges (noted above).



Short Circuit Analysis

The short circuit study results show that no circuit breakers in the Green Valley Switching Station (or in PSCo's system) will be over-dutied by interconnecting the proposed GI-2016-24 solar generation facility. The base case scenario before GI-2016-24 included preliminary models for all expected transmission system improvements projected through the end of 2019. The GI-2016-24 Main Step-Up Transformer (MST) was assumed to be a two winding delta-wye transformer with 9 percent impedance on a 120 MVA base.

GI-2016-24 Impact on Short Circuit Levels and Breaker Duty Margins at Green Valley 230 kV POI

System Condition	Three-Phase (3-Ph) Fault Level (Amps)	Single-Line-to-Ground (SLG) Fault Level (Amps)	Thevenin System Equivalent Impedance (R + jX) (Ohms)
Before GI-2016-24 Y2019	31,609	21,893	Z1(pos)= 0.354 +j 4.186 Z2(neg)= 0.396 +j 4.179 Z0(zero)= 2.765 +j 9.489
After GI-2016-24 Y2019	31,809	22,945	Z1(pos)= 0.354 +j 4.186 Z2(neg)= 0.396 +j 4.179 Z0(zero)= 2.391 +j 8.828

Costs Estimates and Assumptions

PSCo Engineering has developed Indicative level (IE) cost estimates for Transmission Provider Interconnection Facilities and Network Upgrades required for the proposed GI-2016-24 Interconnection. The cost estimates are in 2017 dollars with escalation and contingency applied (AFUDC is not included). Indicative Estimates are based upon typical construction costs for previously performed similar construction projects; however they have no specified level of accuracy. These estimated costs include all applicable labor and overheads associated with the siting, engineering, design, and construction of these new PSCo facilities. These estimates do not include the costs for any Customer owned equipment and the associated design and engineering.

Figure 2 below represents a conceptual one-line diagram showing the proposed interconnection of GI-2016-24 generating facility in the Green Valley Switching Station.

As shown in **Tables 1-3**, the total cost for the Interconnection Facilities and the Network Upgrades for Delivery is **\$3.54 million**. The cost responsibilities associated with these facilities shall be handled as per current FERC guidelines. System improvements are subject to change upon a more detailed and refined design.

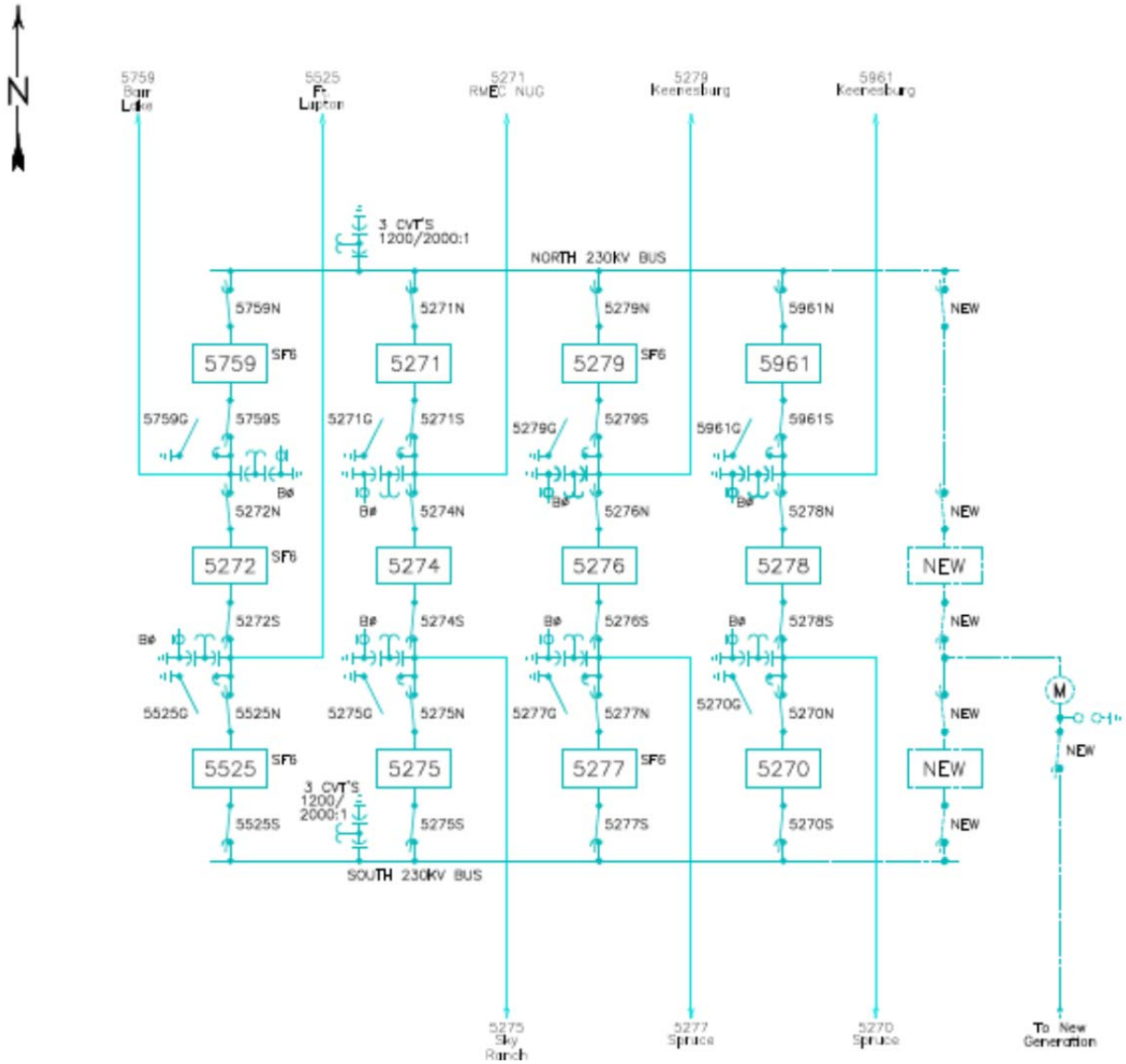

Figure 2: GI-2016-24 Interconnection to 230 kV Bus in Green Valley Station

Table 1 – PSCo Owned; Interconnection Customer Funded Interconnection Facilities

Element	Description	Cost Est. (Millions)
PSCo's Green Valley Transmission Substation	Interconnect Customer to the Green Valley 230kV Transmission Substation. The new equipment includes: <ul style="list-style-type: none"> • 230kV disconnect switch • 230kV arresters • 230kV CT/PT metering units • Station controls • Instrument transformers • Associated bus, wiring and equipment • Associated site development, grounding, foundations and structures • Associated transmission line communications, relaying and testing 	\$1.020
	230kV transmission line tap/upgrades into substation. Last span to substation on Customer line.	\$0.050
	Siting and Land Rights support for siting studies, land and ROW acquisition and construction.	\$0.020
	Total Cost Estimate for PSCo-Owned, Customer-Funded Interconnection Facilities	\$1.090
Time Frame	Site, design, procure and construct	18 Months

Table 2 – PSCo Owned: PSCo Funded Interconnection Facilities

Element	Description	Cost Estimate (Millions)
PSCo's Green Valley Transmission Substation	Interconnect Customer to the Green Valley 230kV Transmission Substation The new equipment includes: <ul style="list-style-type: none"> • Two 230kV circuit breaker • Five 230kV disconnect switches • Associated communications, supervisory and SCADA equipment • Associated line relaying and testing • Associated bus, miscellaneous electrical equipment, cabling and wiring • Associated foundations and structures • Associated road and site development, fencing and grounding 	\$2.400
	Siting and Land Rights support for siting studies, land and ROW acquisition and construction.	\$0.050
	Total Cost Estimate for PSCo-Owned, PSCo-Funded Interconnection Facilities	\$2.450
Time Frame	Site, design, procure and construct	18 Months

Table 3 – PSCo Network Upgrades for Delivery

Element	Description	Cost Est. (Millions)
	None identified at this point	N/A
	Total Cost Estimate for PSCo Network Upgrades for Delivery Facilities	\$0.000
Time Frame	Design, procure and construct	N/A

Cost Estimate Assumptions:

- Indicative level project cost estimates (IE's) for Interconnection Facilities were developed by PSCo Engineering. No level of accuracy is specified for IE's.
- Estimates are based on 2017 dollars (appropriate contingency and escalation included).
- AFUDC has been excluded.
- Labor is estimated for straight time only – no overtime included.
- Lead times for materials were considered for the schedule.



- The Customer's Generation Facility may not be located in PSCo's retail service territory. Therefore, no costs for retail load (distribution) facilities and metering required for station service are included in these estimates.
- No additional land is required.
- PSCo (or our Contractor) crews will perform all construction, wiring, testing and commissioning for PSCo owned and maintained facilities.
- A CPCN will not be required for the interconnection at the Green Valley Switching Station.
- The Customer will be required to design, procure, install, own, operate and maintain a Load Frequency/Automated Generation Control (LF/AGC) RTU at their Customer Substation. PSCo / Xcel will need indications, readings and data from the LFAGC RTU.
- Customer will string OPGW fiber into the substation as part of the transmission line construction scope.
- No breaker replacements are needed in neighboring substations.

Appendix – Power Flow N-1 Contingency Analysis Results

High Coincidence Generation Dispatch Near Green Valley:

Rocky Mountain Energy Center Gas 230kV = 586 MW;

Blue Spruce Energy Center Gas 230kV = 268 MW;

Frank R. Knutson Gas 230kV = 132 MW;

50 MW output from GI-2016-24 is dispatched to sink at Fort Lupton and Comanche

Table A.1 – Differential Impact² of GI-2016-24 on Facility Loadings

				Branch N-1 Loading Before 50 MW GI		Branch N-1 Loading After 50 MW GI			
Monitored Facility (Line or Transformer)	Type	Owner	Summer Normal (Continuous) Facility Rating in MVA	Flow in MVA	Flow in % of Summer Normal Rating	Flow in MVA	Flow in % of Summer Normal Rating	Differential Impact of GI-2016-24	N-1 Contingency Outage
Cherokee – California 115 kV	Line	PSCo	137	140	100.9%	140	101.8%	-0.1%	Cherokee – Mapleton 115 kV
Arapahoe – Englewood kV	Line	PSCo	120	139	116.8%	139	117.1%	0.3%	Waterton – Littleton 115 kV
Allison – Soda Lake 115 kV	Line	PSCo	152	157	101.6%	156	101.8%	0.2%	Bancroft – Gray Street 115 kV
Fort Lupton – Coors Rec 115 kV	Line	PSCo	120	134	114.0%	136	115.4%	1.4%	Valmont – Lafayette 115 kV

² Due to proposed 50 MW generation increase at Green Valley 230 kV Switching Station