



Interconnection Feasibility Study Report Request # GI-2016-25

Draft

500.25 MW Wind Generating Facility
Missile Site 345 kV Substation, Colorado

Public Service Company of Colorado
Transmission Planning
March 17, 2017

Executive Summary

Public Service Company of Colorado (PSCo) received an Interconnection Request (IR) on October 5, 2016 which was assigned GI-2016-25 queue position. GI-2016-25 is a wind generating facility rated at 500.25 MW gross electrical output that will be located in Kit Carson and Cheyenne County Colorado. The wind facility would connect to the transmission system at the end of the Missile Site – Rush Creek 345 kV line, which is also referred to as the Rush Creek II site. However, the point of interconnection (POI) for GI-2016-25 is the 345 kV bus within the Missile Site Substation, which is the point at which power from the wind facility is delivered to the PSCo system. As per the IR, GI-2016-25 is studied for both Network Resource Interconnection Service (NRIS) and Energy Resource Interconnection Service (ERIS).

The proposed 500.25 MW generating facility is expected to consist of approximately 145 wind turbine generators, where each turbine is rated 3.45 MW and is equipped with a 0.69/34.5 kV step-up transformer. Preliminary information on the wind generating facility's layout suggests that the 145 wind turbine generators will be grouped together into a 34.5 kV collector system, and the 34.5 kV collector system will connect to a 34.5/345 kV main step-up transformers (MST). The MST will connect to the Rush Creek II site via an approximately 25 mile 345 kV transmission line. The generating facility will ultimately interconnect to the Missile Site POI through the Rush Creek Gen-Tie, which is an 85 mile, 345 kV radial transmission line that is expected to be constructed by October 2018.

The Commercial Operation Date (COD) requested for the generating facility is October 31, 2020. Based on the requested COD, the assumed back-feed date for the facility is April 31, 2020 (approximately six months before the COD).

Figure 1 below depicts the proposed POI for GI-2016-25 and the surrounding PSCo transmission system.

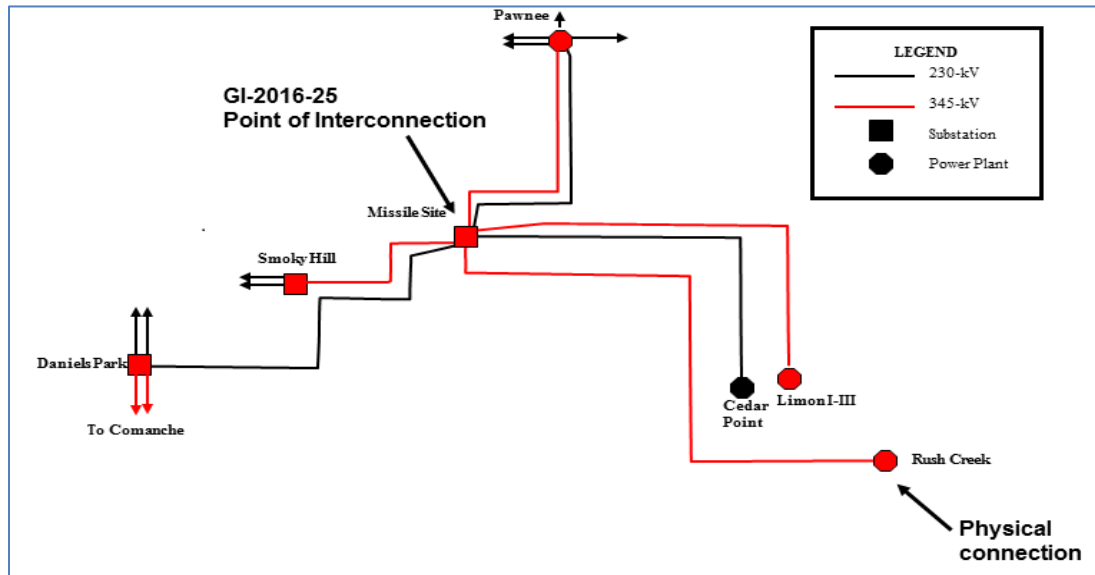

Figure 1: Missile Site and Surrounding Transmission System

The purpose of this Feasibility Study is to determine the feasibility of aggregate injection at the Missile Site 345 kV POI (for delivery to PSCo network loads) resulting from the proposed 500.25 MW output of GI-2016-25 in addition to the planned 600 MW output from GI-2016-3, which has the same POI, was assumed to be in service and in the models. Towards this purpose, the study also identifies the transmission improvements needed to enable delivery of the combined 1100.25 MW electrical output to PSCo network loads – that is, for GI-2016-25 to qualify as NRIS.

The 500.25 MW electrical output of GI-2016-25 IR was studied as a stand-alone project. That is, the study did not include any prior-queued IR's existing in PSCo's or any affected party's Generation Interconnection queue except those IR's which are:

- a) considered to be PSCo planned resources in recognition of their signed Power Purchase Agreements, or
- b) assumed in-service as per the agreed-upon study assumptions with the Interconnection Customer.

The Feasibility Study consisted of steady state (power flow) and short-circuit analyses. The power flow analyses were performed using two power flow models developed for GI-2016-25, both of which are based on the WECC 2021 heavy summer (2021HS) base case. The two power flow models are:

- a Benchmark Case which models the planned 2021 transmission system prior to the GI-2016-25 interconnection (Before GI-2016-25 case).
- a Study Case that includes the 500.25 MW generation under study (i.e. After GI-2016-25 case).



The Pawnee – Daniels Park 345 kV project¹ is a PSCo planned project for which the Colorado Public Utility Commission (CPUC) has approved a Certificate of Public Convenience and Necessity (CPCN) and has an in-service date of October 31, 2019. Studies for GI-2016-3 demonstrated that the Pawnee – Daniels Park project was needed to deliver the 600 MW to the PSCo system. Therefore, that project was included in the power flow models.

The studies indicated that there were no adverse impacts to other systems. However, Tri-State Generation and Transmission Association (Tri-State) has requested to be included as an “affected party”, for interconnections at or near the Rush Creek project, due to the proximity of their transmission system. Therefore, Tri-State is an affected party for GI-2016-25.

This Feasibility Study showed that the additional 500.25 MW generation injection into Missile Site Substation has the potential to overload the Greenwood – Monaco 230 kV line following the loss of the Smoky Hill – Leetsdale 230 kV line. Results are shown in the power flow analysis results provided in Table A.1 in the Appendix (see page 11). Therefore, a new network upgrade is required for the proposed GI-2016-25 interconnection to achieve 500.25 MW NRIS². The network upgrade consists of replacing limiting substation equipment to increase the thermal rating of the Greenwood – Monaco 230 kV line.

Consequently this Feasibility Study concludes that the GI-2016-25 interconnection qualifies for 500.25 MW NRIS and ERIS (in addition to the 600 MW NRIS of GI-2016-3) provided the Pawnee – Daniels Park 345 kV project is in service, and the identified Greenwood – Monaco 230 kV network upgrades are in service.

Therefore, for GI-2016-25 interconnection:

NRIS (before network upgrades) = 0 MW

ERIS (before network upgrades) = 0 to 500.25 MW on “as-available” basis

NRIS and/or ERIS (after network upgrades) = 500.25 MW

As shown in **Tables 1–2**, the cost for the Interconnection Facilities and the Network Upgrades for Delivery is **\$13.732 million** and includes:

- \$13.71 million for PSCo-Owned, Interconnection Customer Funded Interconnection Facilities
- \$0.022 million for PSCo Network Upgrades for Delivery to PSCo Loads

It is estimated that this work can be completed in approximately 36 months, following receipt of authorization to proceed. The schedule assumes a Certificate of Public

¹ More information at: <http://www.transmission.xcelenergy.com/Projects/Colorado>

² Network Resource Interconnection Service allows Interconnection Customer 's Large Generating Facility to be designated as a Network Resource, up to the Large Generating Facility's full output, on the same basis as existing Network Resources interconnected to Transmission Provider's Transmission System, and to be studied as a Network Resource on the assumption that such a designation will occur. (*section 3.2.2 of Attachment N in Xcel Energy OATT*)



Convenience and Necessity (CPCN) for the 345 kV substation at the Rush Creek II site would be required.

Power Flow N-1 Contingency Analysis

The 2021HS base case was updated to dispatch the existing and planned generation within the Pawnee and Missile Site “generation pockets” (i.e. aggregate of generation in the local area) at their respective highest coincident output deemed appropriate for the planning of adequate transmission capacity. This was done in accordance with the generation dispatch assumptions practiced by PSCo Transmission Planning function to study the feasibility and system impact of generator interconnection requests as a Transmission Provider. Accordingly, the existing, planned and proposed generating plants at Pawnee and Missile Site stations were dispatched as noted below.

Pawnee local “generation pocket”

- ✓ Pawnee Fossil Fuel generation = 100% of rated capacity = 536 MW
- ✓ Manchief Gas generation = 90% of rated capacity = 252 MW
- ✓ Peetz Logan Wind generation = 40% of rated capacity = 230 MW

Aggregate Generation Dispatched at Pawnee in all Cases = 1018 MW

Missile Site local “generation pocket”

- ✓ Cedar Point (Missile Site 230kV) = 80% of rated capacity = 200 MW
- ✓ Limon I, II, III (Missile Site 345kV) = 80% of rated capacity = 480 MW
- ✓ GI-2016-3 (Missile Site 345kV) = 100% of rated capacity = 600 MW
- ✓ GI-2016-25 (Missile Site 345kV) = 100% of rated capacity = 500.25 MW

Aggregate Generation Dispatched at Missile Site in Benchmark Case = 1280 MW

Aggregate Generation Dispatched at Missile Site in Study Case(s) = 1780.25 MW

The GI-2016-25 *Benchmark Case* was derived from the 2021HS base case by changing the aggregate area generation dispatch at Pawnee and Missile Site to 1280 MW as noted above. The previously proposed GI-2016-3 generating plant was added at the Missile Site 345kV bus and dispatched at 600 MW rated output. Transmission facilities comprising the Pawnee –Daniels Park project modeled in the 2021HS case were retained in the Benchmark Case since they comprise the network upgrades identified for GI-2016-3.

The GI-2016-25 *Study Case* was created by adding the proposed GI-2016-25 generating plant in the Benchmark Case (which included GI-2016-3 generation) and dispatching it at 500.25 MW rated output, thus resulting in 1100.25 MW aggregate injection at the Missile Site 345kV bus.



PSCo adheres to all applicable NERC Standards and WECC Criteria for Bulk Electric System (BES) acceptable performance, as well as its internal transmission planning criteria for all studies. During system intact (N-0) conditions, PSCo's steady-state performance criteria require the transmission bus voltages remain within 0.95 – 1.05 per unit of nominal and the power flows stay below the applicable normal ratings of the transmission facilities. Following a single contingency, the steady state bus voltages must remain within 0.90 – 1.05 per unit of nominal, and the power flows must continue to stay below the applicable normal facility ratings. For N-1 post-contingency system conditions, the applicable normal rating is the seasonal continuous rating of the transmission facility – but PSCo allows use of eight-hour facility rating for transformers for which it is available. Further, PSCo does not rely on 30-minute emergency ratings of transmission facilities for meeting N-1 system performance in planning studies.

As is evident from the power flow analysis results provided in Table A.1 in the Appendix (see page 11), the additional 500.25 MW generation injection into Missile Site Substation causes an overload of the Greenwood – Monaco 230 kV line following the loss of the Smoky Hill – Leetsdale 230 kV line. Therefore, a new network upgrade is required for the proposed GI-2016-25 interconnection to achieve 500.25 MW NRIS. The network upgrade scope is to replace limiting substation equipment to increase the thermal rating of the Greenwood – Monaco 230 kV line.

Consequently, this Feasibility Study concludes that the GI-2016-25 interconnection qualifies for 500.25 MW NRIS and ERIS (in addition to the 600 MW NRIS of GI-2016-3) provided the Pawnee – Daniels Park 345 kV project along with the identified Greenwood – Monaco 230 kV network upgrade are in-service.

Therefore, for GI-2016-25 interconnection:

NRIS (before network upgrades) = 0 MW

ERIS (before network upgrades) = 0 to 500.25 MW on “as-available” basis

NRIS and/or ERIS (after network upgrades) = 500.25 MW

Voltage Regulation and Reactive Power Capability

Interconnection Customers are required to interconnect its Large Generating Facility with Public Service of Colorado's (PSCo) Transmission System in accordance with the *Xcel Energy Interconnection Guidelines for Transmission Interconnected Producer-Owned Generation Greater Than 20 MW* (available at:

<http://www.transmission.xcelenergy.com/staticfiles/microsites/Transmission/Files/PDF/Interconnection/Interconnections-POL-TransmissionInterconnectionGuidelineGreat20MW.pdf>).

In addition, wind generating plant interconnections must also fulfill the performance requirements specified in FERC Order 661-A. Accordingly, the following voltage regulation and reactive power capability requirements at the POI are applicable to this interconnection request:

- To ensure reliable operation, all Generating Facilities interconnected to the PSCo transmission system are expected to adhere to the Rocky Mountain Area Voltage Coordination Guidelines (RMAVCG). Accordingly, since the POI for this interconnection request is located within Northeast Colorado - Region 7 defined in the *RMAVCG*; the applicable ideal transmission system voltage profile range is 1.02 – 1.03 per unit at regulated buses and 1.0 – 1.03 per unit at non-regulated buses.
- Xcel Energy's OATT (Attachment N effective 10/14/2016) requires all Generator Interconnection (GI) Customers to provide dynamic reactive power within the power factor range of 0.95 leading to 0.95 lagging at the high side of the generator substation. Accordingly, for GI-2016-25, the 0.95 lag – 0.95 lead dynamic reactive power is measured at the metered interface between the Generating Facility and the Interconnection Facilities of the GI Customer – that is, at the metering location shown in the conceptual one-line in Figure 2. Furthermore, Xcel Energy requires every Generating Facility to have dynamic voltage control capability to assist in maintaining the POI voltage schedule specified by the Transmission Operator as long as the Generating Facility does not have to operate outside its 0.95 lag – 0.95 lead dynamic power factor range capability.
- It is the responsibility of the Interconnection Customer to determine the type (switched shunt capacitors and/or switched shunt reactors, etc.), the size (MVAR), and the locations (34.5 kV or 345 kV bus) of any additional static reactive power compensation needed within the generating plant in order to have adequate reactive capability to meet the +/- 0.95 power factor and the 1.02 – 1.03 per unit voltage range standards at the POI. Further, for wind generating plants to meet the LVRT (Low Voltage Ride Through) performance requirements specified in FERC Order 661-A, an appropriately sized and located dynamic reactive power device (DVAR, SVC, etc.) may also need to be installed within the generating plant. Finally, it is the responsibility of the Interconnection Customer to compensate their generation tie-line to ensure minimal reactive power flow under no load conditions.
- The Interconnection Customer is required to demonstrate to the satisfaction of PSCo Transmission Operations prior to the commercial in-service date of the generating plant that it can safely and reliably operate within the required power factor and voltage ranges (noted above).

Short Circuit Analysis

The short circuit analysis was not available at the time of the draft Feasibility Study report posting. The study will be amended as soon as the short circuit data becomes available. However, the prior GI-2016-14 feasibility study found no over-dutied circuit breakers due to a 500 MW injection at Missile Site 345 kV switchyard and therefore it can be assumed no over-dutied circuit breakers would be found for the proposed GI-2016-25.



GI-2016-25 Impact on Short Circuit Levels and Breaker Duty Margins at Missile Site 345 kV POI

System Condition	Three-Phase (3-Ph) Fault Level (Amps)	Single-Line-to-Ground (SLG) Fault Level (Amps)	Thevenin System Equivalent Impedance (R + jX) (Ohms)

Costs Estimates and Assumptions

PSCo Engineering has developed an Indicative Estimate (IE) for Transmission Provider Interconnection Facilities and Network Upgrades required for the proposed GI-2016-25 Interconnection. The cost estimates are in 2016 dollars with escalation and contingency applied (AFUDC is not included). Indicative Estimates are based upon typical construction costs for previously performed similar construction projects; however they have no specified level of accuracy. These estimated costs include all applicable labor and overheads associated with the siting support, engineering, design, and construction of these new PSCo facilities. The estimates do not include the costs for any Customer owned equipment and associated design and engineering.

Figure 2 below represents a conceptual one-line of the proposed interconnection of GI-2016-25 generating facility in the Missile Site 345kV bus.

As shown in **Tables 1-2**, the total cost for the Interconnection Facilities and Network Upgrades for Delivery is **\$13.732 million**. The cost responsibilities associated with these facilities shall be handled as per current FERC guidelines. System improvements are subject to change upon a more detailed and refined design.

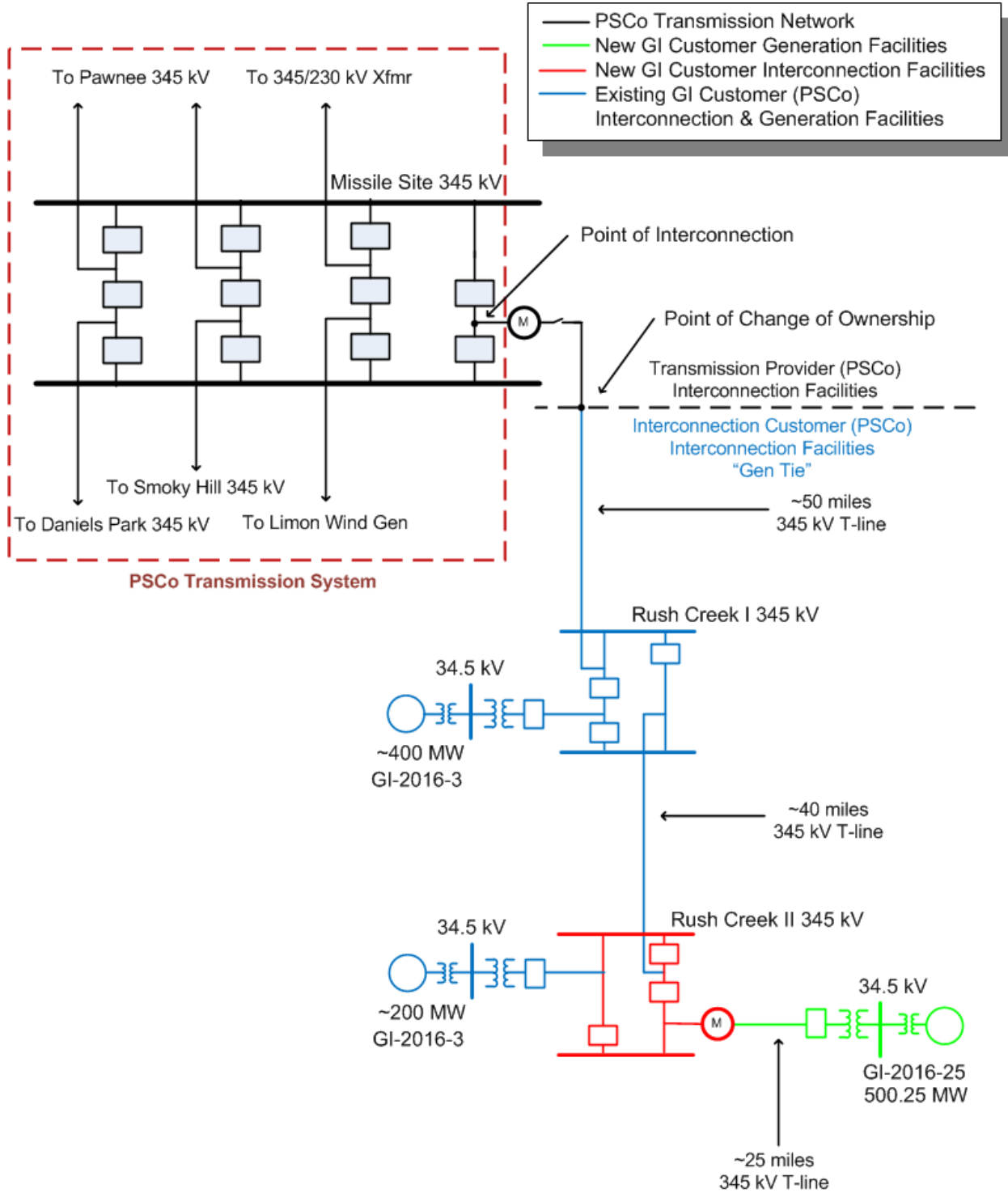

Figure 2: GI-2016-25 Interconnection to 345 kV Bus in Missile Site Substation

Table 1 – PSCo Owned; Interconnection Customer Funded Interconnection Facilities

Element	Description	Cost Estimate (Millions)
PSCo's New Rush Creek II 345kV Station	Interconnect Customer to tap the proposed/planned Rush Creek-Missile Site 345kV Transmission Line. The new equipment includes: <ul style="list-style-type: none"> • Three 345kV circuit breakers • Six 345kV disconnect switches • Six 345kV CCVT's • Four 345kV line traps/tuner equipment • 345kV arresters • New Electric Equipment Enclosure (Control Bldg.) • New station battery system • Station controls • Associated communications, supervisory and SCADA equipment • Associated line relaying and testing • Associated bus, miscellaneous electrical equipment, cabling and wiring • Associated foundations and structures • Associated road and site development, fencing and grounding 	\$11.800
Interconnection of Generating Facility's 345kV T-Line to New Rush Creek II Station	Interconnect Customer to tap the proposed 345kV Transmission Substation. The new equipment includes: <ul style="list-style-type: none"> • Two 345kV disconnect switches • 345kV arresters • One set (of 3) 345kV CT/PT metering units • Two 345kV line traps/tuner equipment • Station controls • Instrument transformers • Associated bus, wiring and equipment • Associated site development, grounding, foundations and structures • Associated transmission line communications, relaying and testing • 345kV transmission tap into substation. Last span into substation on Customer line. 	\$1.870
	Siting and Land Rights support for siting studies, land and ROW acquisition and construction.	\$0.040
	Total Cost Estimate for PSCo-Owned, PSCo-Funded Interconnection Facilities	\$13.710
Time Frame	Regulatory (CPCN), site, design, procure and construct	36 Months

Table 2 – PSCo Network Upgrades for Delivery

Element	Description	Cost Est. (Millions)
PSCo's Monaco 230kV Transmission Substation	Upgrade/replace limiting substation equipment to achieve required MVA ratings on circuit 5281 Monaco-Greenwood OH/UG Line: <ul style="list-style-type: none"> • Six - 1272 dual jumpers 	\$0.022
	Total Cost Estimate for PSCo Network Upgrades for Delivery Facilities	\$0.022
Time Frame	Design, procure and construct	18 months

Cost Estimate Assumptions:

- Indicative level project cost estimates (IE) for Interconnection Facilities were developed by PSCo Engineering. No level of accuracy is specified for IE's.
- AFUDC has been excluded.
- Labor is estimated for straight time only – no overtime included.
- Lead times for materials were considered for the schedule.
- The Customer's Generation Facility is not in PSCo's retail service territory. Therefore, no costs for retail load (distribution) facilities and metering required for station service are included in these estimates. .
- Assuming the substation land acquisition (40 acres) planned for Xcel's project will be sufficient for this project substation expansion and build-out. No additional land required.
- Assuming a 3-breaker ring installation with required relaying, interconnection and communications facilities.
- PSCo (or our Contractor) crews will perform all construction, wiring, testing and commissioning for PSCo owned and maintained facilities.
- Assuming a CPCN will be required. The estimated time frame for regulatory activities (CPCN) and to site, design, procure and construct the interconnection and network delivery facilities (entire Project) is approximately 36 months after authorization to proceed has been obtained.
- The Customer shall design, procure, install, own, operate and maintain a Load Frequency/Automated Generation Control (LF/AGC) RTU at their Customer Substation. PSCo / Xcel will need indications, readings and data from the LFAGC RTU.
- Customer shall string OPGW fiber into Rush Creek II substation as part of the transmission line construction scope.
- No breaker replacements are needed in neighboring substations.

Appendix – Power Flow N-1 Contingency Analysis Results

High Coincidence Generation Dispatch at Pawnee & Missile Site:

Pawnee 230kV (100% Coal + 90% Gas + 40% Wind) = 1018 MW;

Missile Site 345kV Wind = 480 MW (80%); Missile Site 230kV Wind = 200 MW (80%)

600 MW output from GI-2016-3 is dispatched to sink at Blue Spruce, Rocky Mountain Energy Center, & Comanche

500.25 MW output from GI-2016-25 is dispatched to sink at Spindle, Rocky Mountain Energy Center & Comanche

**Table A.1 – Differential Impact³ of GI-2016-25 on Facility Loadings
With Pawnee – Daniels Park 345kV Project In-Service**

				Branch N-1 Loading Before 500.25 MW GI (600 MW Total Injection)		Branch N-1 Loading After 500.25 MW GI (1100 MW Total Injection)			
Monitored Facility (Line or Transformer)	Type	Owner	Summer Normal (Continuous) Facility Rating in MVA	Flow in MVA	Flow in % of Summer Normal Rating	Flow in MVA	Flow in % of Summer Normal Rating	Differential Impact of GI-2016-25	N-1 Contingency Outage
Greenwood – Monaco 230 kV	Line	PSCo	404	404	100%	464.6	115%	15%	Smoky Hill -- Leetsdale 230 kV

³ Due to proposed 500.25 MW generation increase at Missile Site 345 kV Substation